



CHP  
TECHNICAL ASSISTANCE  
PARTNERSHIPS

# National Aeronautics and Space Administration (NASA) Lyndon B. Johnson Space Center 12 MW CHP Plant

*Natural Gas-Powered CHP system providing power to majority of site.*



## Site Description

NASA's Lyndon B. Johnson Space Center (JSC) has served as a hub of human spaceflight activity for more than sixty years. JSC is home to the nation's astronaut corps, the International Space Station mission operations, the Orion Program and a host of future space developments. Approximately 7,000 employees occupy the facility, nestled on almost 1,700 acres near Houston.

Funding for The Johnson Space Center (JSC) combined heat and power (CHP) plant was provided through the DOE's Energy Savings Performance Contracting (ESPC) partnership with Energy Systems Group, an energy service provider. This is a budget-neutral approach to make building improvements that reduce energy and water usage while increasing operational efficiency. The bulk of the project costs, including installation, operation and maintenance, were borrowed through the energy services company and paid for with savings. In this project, utility budget savings are used to fund the ESPC. Since O&M for new equipment is included, there will be no increase to the current Facilities contract. The ESPC also provides that all ESCO installed equipment have at least 10 years of remaining operational life at the end of the contract term of twenty-two years.

## Quick Facts

**LOCATION:** Houston, Texas  
**MARKET SECTOR:** Government  
**ENERGY OUTPUT:** 11.9 MW  
**FUEL:** Natural Gas  
**EQUIPMENT:** Combustion Turbine and Steam Turbine  
**THERMAL ENERGY USE:** Heating and Cooling  
**IN OPERATION SINCE:** 2017  
**TOTAL PROJECT COST:** ~\$47 million  
**EXPECTED SAVINGS:** ~\$141 million over 22 years  
**ENVIRONMENTAL BENEFITS:** CHP system reduced energy intensity from 212,716 BTU/GSF to 103,616 BTU/GSF.

## CHP Equipment and Configuration

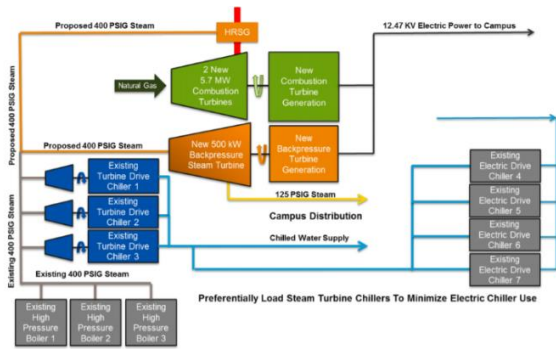

JSC's CHP plant, operating in parallel with the utility, will power approximately 70% of the site base electric load. The waste heat from generators is converted into steam. This provides 100% site steam load, and between 40 and 60 percent peak chilled water load. This is possible because of the existing steam turbine chillers in the JSC plant. Further, in the event of utility power disruptions, the CHP plant provides the potential for island microgrid operation of critical mission operations such as the Orion program and International Space Station (ISS) Mission Control.

The CHP plant produces nearly 12 MW of electricity via two 5.7 MW combustion turbines and one 500 kW steam turbine. Utilizing waste heat from the combustion turbines, the two heat recovery steam generators produce ~50,000 lbs./hour of high pressure steam. This steam is simultaneously used for heating as well as to generate chilled water through existing steam turbine-driven chillers. Whereas traditional utility power provides 35-45% efficiency, ESG claims that NASA JSC's CHP plant allows for approximately 85% efficient operations. *This CHP system allows JSC to meet federally mandated energy reduction metrics.*

## Lessons Learned

DOE alternative financing projects are quite different from typical construction projects. The U.S. Department of Energy provides excellent off-site, on-site, computer based and webinar format training specific to these programs. As well as training, Project Facilitators (PF) can provide objective advice to assist with project implementation. With dedicated, deep experience, facilitators are crucial to avoiding costly missteps and ensuring full value for the taxpayers' money. For more information, see: <https://www.energy.gov/eere/femp/project-facilitators-federal-esc-uesc-and-esc-enable-projects>

As a project begins, keep in mind:

- Include a wide range of specialties such as procurement, environmental, legal, utilities and even historic preservation where applicable.
- Start early planning and involvement with the utilities are a must to avoid potential project crippling issues with energy supply, connection to local grids and cost.
- Consider hiring specialist consultants.
- Plan for legal, procurement and regulatory issues. These areas tend to take a substantial amount of time so allowing for plenty of time in the schedule for preparation of documents, reviews and responding to review comments and inquires is highly recommended.

In summary, be prepared for a complex and challenging project requiring great commitment, full management support, a knowledgeable team, careful planning, flexibility and extensive coordination. The cost and energy savings of this project makes it all worth it.

*'Reductions in energy usage, emissions and improvements in reliability and security made this project the right choice for JSC.'*

## For More Information

U.S. DOE SOUTHCENTRAL CHP  
TECHNICAL ASSISTANCE  
PARTNERSHIP (CHP TAP)  
Gavin Dillingham, PhD, Director  
281.216.7147  
[gdillingham@harcresearch.org](mailto:gdillingham@harcresearch.org)

NASA – Johnson Space Center  
<https://spacecenter.org/>

More CHP Project Profiles:  
[www.CHPTAP.org](http://www.CHPTAP.org)

Date produced: April 2019