



Founded in 1946

Project: \_\_\_\_\_

Items: \_\_\_\_\_

Quantity: \_\_\_\_\_

Approval: \_\_\_\_\_

Date: \_\_\_\_\_

ON-LINE ORDER PICKING WORK STATION

## On-Line Order Picking Work Station

Multi-Faceted Order Picking Cart, loaded with features, an all-in-one work station. Streamlines the picking process and increases production.

### Features:

- Constructed of all welded aluminum
- Powder coated red. Other colors available upon request.
- Includes printer basket, utility shelf, bag holder, label roll rod, paper towel rod, and water holder.
- Holds 6 lugs for order picking: approximately 22" L x 15.25" W x 10" H (not included).
- Weight Capacity: 40 lbs per tote

### Benefits:

- Solid top offers additional working area.
- Vinyl grip handles assist in maneuvering the cart with ergonomic design.
- Light weight
- Easily maneuvered



ALTPC-2536-MO



Winholt Equipment | 20 Crossways Park North, Suite 205 | Woodbury, New York 11797

Pennsylvania | Texas | California

800.444.3595 | sales@winholt.com | www.winholt.com



# On-Line Order Picking Work Station

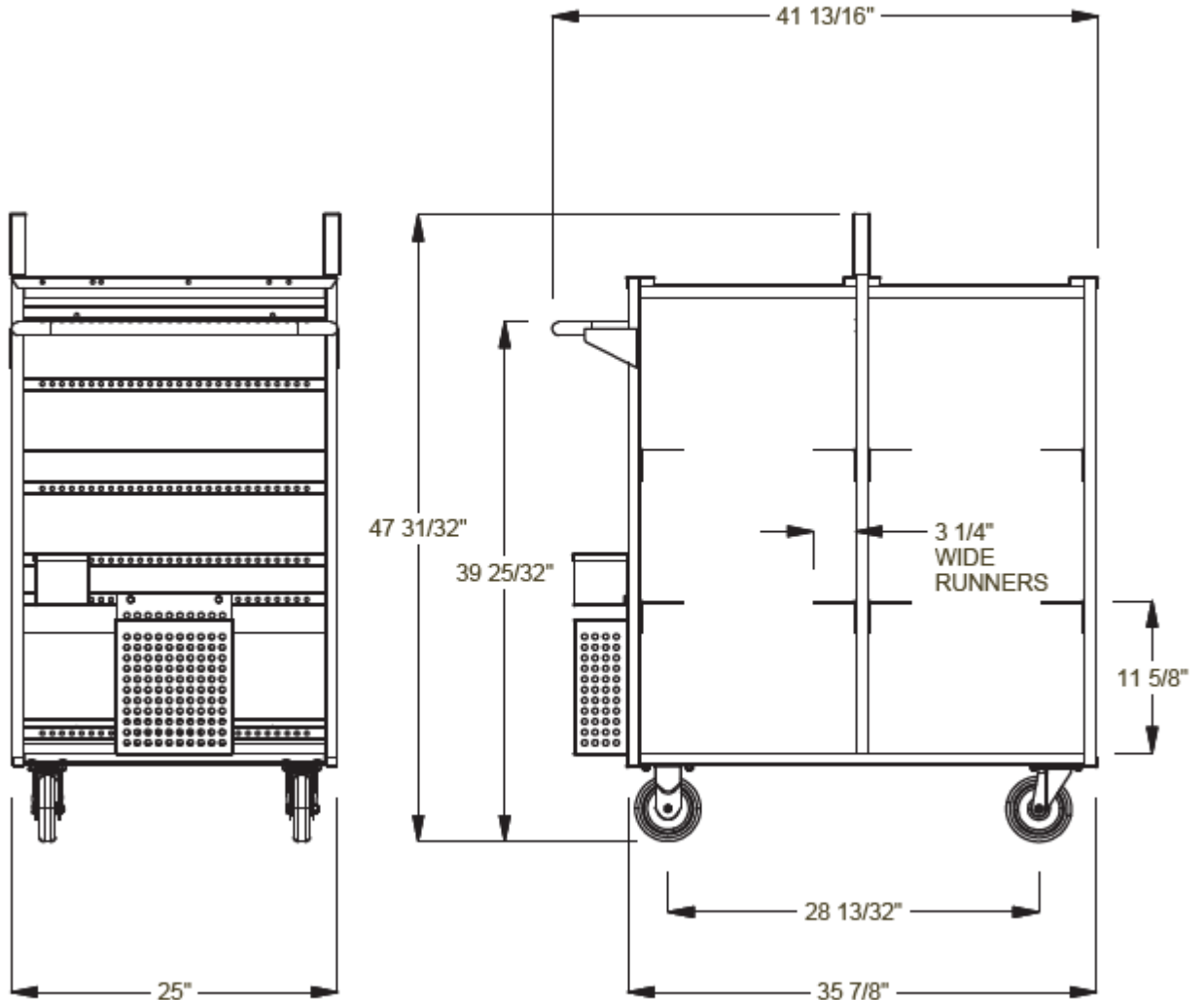

Model Number	Order#	Overall Dimensions						Approx. Ship Wt	
		Width		Length		Height		(lb)	(kg)
		(in)	(mm)	(in)	(mm)	(in)	(mm)		
ALTPC-2536-MO	1141967	25	635	42.75	1086	47.9	1216	52	24

**Caster Information:**

Swivel Plate Caster with 5" Polyurethane Wheel & Brake 738AW/LC

Rigid Plate Caster with 5" Polyurethane Wheel 743W

5" Polyurethane Wheel 7112

**Freight Class: 250**



In line with our policy to continually improve our products, Winholt reserves the right to change materials and specifications without notice.