

**ORDER DEADLINE:  
APRIL 15TH, 2026**



- AN ICONIC ELECTRIC MOTOR IN PLASTIC FOR THE FIRST TIME!
- OPERATING FAIVELEY PANTOGRAPHS AND ROTATING BEARING CAPS
- FOUR GREAT ROADNAMES AND DETAIL VARIATIONS TO PICK FROM

The Pennsylvania Railroad was well known for their usage of electrified freight railroading. They took advantage of their main lines being electrified for passenger use from Washington to Harrisburg and even to New York. In fact, it was predicted that the future of rail would rely on electrifying future routes for this type of service. In the 1960s, the Pennsylvania Railroad needed a new electric motor to replace their aging P5a motors, which had been in service since the 1930s. The PRR settled on GE's E44 motor. The E44 was able to output 4,400 horsepower in a boxy shape, which ultimately helped gain its nickname of "brick". Sixty class E44 electric motors were built by GE, with a ignitron rectifier system. Six more were built using the new silicon diode rectifier systems GE instituted. These were classified as E44a motors and rated at 5,500 horsepower. During the Penn-Central era, 22 E44 motors were upgraded to E44a specifications. However, when Penn-Central became embroiled in their bankruptcy woes, the program was halted.

**THE RAPIDO E44 ELECTRIC MOTOR FEATURES:**

- Accurately scaled from the prototype
- Operating pantographs (DCC Only)
- Road number-specific details
- Three styles of roof vents
- Various vent hoods as appropriate
- Three styles of hood doors and end doors
- Full cab interior with lighted consoles
- Mo-Power capacitor system for uninterrupted DCC running
- DC/Silent (21-pin DCC Ready) or DC/DCC/ESU LokSound
- Suggested minimum radius: 22"



**CONTACT YOUR RETAILER OR ORDER DIRECT  
AT [RAPIDOTRAINS.COM](http://RAPIDOTRAINS.COM) / [RAPIDOTRAINS.CA](http://RAPIDOTRAINS.CA)**

**MSRP**  
No Sound **\$389.95 USD**  
w/Sound **\$499.95 USD**

No Sound **\$499.95 CAD**  
w/Sound **\$639.95 CAD**



**CANADA: 500 ALDEN ROAD • UNIT 21 • MARKHAM • ONTARIO • L3R 5H5**  
**USA: 382 HIGH STREET • BUFFALO • NEW YORK • 14204**  
**Tel. 905.474.3314. Toll Free 1-855-LRC-6917. Fax. 905.474.3325.**

**RAPIDO**

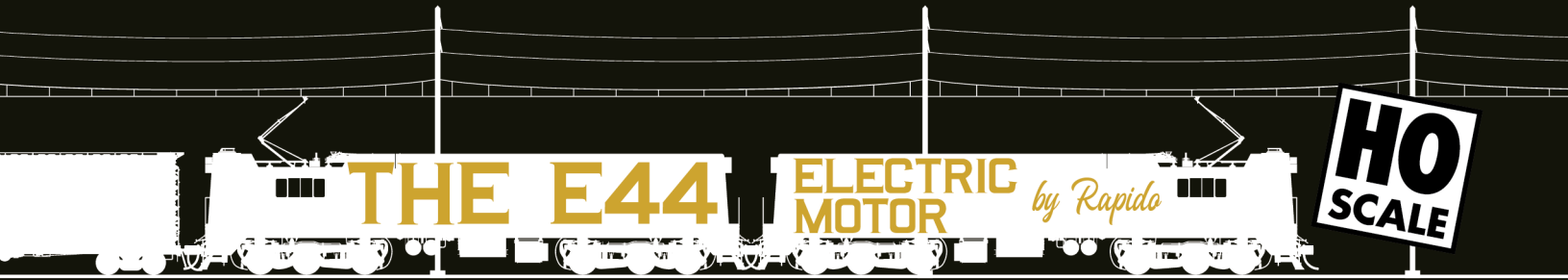

**ORDER DEADLINE: APRIL 15TH, 2026**

**OPERATING  
PANTOGRAPHS**

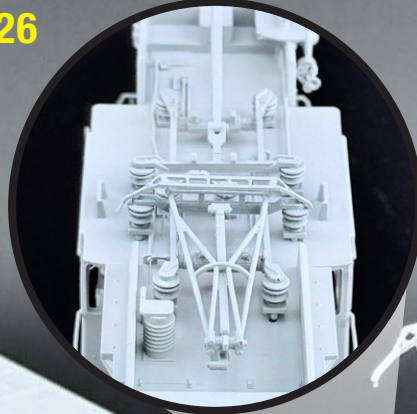

**LOK SOUND**  
EST. 1999

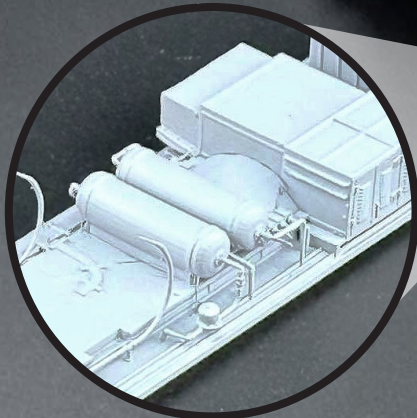
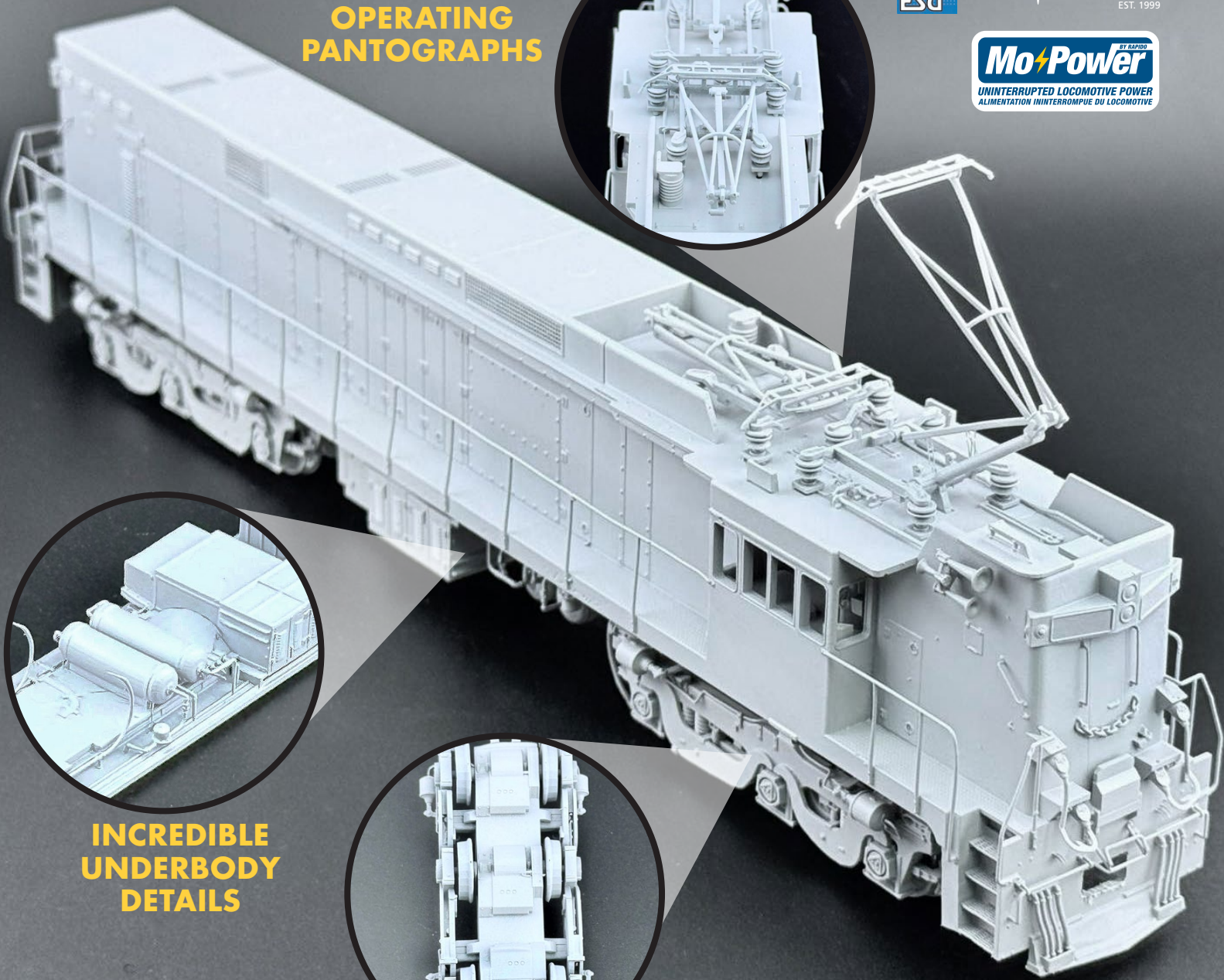

**INCREDIBLE  
UNDERBODY  
DETAILS**

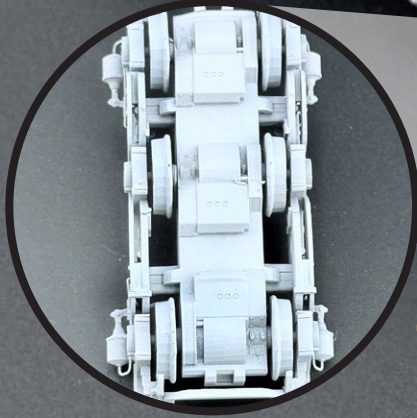

**TRACTION MOTOR  
DETAILS**

3D prints shown. Subject to revision.

**MSRP**

No Sound **\$389.95 USD**  
w/Sound **\$499.95 USD**

No Sound **\$499.95 CAD**  
w/Sound **\$639.95 CAD**



CANADA: 500 ALDEN ROAD • UNIT 21 • MARKHAM • ONTARIO • L3R 5H5  
USA: 382 HIGH STREET • BUFFALO • NEW YORK • 14204  
Tel. 905.474.3314. Toll Free 1-855-LRC-6917. Fax. 905.474.3325.

**RAPIDO**

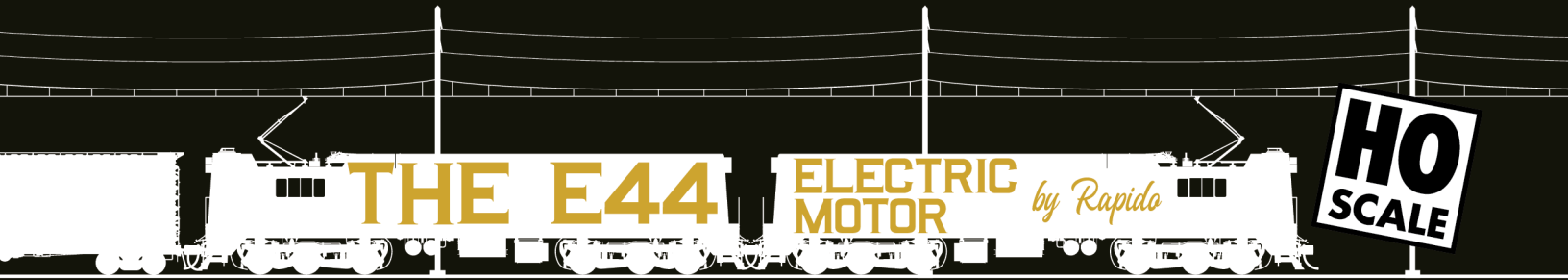

**ORDER DEADLINE: APRIL 15TH, 2026**

Faiveley Pantographs



No Vent Hoods and Smooth Doors

Leslie S3L Horn

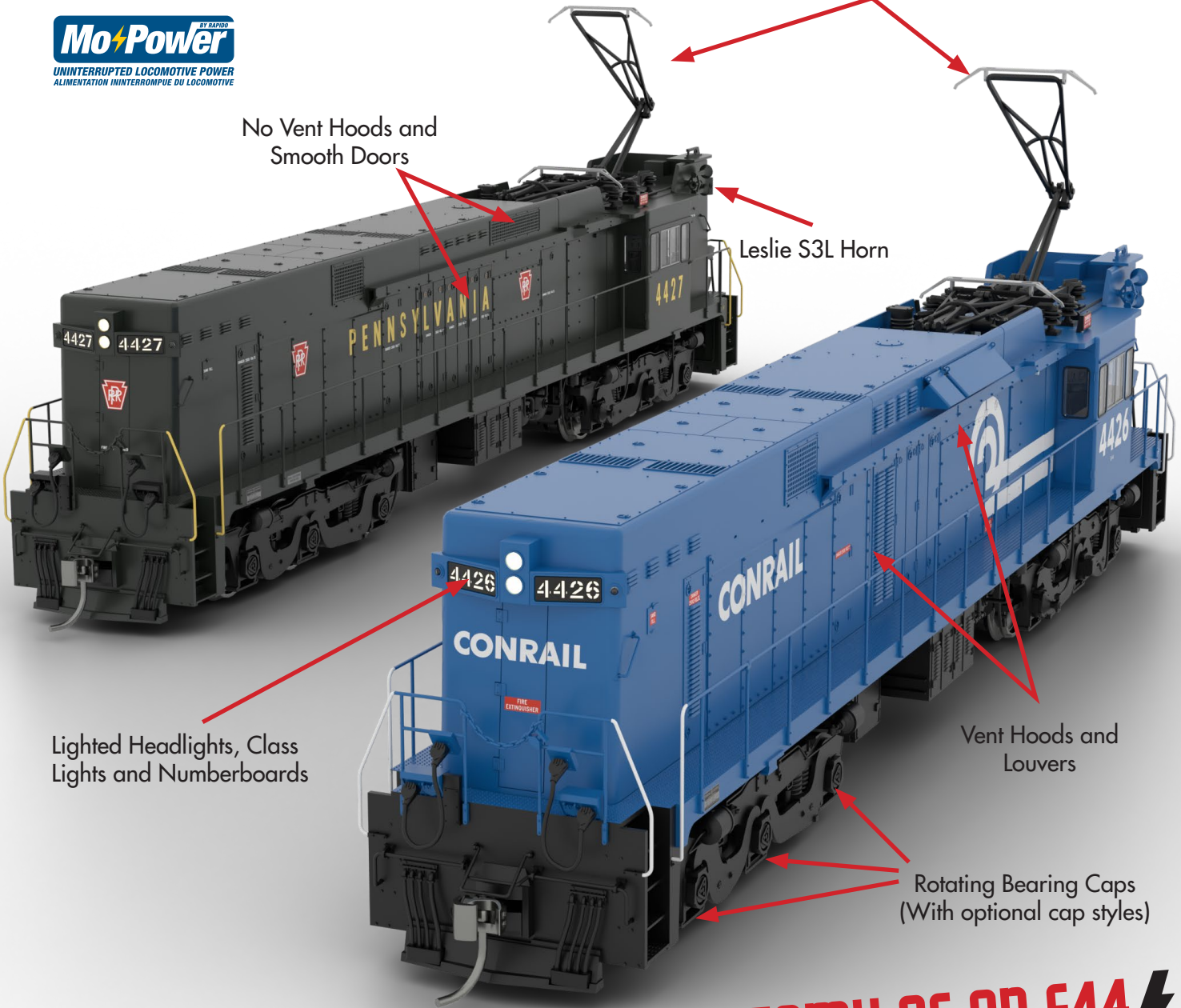

Lighted Headlights, Class Lights and Numberboards

Vent Hoods and Louvers

Rotating Bearing Caps (With optional cap styles)

# ⚡ ANATOMY OF AN E44 ⚡

3D CAD renders shown. Subject to revision.

**MSRP**  
No Sound **\$389.95 USD**  
w/Sound **\$499.95 USD**

No Sound **\$499.95 CAD**  
w/Sound **\$639.95 CAD**



CANADA: 500 ALDEN ROAD • UNIT 21 • MARKHAM • ONTARIO • L3R 5H5  
USA: 382 HIGH STREET • BUFFALO • NEW YORK • 14204  
Tel. 905.474.3314. Toll Free 1-855-LRC-6917. Fax. 905.474.3325.

**RAPIDO**

**ORDER DEADLINE: APRIL 15TH, 2026**

**THE E44**

**ELECTRIC MOTOR** *by Rapido*

**HO SCALE**



**Pennsylvania (E44/E44a)**

Road #	Item # (DC/Silent)	Item # (DC/DCC/Sound)
4432	52001 <input type="text"/>	52501 <input type="text"/>
4437	52002 <input type="text"/>	52502 <input type="text"/>
4445	52003 <input type="text"/>	52503 <input type="text"/>
4449	52004 <input type="text"/>	52504 <input type="text"/>
4461*	52005 <input type="text"/>	52505 <input type="text"/>
4465*	52006 <input type="text"/>	52506 <input type="text"/>

\*Denotes this motor is an E44a version.

**Penn-Central (E44/E44a)**

Road #	Item # (DC/Silent)	Item # (DC/DCC/Sound)
4431	52007 <input type="text"/>	52507 <input type="text"/>
4436	52008 <input type="text"/>	52508 <input type="text"/>
4439	52009 <input type="text"/>	52509 <input type="text"/>
4440*	52010 <input type="text"/>	52510 <input type="text"/>
4441*	52011 <input type="text"/>	52511 <input type="text"/>

\*Denotes this motor is an E44a version.



**Penn-Central (Red "P" - E44a)**

Road #	Item # (DC/Silent)	Item # (DC/DCC/Sound)
4442	52012 <input type="text"/>	52512 <input type="text"/>

**Conrail (Black Scheme - E44/E44a)**

Road #	Item # (DC/Silent)	Item # (DC/DCC/Sound)
4428	52013 <input type="text"/>	52513 <input type="text"/>
4430	52014 <input type="text"/>	52514 <input type="text"/>
4435	52015 <input type="text"/>	52515 <input type="text"/>
4444*	52016 <input type="text"/>	52516 <input type="text"/>
4448*	52017 <input type="text"/>	52517 <input type="text"/>
4453*	52018 <input type="text"/>	52518 <input type="text"/>

\*Denotes this motor is an E44a version.



**Conrail (Blue Scheme - E44/E44a)**

Road #	Item # (DC/Silent)	Item # (DC/DCC/Sound)
4426	52019 <input type="text"/>	52519 <input type="text"/>
4427	52020 <input type="text"/>	52520 <input type="text"/>
4429	52021 <input type="text"/>	52521 <input type="text"/>
4434	52022 <input type="text"/>	52522 <input type="text"/>
4456*	52023 <input type="text"/>	52523 <input type="text"/>
4458*	52024 <input type="text"/>	52524 <input type="text"/>

\*Denotes this motor is an E44a version.

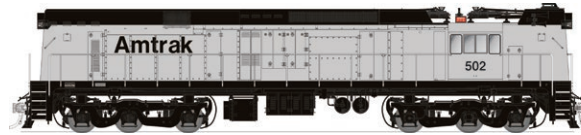

**Amtrak (Black/Silver - E44a)**

Road #	Item # (DC/Silent)	Item # (DC/DCC/Sound)
502	52025 <input type="text"/>	52525



**Amtrak (Phase III - E44a)**

Road #	Item # (DC/Silent)	Item # (DC/DCC/Sound)
501*	52026 <input type="text"/>	52526

\*Please note that the Amtrak Phase III E44a is a fantasy scheme officially licensed by Amtrak.

**CONTACT YOUR RETAILER OR ORDER DIRECT AT RAPIDOTRAINS.COM / RAPIDOTRAINS.CA**

**MSRP**  
 No Sound **\$389.95 USD**  
 w/Sound **\$499.95 USD**  

---

 No Sound **\$499.95 CAD**  
 w/Sound **\$639.95 CAD**



**CANADA: 500 ALDEN ROAD • UNIT 21 • MARKHAM • ONTARIO • L3R 5H5**  
**USA: 382 HIGH STREET • BUFFALO • NEW YORK • 14204**  
**Tel. 905.474.3314. Toll Free 1-855-LRC-6917. Fax. 905.474.3325.**

**RAPIDO**