

PURE GOLD

SAFETY CHUCKS

MIN. AIR PRESSURE

GOLDENROD
CORPORATION



CHOOSE THE INDUSTRY LEADER!

GOLDENROD SAFETY CHUCKS

GOLDENROD's extensive line of rugged safety chucks provide roll shaft support and torque transmission at a low cost. The maintenance-free design ensures optimal performance throughout the life of each safety chuck. Goldenrod's design safe-guards your equipment by securing the roll shaft in place during any wind or unwind operation. Our safety chucks will only open with the socket in the upright position. Available for either foot or flange mounting, these safety chucks complement Goldenrod's complete line of multi-bladder air shafts, offering you a complete package with seamless installation and operation.

Goldenrod Safety Chucks offer the following advantages:

- Tilt plate or Slide ring handwheel models
- Redundant handwheel lock mechanism (a must for turrets)
- Long, maintenance-free life
- Durable construction with cast iron housing
- Chrome plated, steel hand-wheel
- Shaft socket hardened to Rockwell 56C
- Free turning precision ball bearings
- Finger guards on all models
- Shaft extensions with keyway
- Foot or flange mounting
- Metric size sockets available upon request
- "U", "V" or "VO" replaceable inserts
- Drop in replacement chucks for many brands

In addition to the standard safety chucks used for typical unwind/rewind stations, we offer:

- Side-lay adjustable chucks - up to 2 full inches of stroke
- Air through passage for use with rotary unions
- Automatic air open/close models
- Skew based models for addressing baggy edges

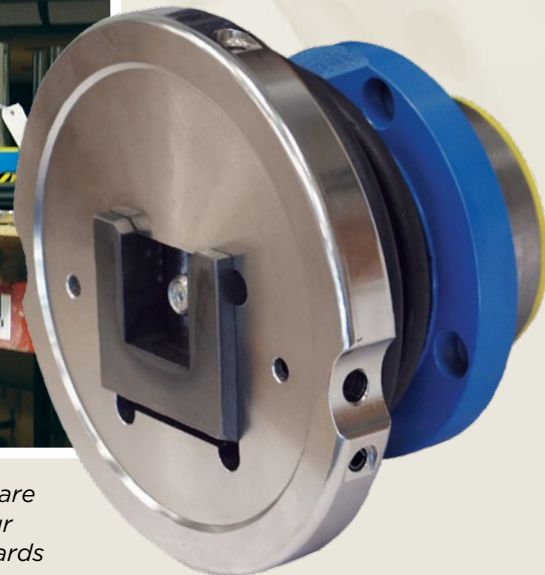
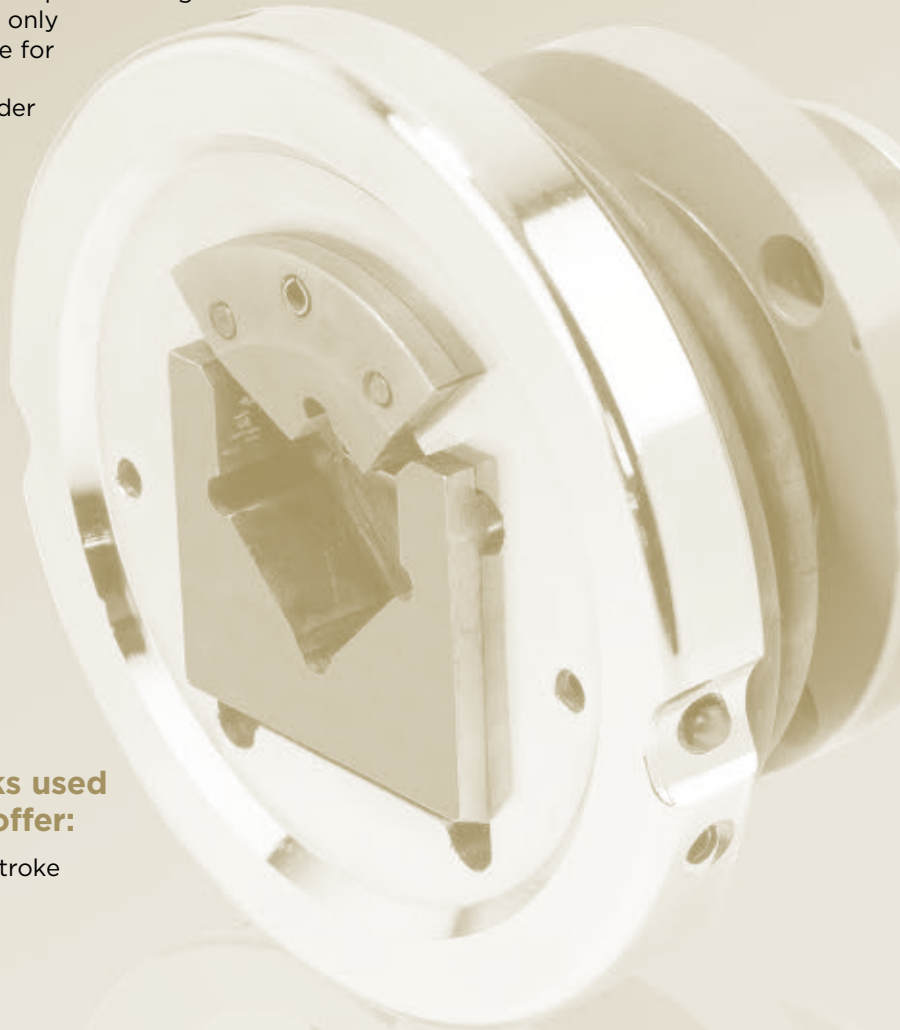

Goldenrod maintains a huge inventory of many different standard models and spare parts to handle your immediate needs and can also offer custom solutions to your more complex problems. All chucks are manufactured to ISO 9002 quality standards and are fully inspected before leaving the factory.

AVAILABLE SOCKET SHAPES

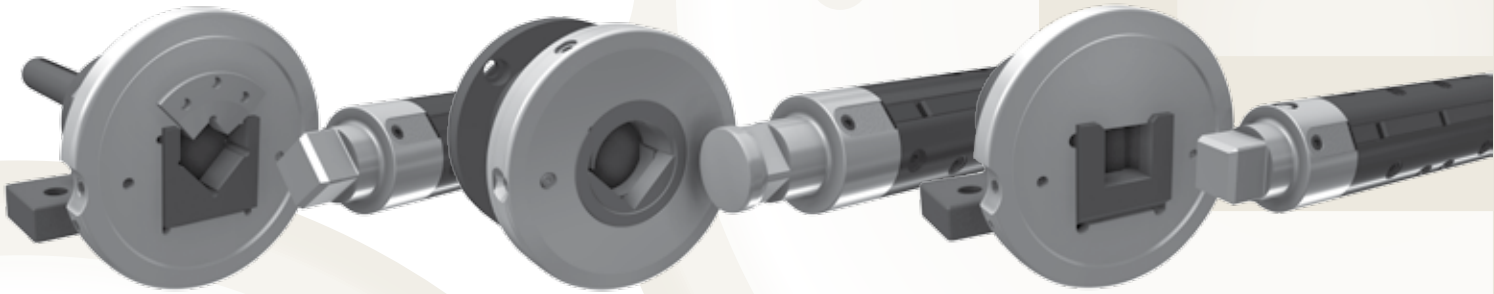

“V” Sockets

The square “V” socket designs will aid the operator with shaft location and insertion.

“VO” Sockets

The patented “VO” (square/round) socket design features an outer diameter for journal support and an inner square to provide the drive force. The continuous 360 degree supporting surface allows for smooth and quiet chuck rotation at any speed.

“U” Sockets

The standard square “U” chuck socket design is available on all of our standard safety chucks.

AUTOMATION FEATURES:

Air-Thru Passage

Air-Thru Passage: Automatically pressurizes air shafts. Air passes through the idler or shafted chuck. Retractable air nozzle seals against journal end. Used with Goldenrod's standard and differential shafts and turret winders.



Output Signals

To confirm OPEN or confirm CLOSE to your controller. Light a light, ring a bell, etc.

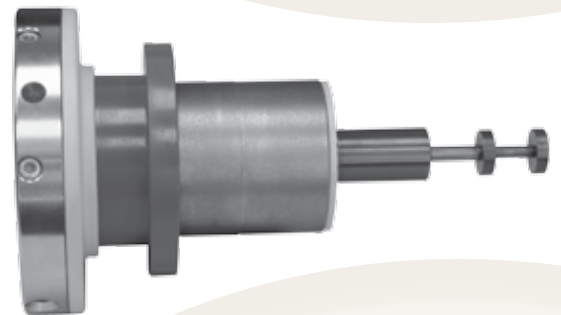

DROP-IN REPLACEMENT CHUCKS

All of our chucks are available in foot or flange mounting and can be adapted to your existing configuration. Our 901/902 and 911/912 Series chucks serve as DROP-IN replacements for most competitive brands. Stock chucks are offered for 19 - 25, 22 - 30, 30 - 40, and 40 - 50 models. We have many OEM specific designs for press and converting machine manufacturers both foreign and domestic.

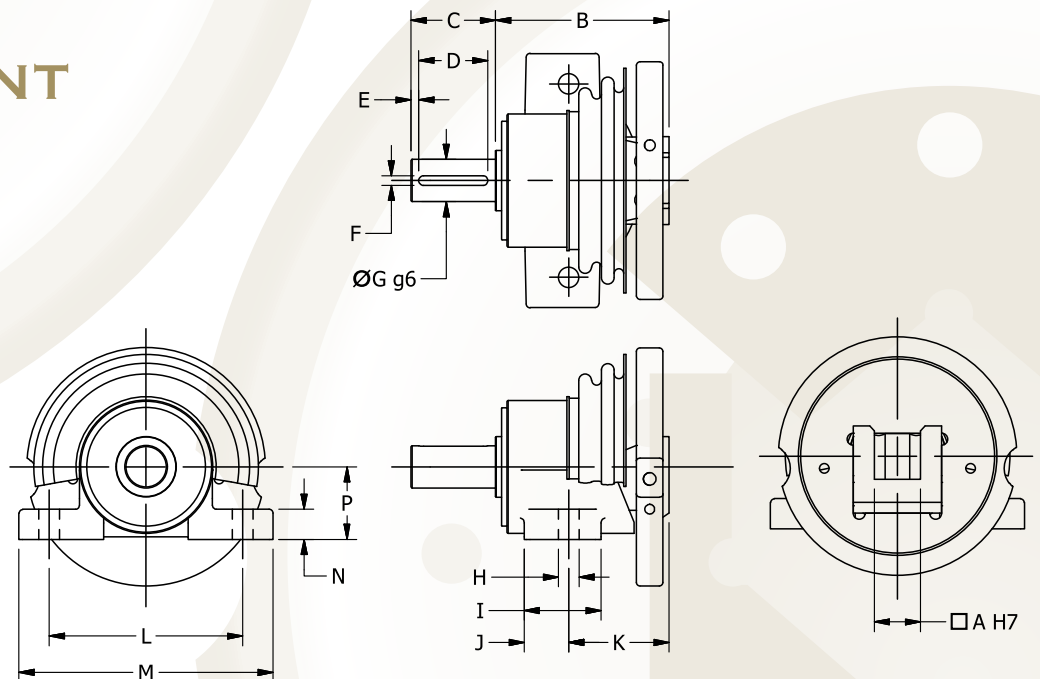

HORIZONTAL SLIDE LOCKING RING 927 SERIES

with replaceable “V” or “VO” sockets

Flange or Foot Mount

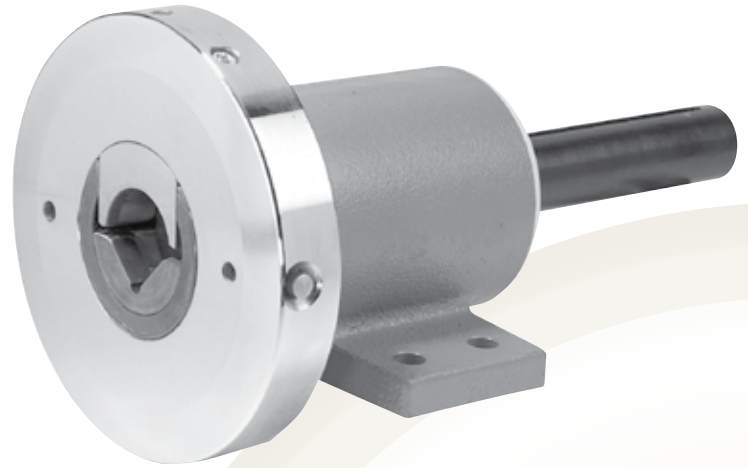

926 SERIES

The 926 Series is a more durable design as compared to our standard 927 Series. This slide ring chuck includes a forged steel closing ring and heavy duty roller cam for reduced wear. This new design extends chuck life and provides for improved overall performance.

Model	Socket Shape	Duty Type	Load Size	Dimensions	Max. Torque (each)
927/KLSL	V or VO	Light Duty	1200 lb. load per chuck @ 1000 RPM	To 1 ³ / ₈ " Square Journals	516 ft. lbs.
927/KLL	V or VO	Medium Duty	1750 lb. load per chuck @ 1200 RPM	To 1 ¹ / ₂ " Square Journals	695 ft. lbs.
927/KLP	V or VO	Heavy Duty	3400 lb. load per chuck @ 1500 RPM	To 2" Square Journals	969 ft. lbs.
927/KLU	V or VO	Xtra Heavy Duty	6750 lb. load per chuck @ 1200 RPM	To 3" Square Journals	1,687 ft. lbs.
926/KLL	V or VO	Medium Duty	1750 lb. load per chuck @ 1200 RPM	To 1 ¹ / ₂ " Square Journals	695 ft. lbs.
926/KLP	V or VO	Heavy Duty	3400 lb. load per chuck @ 1500 RPM	To 2" Square Journals	969 ft. lbs.

TILT PLATE LOCK LOCKING RING 900/910 SERIES

Flange or Foot Mount

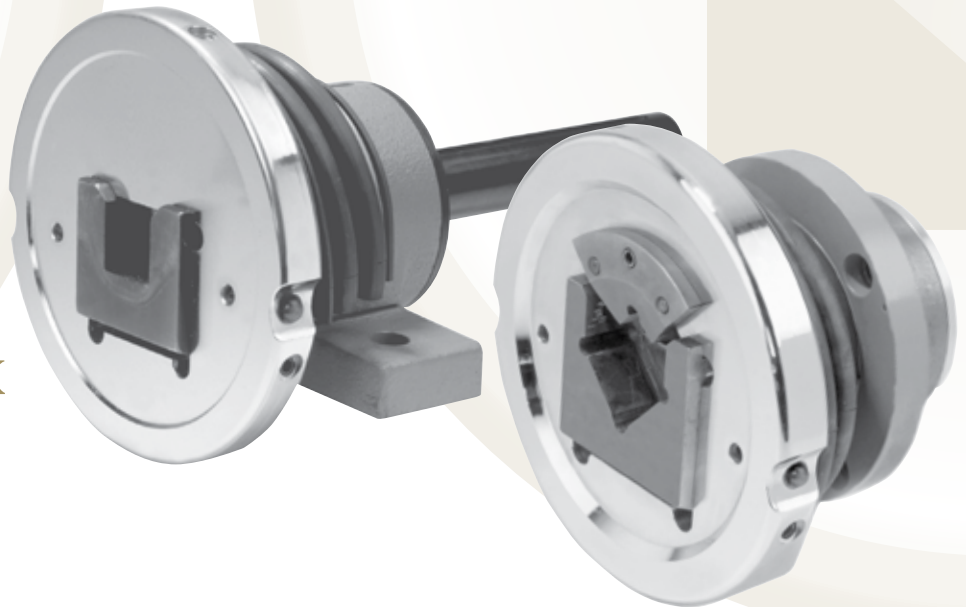

Model	Socket Shape	Duty Type	Load Size	Dimensions	Max. Torque (each)
900/KLL	U	Light Duty	675 lb. load per chuck @ 600 RPM	To 1 ¹ / ₄ " Square Journals	174 ft. lbs.
900/KLP	U	Medium Duty	2200 lb. load per chuck @ 1000 RPM	To 2" Square Journals	738 ft. lbs.
910/KLP	V	Medium Duty	1700 lb. load per chuck @ 1000 RPM	To 2" Square Journals	522 ft. lbs.

ADJUSTABLE SIDELAY CHUCKS

Flange or Foot Mount

GOLDENROD's Manual Sidelay chucks for lateral positioning of core shaft and material roll up to plus/minus 1" standard.

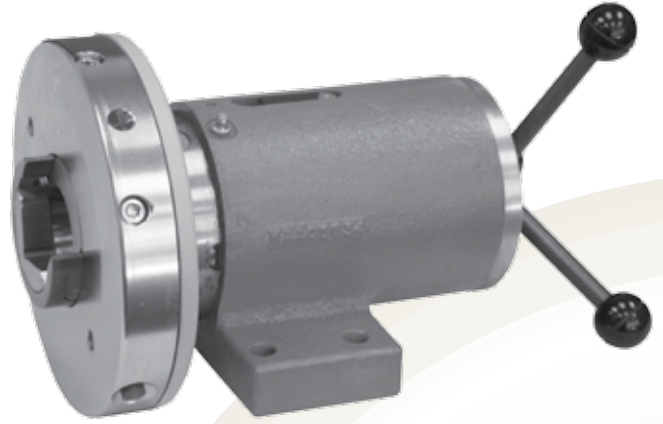
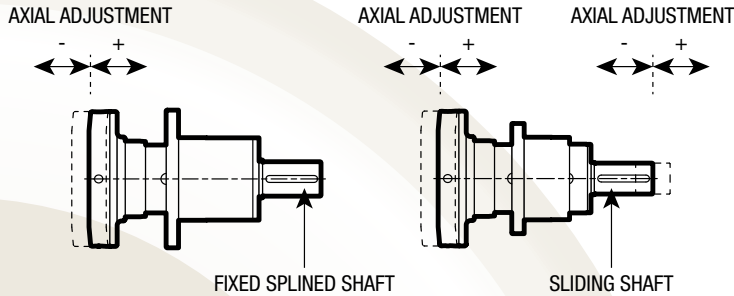

Sidelay Options:

Extension remains in fixed stationary position splined or slides proportional to chuck movement.

Model	Socket Shape	Duty Type	Load Size	Dimensions	Max. Torque (each)
952/KLL-Slide Ring	VO	Medium Duty	2200 lb. load per chuck @ 1200 RPM	1 1/4" Square x 1 3/4" Round	695 ft. lbs.
952/KLP-Slide Ring	VO	Heavy Duty	4000 lb. load per chuck @ 1500 RPM	1 1/2" Square x 2" Round	969 ft. lbs.
955/PNL-Slide Ring Plus "Air Open/Close"	VO	Medium Duty	2200 lb. load per chuck @ 1200 RPM	1 1/4" Square x 1 3/4" Round	695 ft. lbs.
955/PNP-Slide Ring Plus "Air Open/Close"	VO	Heavy Duty	4000 lb. load per chuck @ 1500 RPM	1 1/2" Square x 2" Round	969 ft. lbs.

AIR "OPEN AND CLOSE" CHUCKS

Flange or Foot Mount

GOLDENROD's line of "air open/close" chucks allow the operator to open/close the chuck closing ring manually with an air gun or automatically from a remote location.



Manual Inflation

Automatic Inflation



Model	Socket Shape	Duty Type	Load Size	Dimensions	Max. Torque (each)
935/PNLTR 936/PNLTF	V or VO	Medium Duty	1750 lb. load per chuck @ 1200 RPM	To 1 1/2" Square Journals	735 ft. lbs.
935/PNPTR 936/PNPFT	V or VO	Heavy Duty	3375 lb. load per chuck @ 1500 RPM	To 2" Square Journals	958 ft. lbs.



Founded in 1986, Goldenrod Corporation is a leading North American manufacturer of winding shafts, chucks and related equipment for the converting, paper, film, foil, textile and metals industries. The Goldenrod/Svecom partnership is the largest manufacturer of winding shafts, chucks, and shaft handling equipment in the world. We are a truly global company dedicated to one thing - servicing the needs of our customers.



GOLDENROD
CORPORATION
PARTNERED WITH SVECOM P.E.



P.O. Box 95 • 25 Lancaster Drive, Beacon Falls, CT 06403 USA
Toll Free 1-800-465-3763 (GOLDROD) • Tel. (203) 723-4400 • FAX (203) 723-8230

www.goldenrodcorp.com