

PRIMEFLIGHT UV™ BAGGAGE UNIT

FEATURES >

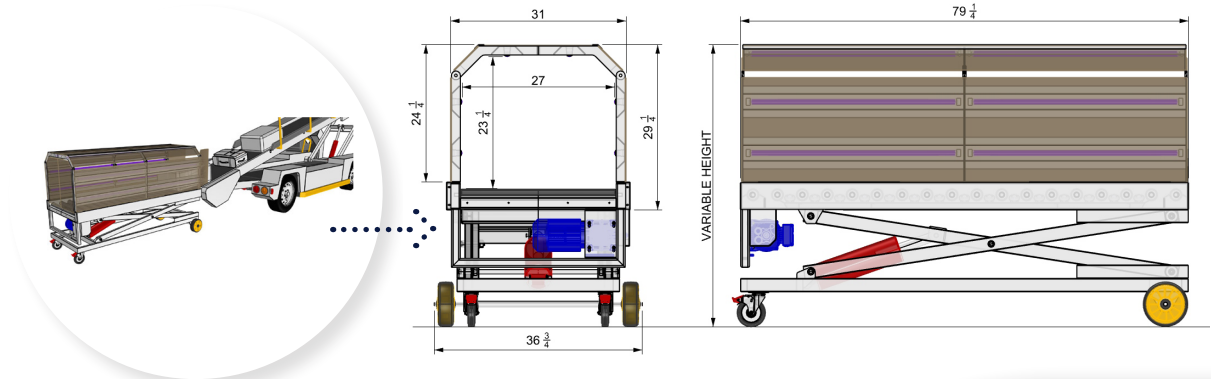
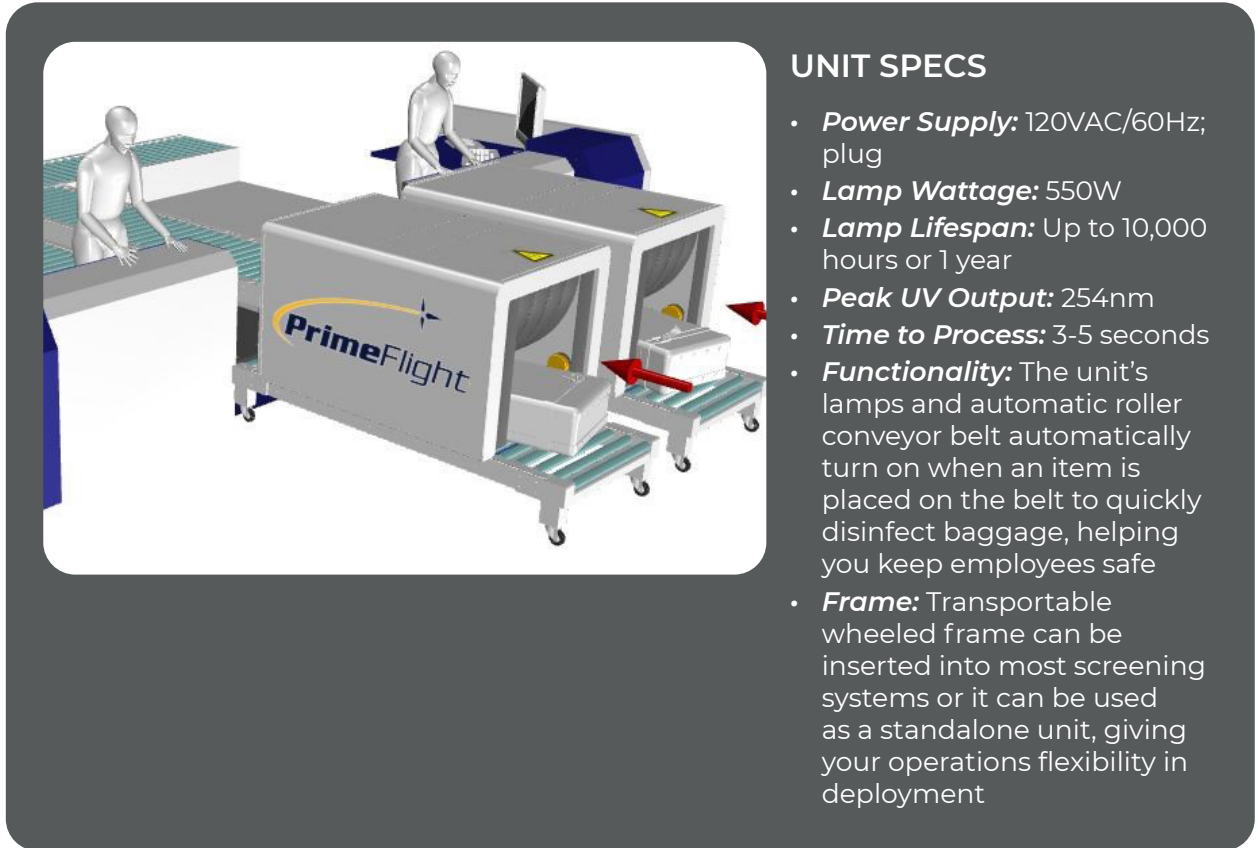
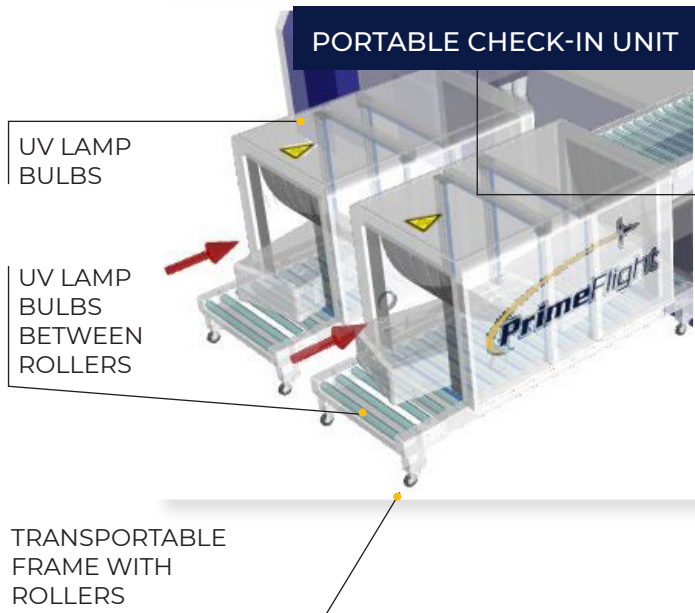
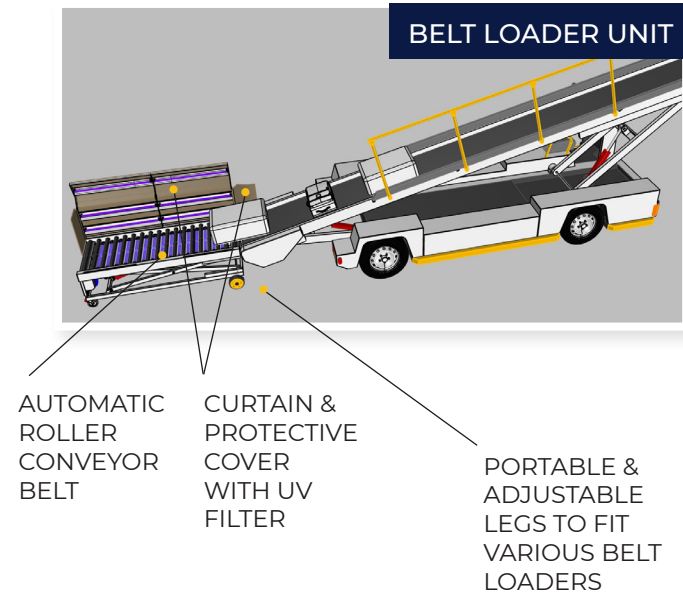

FOR MORE INFORMATION

 primeflight.com/primeflightUV

 info@primeflight.com

Patents Pending. Copyright©2020 PrimeFlight Aviation Services, Inc. All rights reserved.

