

# PRIMEFLIGHT UV™ CHECK-POINT UNIT

## FEATURES >

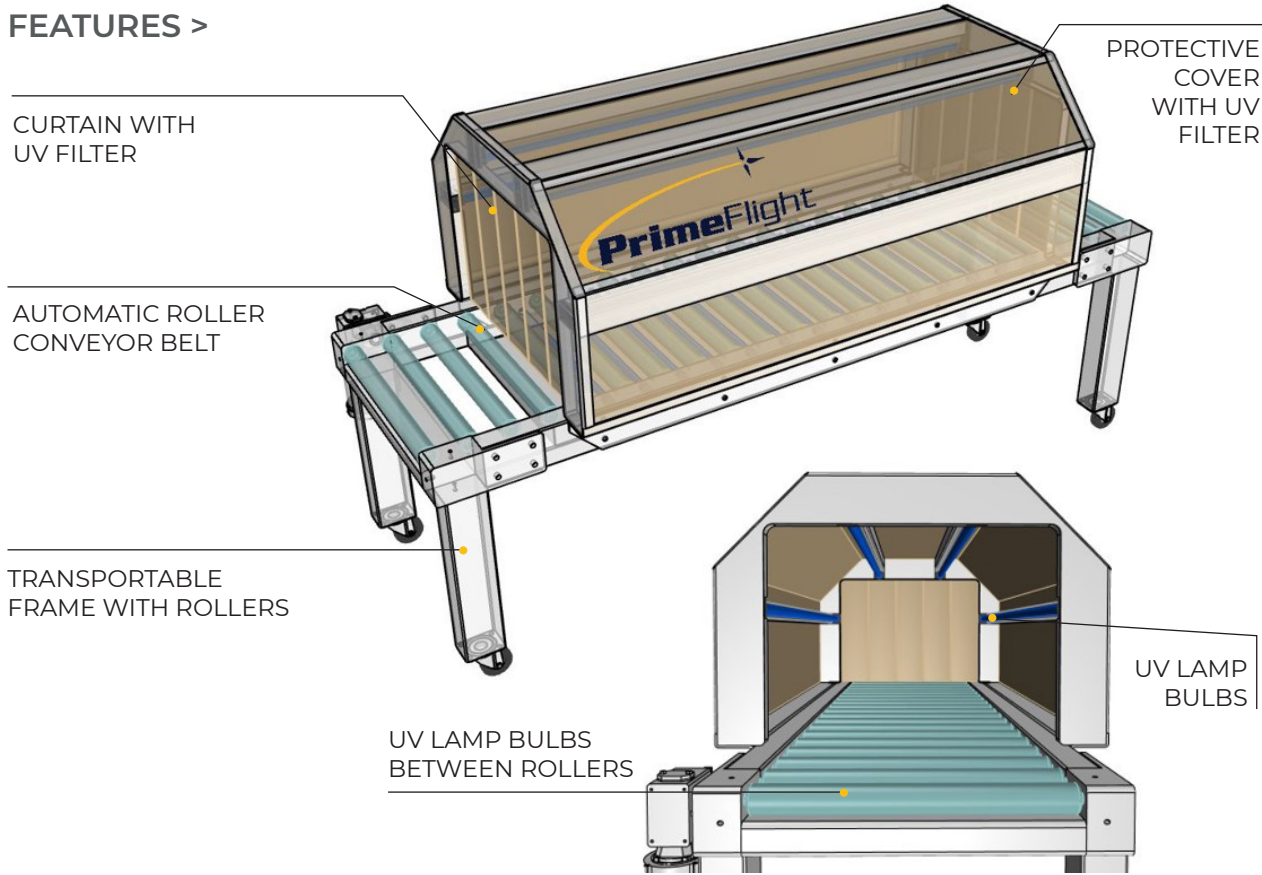

## UNIT SPECS

- **Power Supply:** 120VAC/60Hz; plug
- **Lamp Wattage:** 550W
- **Lamp Lifespan:** Up to 10,000 hours or 1 year
- **Peak UV Output:** 254nm
- **Time to Process:** 3-5 seconds
- **Functionality:** The unit's lamps and automatic roller conveyor belt automatically turn on when an item is placed on the belt to quickly disinfect belongings, helping you keep agents safe during the baggage screening process
- **Frame:** Transportable wheeled frame can be inserted into most screening systems or it can be used as a standalone unit, giving your operations flexibility in deployment

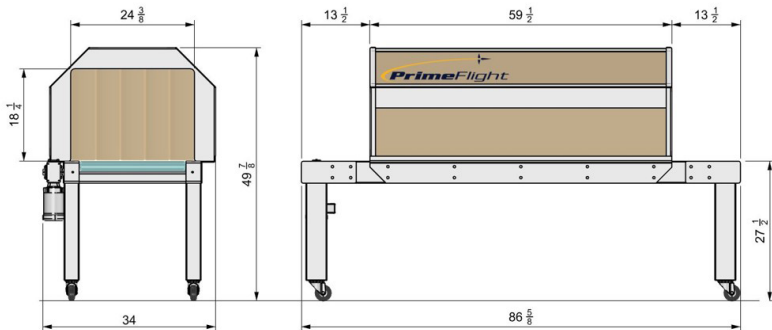

## DIMENSIONS (INCHES) ^

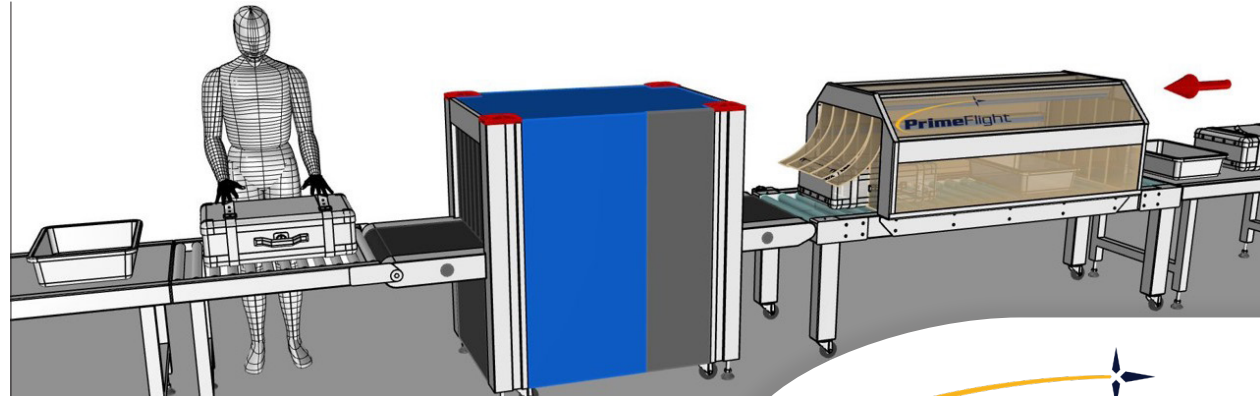

FOR MORE INFORMATION

 [primeflight.com/primeflightUV](http://primeflight.com/primeflightUV)

 [info@primeflight.com](mailto:info@primeflight.com)

Patents Pending. Copyright©2020 PrimeFlight Aviation Services, Inc. All rights reserved.

