

# PRIMEFLIGHT<sup>UV</sup>™ SECURITY BIN UNIT

## FEATURES >

PROTECTIVE COVER WITH UV FILTER

EASY TO LOAD CHAMBER

BINS SLIDE IN TO ENSURE QUICK RELOAD

CURTAINS BLOCK UV LIGHT

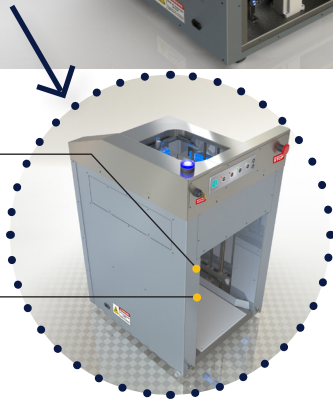

## UNIT SPECS

- **Power Supply:** 120VAC/60Hz; plug
- **Lamp Wattage:** 240W
- **Lamp Lifespan:** Up to 10,000 hours or 1 year
- **Features:** PLC Control, Stepper Motor
- **Time to Process:** 6-8 seconds
- **Functionality:** The unit's lamps disinfect bins that are automatically fed from an easy-to-load lower chamber to ensure high touch bins are continuously being disinfected
- **Frame:** The automated disinfection unit is compact with a 25" x 30" footprint and can be added to existing security systems giving your operations flexibility in deployment

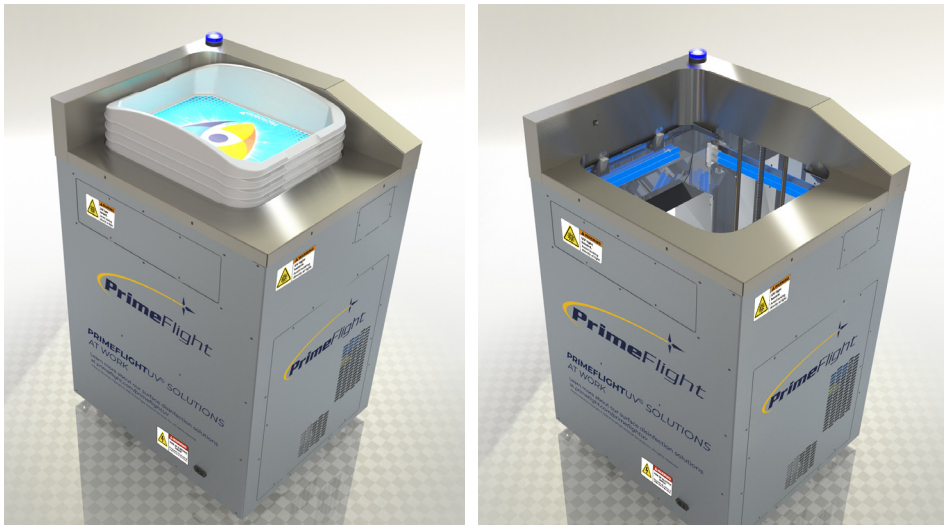
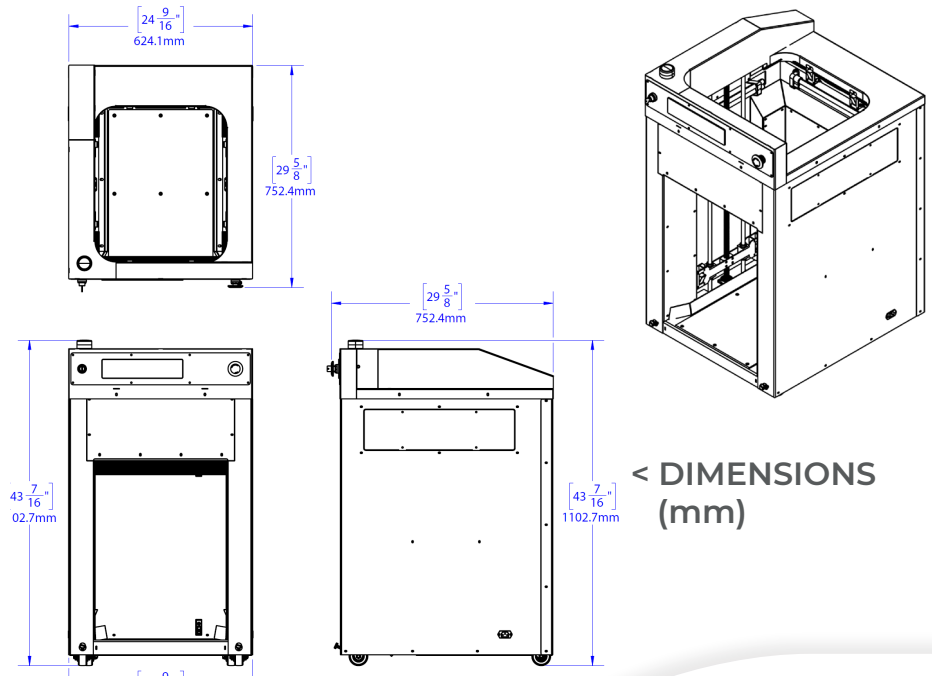

FOR MORE INFORMATION

 [primeflight.com/primeflightUV](http://primeflight.com/primeflightUV)

 [info@primeflight.com](mailto:info@primeflight.com)

Patents Pending. Copyright©2020 PrimeFlight Aviation Services, Inc. All rights reserved.

