

product code _____

serial number _____

date of manufacturing _____

date of first service _____

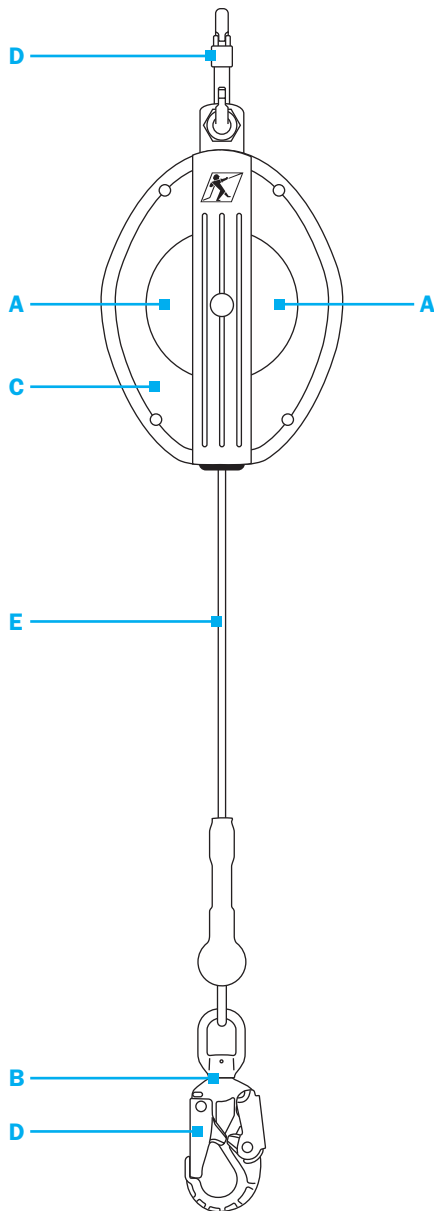

LABELS

First look for product information, date of manufacturing and date of inspection.

A		Pass	Fail
▪ Present		Pass	Fail
▪ Legibility		Pass	Fail

HARDWARE

FALL INDICATOR

B Check to see if the red band on the snap hook is visible.

▪ Red band		Pass	Fail
------------	--	------	------

HOUSING

▪ Cuts/Cracks/Punctures		Pass	Fail
C ▪ High abrasion/wear		Pass	Fail
▪ Evidence of modification		Pass	Fail
▪ Chemical and heat damage		Pass	Fail

ANCHORAGE CONNECTORS

D ▪ Present		Pass	Fail
▪ Abrasion (tolerance 1%)		Pass	Fail
▪ Evidence of modification/deformation		Pass	Fail

WIRE ROPE

Run the wire rope through your hands to conduct a tactile examination on all sides of the wire rope.

▪ High abrasion/wear (tolerance 1%)		Pass	Fail
E ▪ Broken wire or strand		Pass	Fail
▪ Excessive corrosion		Pass	Fail
▪ Heat damage		Pass	Fail
▪ Kinking, crushing or bird caging			
▪ Reduction of diameter (tolerance 5%)			

LOCKING MECHANISM

- ▪ Function		Pass	Fail
--------------	--	------	------

- Result: Back in service
 Must be cleaned
 Return for repair
 Remove from service and destroy

inspected by _____

date _____

signature _____