

CBT for Front-Line Medical Professionals: Brief Interventions During a Time of Crisis

ALLEN R. MILLER, PH.D., M.B.A.

*Director, CBT Programs
Beck Institute for Cognitive Behavior Therapy*

April 4, 2020



beckinstitute.org

©2020 Beck Institute for Cognitive Behavior Therapy

Any unauthorized use or circulation is strictly prohibited.

Dr. Aaron T. Beck developed CBT at the University of Pennsylvania in the 1960s. In 1994, Dr. Beck and his daughter, Dr. Judith Beck, established Beck Institute.

Beck Institute is a leading international source for training, therapy, and resources in Cognitive Behavior Therapy (CBT).

About Beck Institute

Our mission is to **improve lives worldwide** through excellence in Cognitive Behavior Therapy.

Join the CBT Conversation

beckinstitute.org

Sign up for the Beck Institute
newsletter

beckinstitute.org/subscribe

Agenda

- The Situation
- Values clarification
- CBT Model
- Cognitive Conceptualization
 - Depression
 - Anxiety
 - Anger
- Cost-Benefit Analysis
- Socratic Questions
- Distress Tolerance
- Emotional Regulation
- Sleep Hygiene
- Activity Monitoring and Planning
- Breathing and Mindfulness
- Interpersonal Effectiveness
- CBT-Hopelessness
- Action Plans
 - Coping Cards
 - Imagery
 - Behavioral Experiments

The Situation

Mental health during COVID-19: AMA

During a crisis such as the COVID-19 pandemic, **it is common for everyone to experience increased levels of distress and anxiety**, particularly as a result of **social isolation**. Physicians and other frontline health care professionals are particularly vulnerable to negative mental health effects as they **strive to balance the duty of caring for patients with concerns about their own well-being and that of their family and friends**.

[THE ETHICIST: By Kwame Anthony Appiah](#)

Values Clarification:

https://www.nytimes.com/2020/03/30/magazine/coronavirus-medical-ethics.html?campaign_id=52&emc=edit_ma_20200403&instance_id=17294&nl=the-new-york-times-magazine®i_id=71289774&segment_id=23739&te=1&user_id=2049670c30aa042ad5a6b2ff8a46379d

Stressors

- Volumes and acuity
- Possibility of infection
- Long shifts
- Inability to save all patients
- Shortness of supplies
- Under-preparedness
- Separation from partners/children/other family/friends

Normal Adjustment Issues

- Overwhelmed by volumes and acuity
- Fear of infection
- Guilt over inability to save all
- Frustration over lack of supplies
- Anger about under-preparedness
- Miss partners/children
- Exhausted
- Depression
- Anxiety
- Insomnia
- Stress
- Substance use
- Feel lonely
- Miss social activities
- Miss hobbies
- Bored

<https://www.inquirer.com/health/coronavirus/coronavirus-covid19-mental-health-doctors-20200327.html>

<https://jamanetwork.com/journals/jamanetworkopen/fullarticle/2763229>

Common Goals

- Get control (<https://beckinstitute.org/using-cbt-to-respond-to-covid-19/>)
- Resolve ethical concerns: Work vs family
- Reduce Fear: Regarding exposure
- Lower anxiety: Worry less
- Improve mood: More pleasure, competence
- Limit anger: Towards, pandemic, employer, government, self, others
- Healthy lifestyle: Eat, sleep, exercise

CBT Model for Crisis Intervention

Crisis Intervention (Not linear)

- First Aid: Physical needs, Safety, Social connections
- Conceptualization: Cause, maintenance
- Prioritize needs: Values, Priorities, Problem solve, Goals
- Coping Strategies: For what I cannot change

Crisis Intervention (Not linear)

- Change Efforts: For what I can control
- Challenges: How do I (colleague) get in the way
- Acceptance: It is what it is

CBT Values

- Demonstrate Understanding: Listen, empathize
- Interpersonal Effectiveness: Unconditional acceptance
- Conceptualization
- Focus on one issue
- Collaboration



CBT Techniques for Crisis Intervention

- Socratic Questions
- Cognitive Restructuring
- Behavioral Activation
- Cost-Benefit Analysis
- Role Play
- Imagery
- Relaxation
- Mindfulness
- Distress Tolerance
- Emotion Regulation
- Acceptance
- Value Identification
- Motivation
- Coping Cards
- Feedback
- Action Plans

Cognitive Conceptualizations

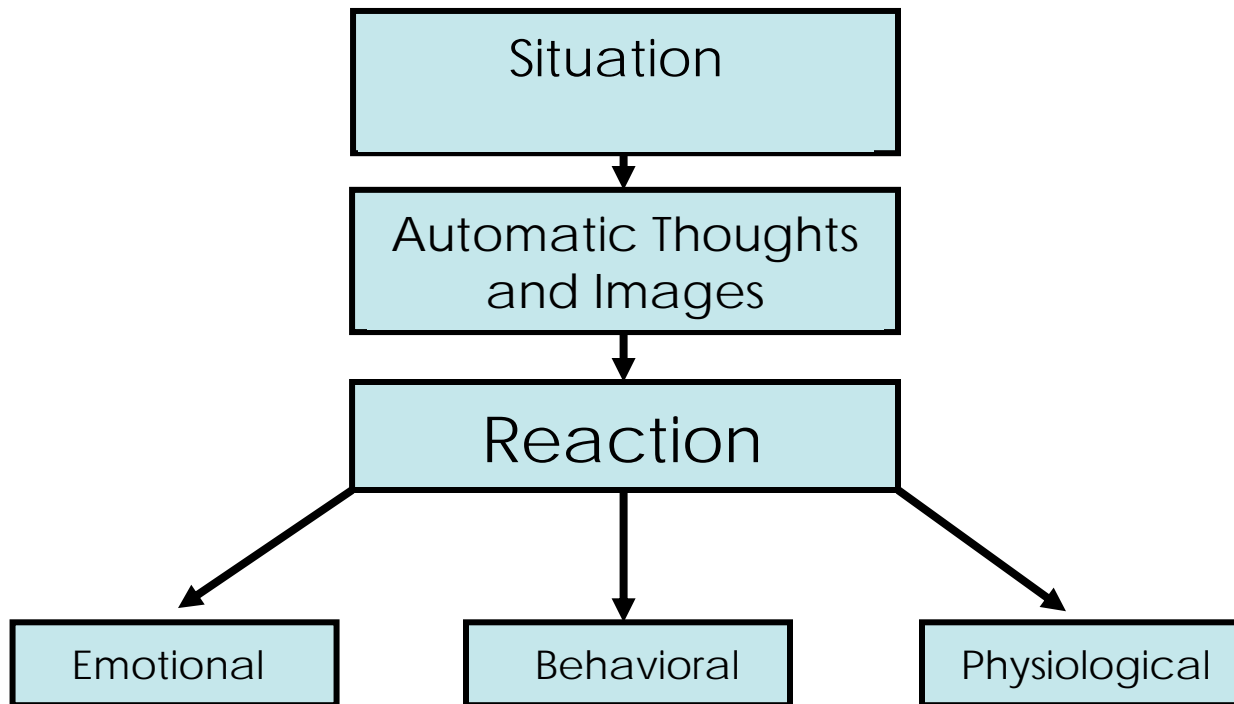

Depression

Cognitive Model for Depression

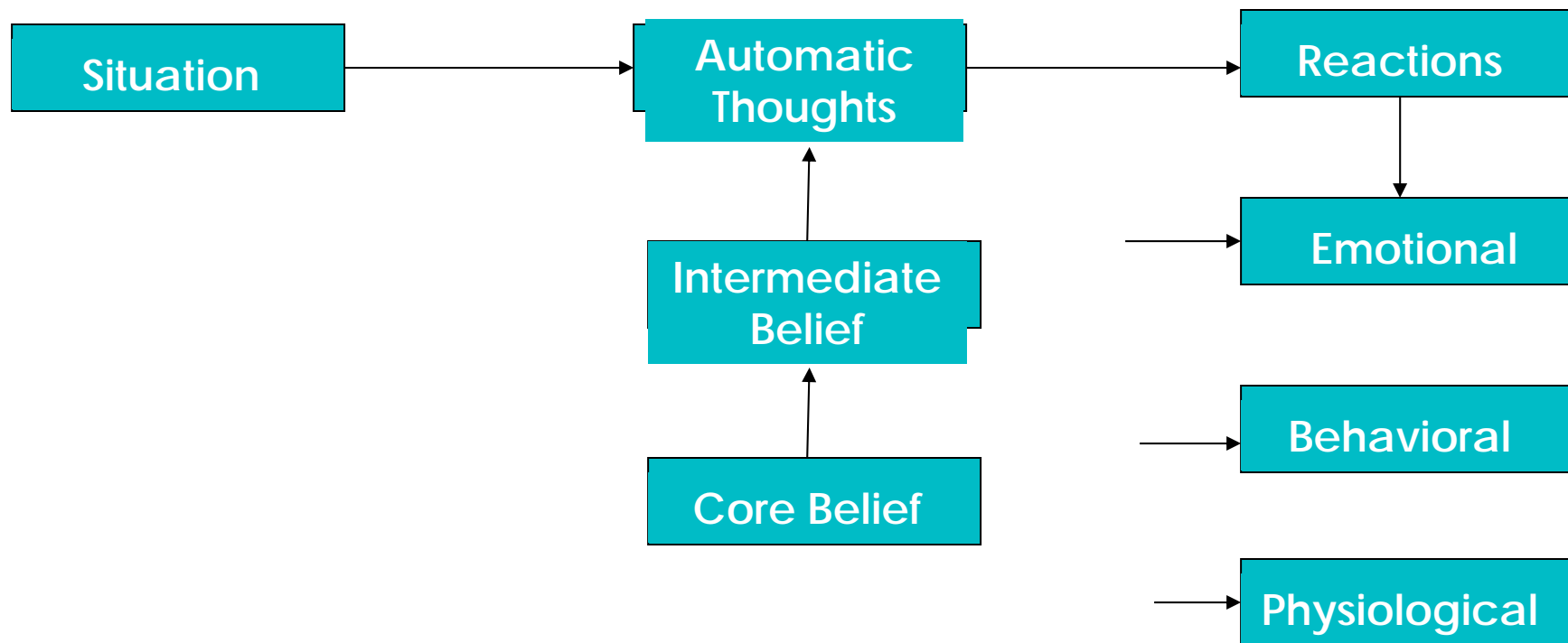

Beck, J. (1995). Cognitive Therapy: Basics and Beyond. Guilford. New York.

Common Thoughts of Depression

- Can't do my job
- Can't be in my house
- I miss my family/kids/grandchildren
- Can't be a good partner in relationship
- No end in sight
- The situation is hopeless

ANXIETY

The Vicious Cycle

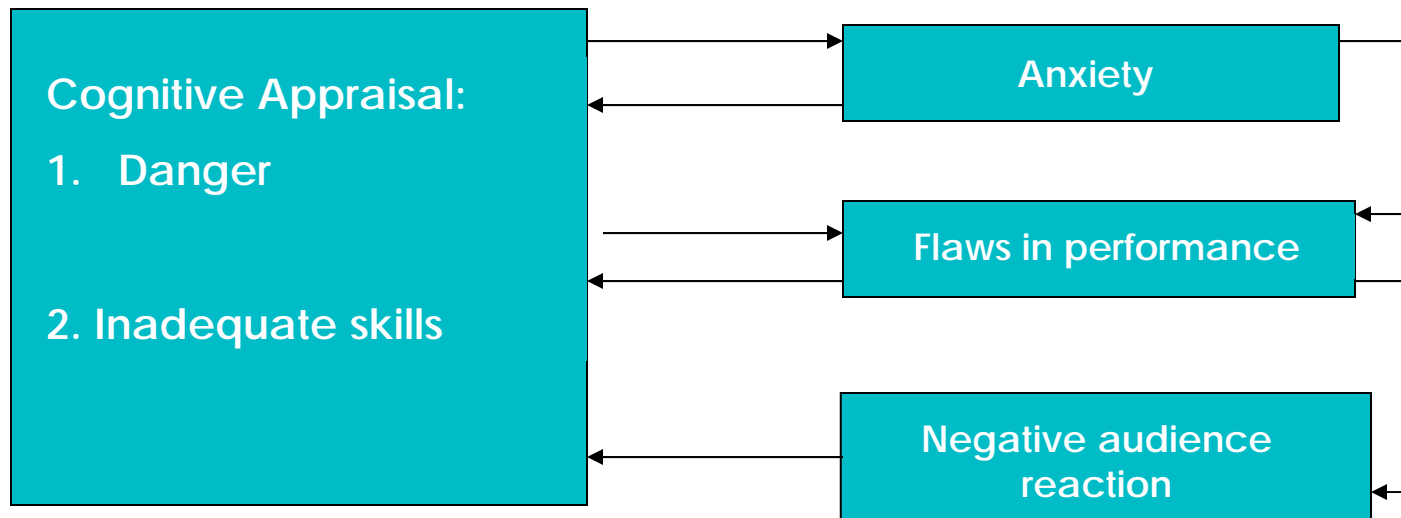

Beck, A.T. and Emery, G. (1985). Anxiety Disorders and Phobias. Basic Books. New York.

Common Thoughts of Anxiety

- If might become infected
- I could get sick/die
- There are too many cases, I can't handle the work load
- The acuity is too high. I can't give cases the attention they need.
- My patient(s) might die

ANGER

Cognitive Model of Anger

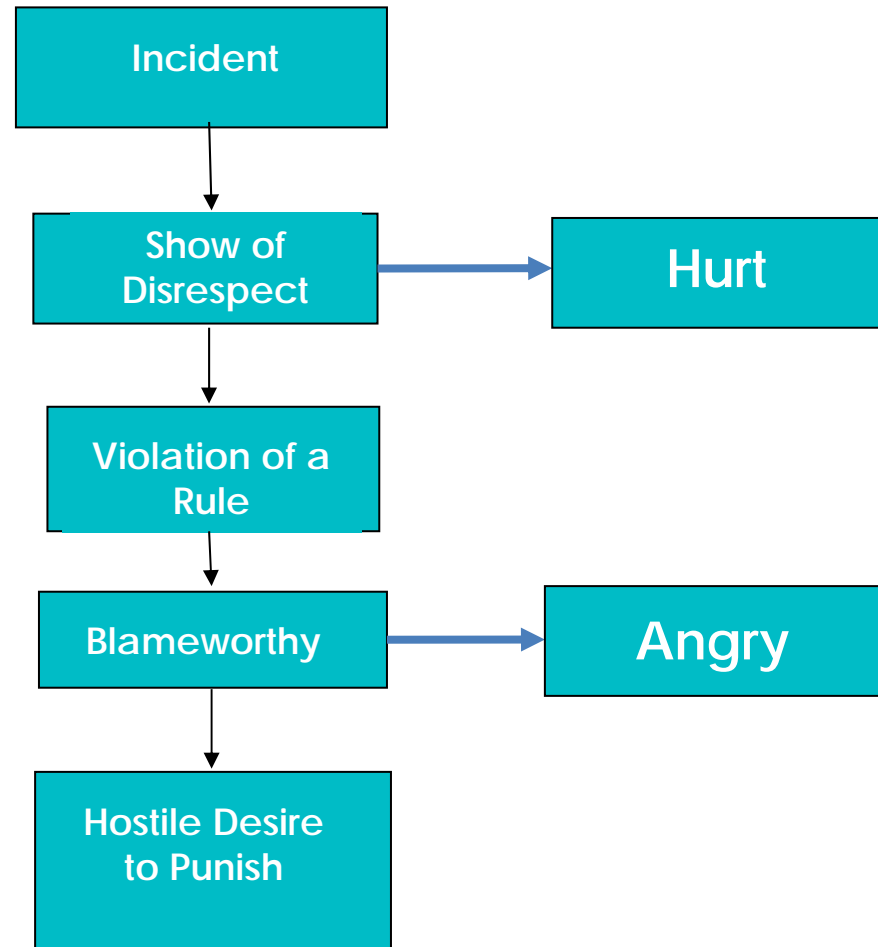

Common Thoughts of Anger

- This isn't fair, I don't deserve this.
- They knew it was coming
- We don't have enough PPE
- There are no ventilators
- We are running out of meds
- They lie to us

Cost-Benefit Analysis

Advantages-Disadvantages Analysis

- Useful when a client has important decisions to make
- Useful if clients are having difficulty taking steps towards a particular goal
- Helps client organize his or her thoughts about an issue

Advantages-Disadvantages Analysis

Advantages of...	Disadvantages of...
Advantages of Not...	Disadvantages of Not...

ITCH for Problem-Solving

- Identify the Problem.
- Think about possible solutions.
- Choose a solution to implement.
- How well does it work?

Muñoz, R.F. Ippen, C.G. Rao, S. Le, H-N, Dwyer, E.V. (2000). Manual for group cognitive-behavioral therapy of major depression. medschool2.ucsf.edu/latino/pdf/CBTDEN/overview.pdf

Socratic Questions

Socratic Questions for Guided Discovery

- What is the evidence that my thought is true?
What is the evidence that my thought is not true?
- What's an alternative explanation or viewpoint?
- What's the worst thing that could happen and how would I cope if it did?
- What's the best that could happen?
- What's the most likely outcome?

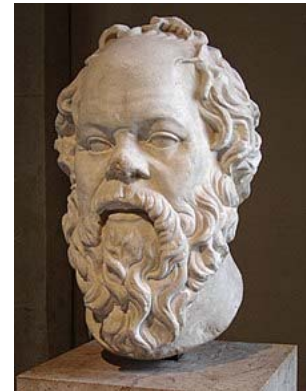

Socratic Questions for Guided Discovery

- What is the effect of telling myself this thought?
- What could be the effect of changing my thinking?
- What would I tell someone else if he/she viewed this situation in this way?
- What should I do now?

DISTRESS TOLERANCE

What is Acceptance?

- Acknowledgment of the facts of a situation and realistic limitations
- Does not mean approval, resignation, or passivity
- Is not anti-change: it is a prerequisite for change!
- Similar to the Serenity Prayer
 - Serenity** to accept what I cannot change
 - Courage** to change the things I can
 - Wisdom** to know the difference
- Usually involves sadness or grief

Wise Mind **ACCEPTS**

Distracting with...

Activities—engage in any tolerable exercise

Contributing—give something to another

Comparisons—compare self to others the same or less fortunate than you

Emotions—do things that stimulate different emotions,

Pushing away—leave the situation (mentally) for awhile

Thoughts—count, focus attention elsewhere

Sensations—hold ice, squeeze ball, etc.

Emotion Regulation

Healthy Lifestyle

Eating

Exercise

Sleep



Sleep Hygiene

- Avoid Caffeine, Alcohol, Nicotine, and Other Chemicals that Interfere with Sleep
- Lighten Up on Evening Meals
- Exercise helps promote restful sleep if it is done several hours before you go to bed.

Sleep Hygiene

- Go to bed the same time every night. ...
- Get up at the same time every morning (7 days/week)
- A quiet place to sleep. ...
- Keep your bedroom dark and cool. ...
- Dedicate your bed to sleep and sex, and nothing else. ...
- Turn off all screens 30 minutes before bed
- Turn phone off
- Limit your daytime naps

Activity Monitoring & Planning

Activity Monitoring

- Assess how patients spend their time.
- How do their prior beliefs about their activity levels compare with the actual measures?
- How well did they do certain activities compared to their actual performance?
- How much pleasure did they experiences when engaged in activities compared with what they expected?

Activity Monitoring

- **Monitoring**
 - Track activities over the week
 - Rate mood
 - Review to notice patterns, high-risk times/situations, relationship between mood and activities

Activity Planning

- **Scheduling**
 - Plan for the week ahead, scheduling health activities
 - Plan new activities to fill time voids
 - Maximize activities that create a sense of **mastery and accomplishment.**
 - Utilize activities that involve **enjoyment**
 - Review/troubleshoot

Breathing and Mindfulness

Benefits of Relaxation

- Helpful in managing stress
- Helpful in managing depression and anxiety
- May help to retrain the brain to respond thoughtfully to stress, rather than reacting impulsively
- Helpful to people maintain gains

One Minute Breathing Exercise

- Breathe in deeply through your nose (Four seconds)
- Fill lungs with air—hold for a few seconds (Two seconds)
- Exhale slowly through your mouth (Six seconds)
- Repeat four times

Mindfulness

- Definition: “Paying attention in a particular way, on purpose, in the present moment, non-judgmentally” (Kabat-Zinn, 1995)
- Core component of ACT, MBCT, and DBT and other Mindfulness or Acceptance-based approaches

Mindfulness: What is it?

- Training in Attentional control (e.g. focusing exercises)
- Observing facts vs interpretations
- Non-Judgmental Stance
- Acknowledgment/Acceptance of what is
- The opposite of multi-tasking
- Can be used with positive and negative emotions: helps us experience positive emotions more fully and navigate negative emotions more skillfully
- Can bring mindfulness to any activity

Cognitive Defusion Exercise

- “Leaves on a Stream” provides an excellent cognitive defusion exercise used in Acceptance & Commitment Therapy:
- (1) Sit in a comfortable position and either close your eyes or rest them gently on a fixed spot in the room.
- (2) Visualize yourself sitting beside a gently flowing stream with leaves floating along the surface of the water. Pause 10 seconds.
- (3) For the next few minutes, take each thought that enters your mind and place it on a leaf... let it float by. Do this with each thought – pleasurable, painful, or neutral. Even if you have joyous or enthusiastic thoughts, place them on a leaf and let them float by.
- (4) If your thoughts momentarily stop, continue to watch the stream. Sooner or later, your thoughts will start up again. Pause 20 seconds.
- (5) Allow the stream to flow at its own pace. Don’t try to speed it up and rush your thoughts along. You’re not trying to rush the leaves along or “get rid” of your thoughts. You are allowing them to come and go at their own pace.

Cognitive Defusion Exercise Russ Harris (2009)

Cognitive Defusion Exercise (continued)

- (6) If your mind says “This is dumb,” “I’m bored,” or “I’m not doing this right” place those thoughts on leaves, too, and let them pass. Pause 20 seconds.
- (7) If a leaf gets stuck, allow it to hang around until it’s ready to float by. If the thought comes up again, watch it float by another time. Pause 20 seconds.
- (8) If a difficult or painful feeling arises, simply acknowledge it. Say to yourself, “I notice myself having a feeling of boredom/impatience/frustration.” Place those thoughts on leaves and allow them float along.
- (9) From time to time, your thoughts may hook you and distract you from being fully present in this exercise. This is normal. As soon as you realize that you have become sidetracked, gently bring your attention back to the visualization exercise

INTERPERSONAL EFFECTIVENESS

Interpersonal Effectiveness

- Obtaining your legitimate rights
- Refusing unwanted or unreasonable requests
- Resolving interpersonal conflict
- “DEAR MAN”

“DEAR MAN”

- **Describe**— the situation
- **Express**—feelings and opinions about the situation
- **Assert**—by asking for what you want and saying “no” to what you don’t want
- **Reinforce**—the other person in advance

- **Mindful**—stay focused on your objectives
- **Appear Confident**—includes tone of voice, eye contact, posture, etc
- **Negotiate**—be willing to give to get

Dialectic Behavior Therapy, Marsha Linehan, 1993

CBT-Hopelessness

Safety Plan

- Warning signs
- Internal coping strategies: Things I can do on my own to take my mind off my problems
- People and social settings that provide distraction
- People whom I can ask for help
- Professionals I can contact during a crisis
- Making the environment safe

Stanley & Brown, 2008)

Hope Box

- Letters or printed emails that mean a lot to you
- Photos of special times you have had – or of special times you hope to have
- Photos of loved ones
- Inspirational quotes
- Spiritual or religious verses
- Articles or columns that you find meaningful
- Jokes that make you laugh
- Anything else that reminds you of reasons to stay alive

<https://www.speakingofsuicide.com/2013/05/16/hope-box/>

Action Plans

Action Plan: Rationale

- A way of encouraging clients to practice new skills between session.
- “Based on what we discussed today, what is something you would like to work on this week?”

Common Action Plan Exercises

- Implement a coping skill to manage stress
- Evaluate thought-looking for evidence
- Use a coping card.
- Complete an activity log.
- Practice controlled breathing/mindfulness
- Call a family member or friend.
- Use communication skills.
- Implement a decision

Generating Action Plans

- Tailor homework to the individual client.
- Provide a rationale.
- Design the assignment collaboratively.
- Consider starting the assignment in session.
- Discuss a plan for completing the assignment (e.g., where, when, visual prompts or reminders).
- Anticipate problems.

Coping Cards

Three Types:

- Automatic Thought-Adaptive Response
- Coping strategies
- Reminder-Why I am doing this (values)

Imagery Directions

- Pick an appropriate time in the future: (e.g. days, years, situation)
- Clearly state what you want to have happen at that time/situation (e.g. demonstrate a skill, experience a feeling, achieve a goal)
- Using all five senses, imagine yourself in the future situation as if it were happening right now (i.e. what do you see, hear, feel, smell, taste?)

Imagery

- Imagine yourself performing the skill/having your desired experience in the way you realistically hope to perform.
- Completely perform the skill/experience through to the end and beyond
- Process how well the imagery process went and discuss whether it needs to be tweaked.

BEHAVIORAL EXPERIMENTS

Purpose of Behavioral Experiments

- Evaluating thoughts and beliefs through experience
- Tends to be more powerful than standard cognitive restructuring
- Helpful when clients “understand intellectually” but “feel like it’s true”

Behavioral Experiments

“The therapist helps the client identify a specific cognition that the client needs to test, and then uses activity as a way of testing, and usually disconfirming, the hypothesis.”

Keeping in mind the case formulation, collaboratively design behavioral experiments so that the client can test the cognition.

Behavioral Experiments

- Step 1: Present the Rationale
- Step 2: Develop a prediction
- Step 3: Set up the detailed experiment (with coping plans for feared outcomes)
- Step 4: Record the Outcome
- Step 5: Review the outcome and summarize

Assess Likelihood of Completion

- On a scale of 0-100% how likely is it that you will complete the Plan?
- Anything less than 90% is in the questionable category
- Redesign Plan until you receive a “90%” response

Summary

- The Situation
- Values clarification
- CBT Model
- Cognitive Conceptualization
 - Depression
 - Anxiety
 - Anger
- Cost-Benefit Analysis
- Socratic Questions
- Distress Tolerance
- Emotional Regulation
- Sleep Hygiene
- Activity Monitoring and Planning
- Breathing and Mindfulness
- Interpersonal Effectiveness
- CBT_Hopelessness
- Action Plans
 - Coping Cards
 - Imagery
 - Behavioral Experiments

CBT Training through Beck Institute

- Workshops in Philadelphia
- Training for Organizations (at your location)
- Supervision
- Consultation
- Online Training (www.beckcbtonline.org)
- Live, interactive webinars

For more information email education@beckinstitute.org

Beck Institute CBT Certification

Get Beck Certified!

Learn more at

<https://beckinstitute.org/certification/>

Join the CBT Conversation

beckinstitute.org

Sign up for the Beck Institute newsletter

beckinstitute.org/subscribe



Get social with Beck Institute on its social channels



[/beck-institute-for-cognitive-behavior-therapy/](https://www.linkedin.com/company/beck-institute-for-cognitive-behavior-therapy/)



[@beckinstitute](https://www.facebook.com/beckinstitute) (Facebook)



[@BeckInstitute](https://twitter.com/BeckInstitute) (Twitter)



[youtube.com/BeckInstitute](https://www.youtube.com/BeckInstitute)

