



Grain Bucket Elevator Capacity Increased by 75%



Ray-Carroll County Grain Growers in Carrollton, MO
Photo Credit @ www.ray-carroll.com

Challenge

Ray-Carroll County Grain Growers, 2.8-million bushel country elevator in Carrollton, MO needed to increase receiving capacity in order to better accommodate its growing customer base. The challenge was to upgrade the receiving system without shutting down operations. Twenty million bushels of corn are received at this facility every year.

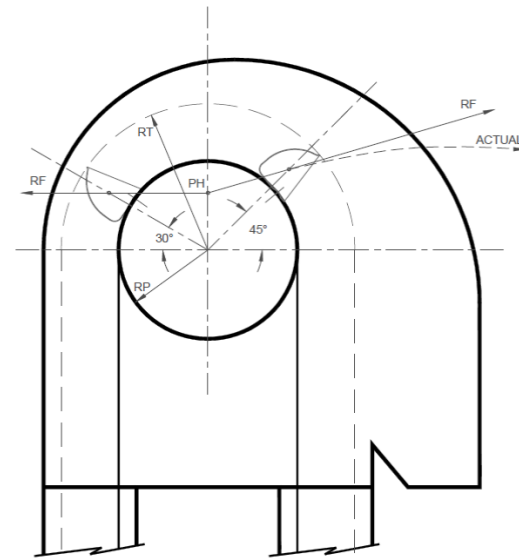
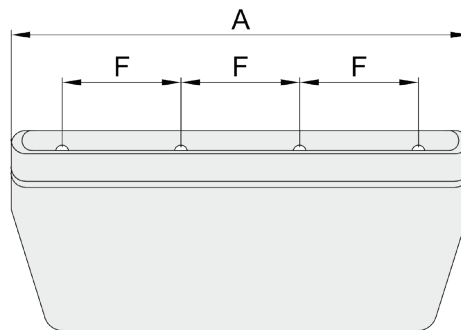
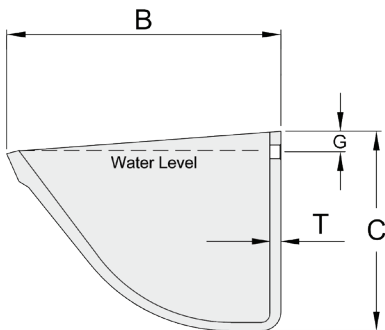

Solution

4B Components engineering group analyzed the existing elevator legs and designed an improved solution. 4B JUMBO™ CC-S® 16x8 low-profile buckets were installed and spaced 7.75 inches apart. The low-profile design allowed Ray-Carroll to install the buckets closer together resulting in the ability to add 224 additional buckets per leg. To handle the increased load of the additional buckets, 18 inch wide 1,000-PIW (pounds per inch of belt width) rubber belting was installed utilizing 4B BC belt splice clamps, designed for heavy weight belts.



4B JUMBO™ CC-S® 16x8 low-profile buckets, 4B Braime Clamps & 1,000-piw rubber belting installed

UPGRADE SUMMARY

MATERIAL - Wet Corn @ 48 Pounds per Cubic Foot
DESIGN CAPACITY - 15,000 Bushels per Hour
DISCHARGE HEIGHT - 196.5'
HEAD PULLEY - 42" Dia. x 20" Wide CF Drum Style
BOOT PULLEY - 42" Dia. x 20" Wide CF Wing Style
BELT SPEED - 653 Feet per Minute
BELTING - 18" x 414' x 5/1000 PIW SOR-SC-FR
BUCKETS - Jumbo CC-S 16x8 Low Profile Vent #3
BUCKET SPACING - 7.75"
BUCKET CAPACITY (Water Level) - 522 Cubic Inches
HARDWARE - Fang Bolts 5/16" x 1-3/4"
SPLICE - 4B Segmented BC1 Clamp
MOTOR - 150HP
HEAD SHAFT - 4-15/16" Diameter
BOOT SHAFT - 2-15/16" Diameter

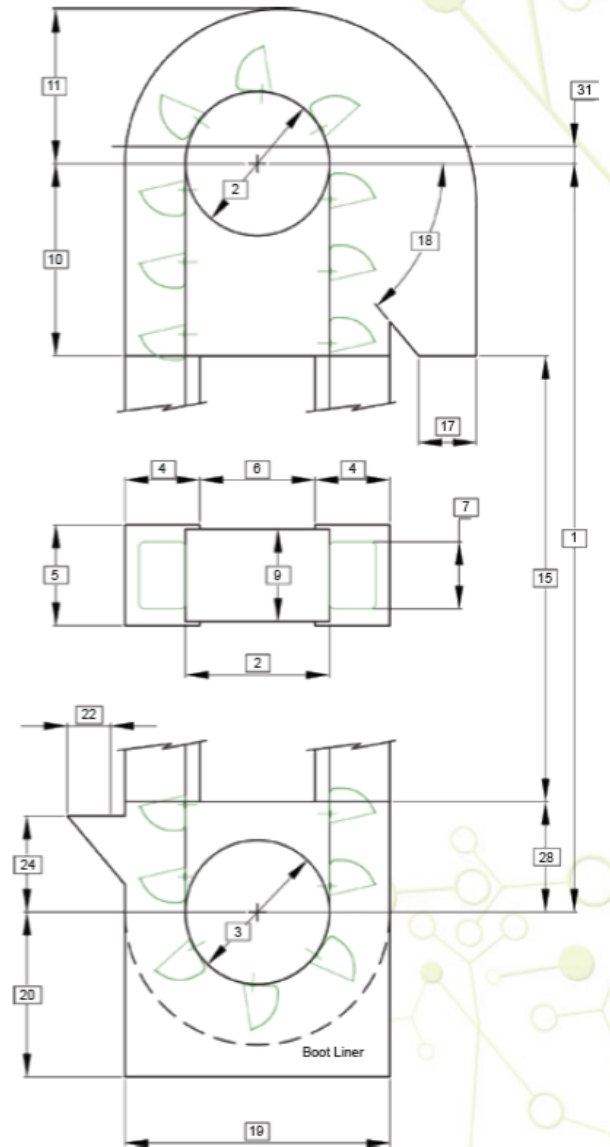

Results

It took two days for the millwright team to install the new buckets on the two legs. By working on one leg at a time, the other remained operational, and the elevator was able to receive grain throughout the process. Before the upgrades, the two legs each ran at 8,500 bph capacity. Now, each leg can handle 15,000 bph, an increase of approximately 75% throughput.

Ray-Carroll was very pleased with the solution provided by the 4B engineering team. They increased capacity and by the installation of the 4B JUMBO™ CC-S® 16x8 low-profile buckets they achieved their goal of making it easier and quicker for their customers to deliver grain. Trucks now go scale to scale in under four minutes.

It's Time to Wake the Animal

STRONG • EFFICIENT • SMART



4B JUMBO™ CC-S®
16X8 LOW-PROFILE BUCKETS



HEAVY DUTY
RUBBER BELTING

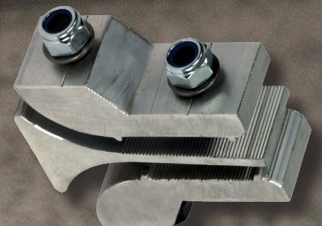

4B BRAIME CLAMP (BC)



4B Components Ltd.

www.go4b.com/usa

BETTER BY DESIGN