

MEDICAL/DENTAL OFFICE SPACE

FOR LEASE

15835 Pomerado Road
Poway, CA 92064



RON GRAVES
Coldwell Banker Commercial SC
858.822.9215
RonG@CBCsocalgroup.com
CalDRE # 00521968

TODD D. FORTNEY
Coldwell Banker Brokerage
619.518.1783
Todd@ToddFortney.com
CalDRE # 01258197

404 Camino Del Rio, Suite 510 | San Diego, CA 92108
P: 858-300-6777 | F: 951-239-3147
CalDRE: 02089395 | www.cbcsocalgroup.com



MEDICAL/DENTAL OFFICE SPACE

15835 Pomerado Road
Poway, CA 92064

FOR LEASE

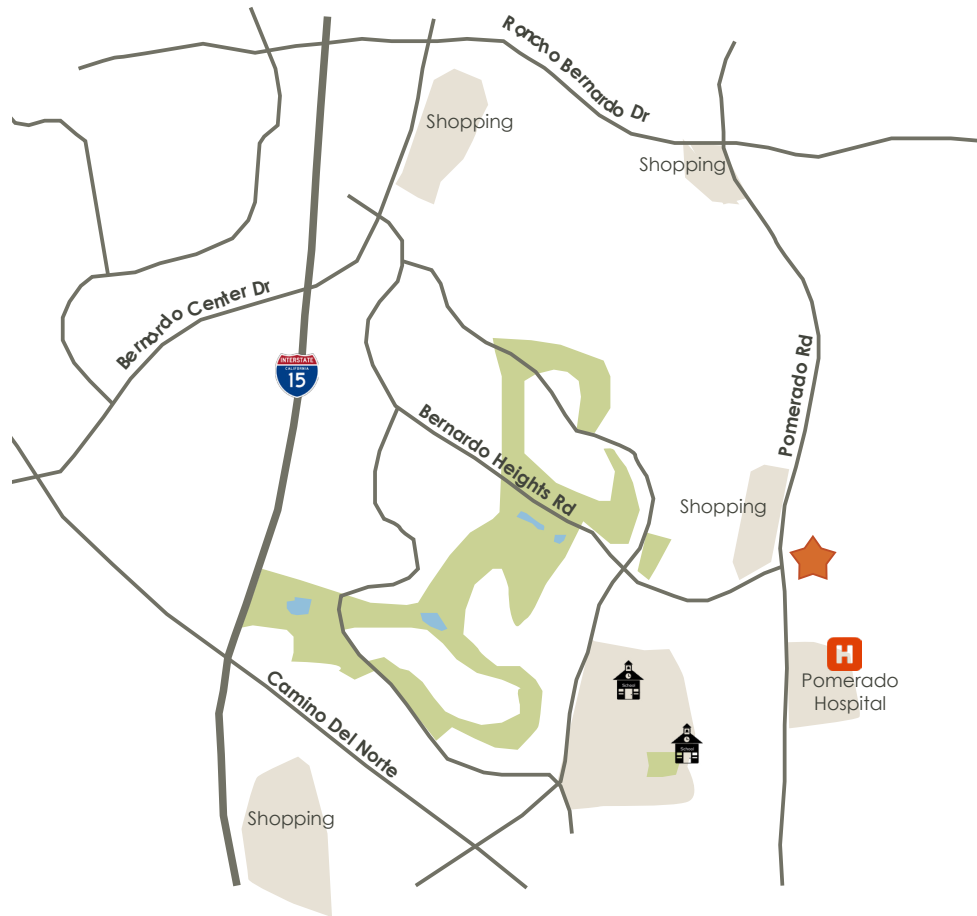

PROPERTY HIGHLIGHTS

- **Lease Rate: Negotiable**
- Near Pomerado Hospital
- High Income Area
- Nearby Shopping
- Located at Bernardo Heights Road and Pomerado Road
- Signalized Corner
- Minutes From the I-15 Freeway

RON GRAVES
Coldwell Banker Commercial SC
858.822.9215
RonG@CBCsocalgroup.com
CalDRE # 00521968

TODD D. FORTNEY
Coldwell Banker Brokerage
619.518.1783
Todd@ToddFortney.com
CalDRE # 01258197

404 Camino Del Rio, Suite 510 | San Diego, CA 92108
P: 858-300-6777 | F: 951-239-3147
CalDRE: 02089395 | www.cbcsocalgroup.com



MEDICAL/DENTAL OFFICE SPACE

FOR LEASE

15835 Pomerado Road
Poway, CA 92064

AVAILABILITY

SUITE	RSF	RENTAL RATE
102	±1,047	Negotiable



Suite 102 Floorplan

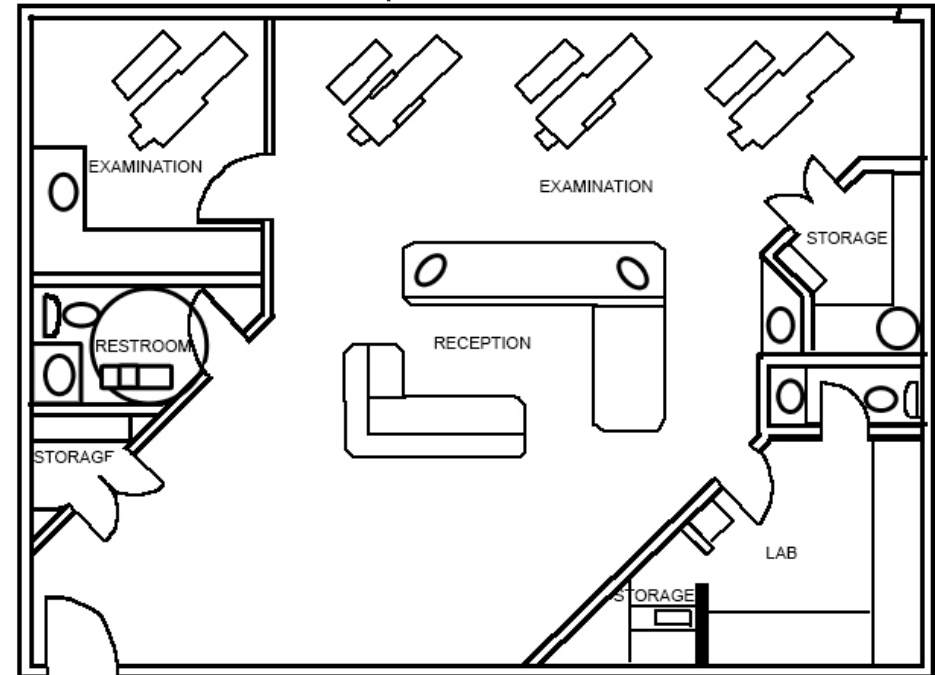

- Reception & waiting area
- Large exam areas
- Storage
- Lab Space

RON GRAVES
Coldwell Banker Commercial SC
858.822.9215
RonG@CBCsocalgroup.com
CalDRE # 00521968

TODD D. FORTNEY
Coldwell Banker Brokerage
619.518.1783
Todd@ToddFortney.com
CalDRE # 01258197

404 Camino Del Rio, Suite 510 | San Diego, CA 92108
P: 858-300-6777 | F: 951-239-3147
CalDRE: 02089395 | www.cbcsocalgroup.com



MEDICAL/DENTAL OFFICE SPACE

FOR LEASE

15835 Pomerado Road
Poway, CA 92064

AVAILABILITY

SUITE	RSF	RENTAL RATE
402	±1,670	Negotiable

- Waiting and Reception areas
- Private office
- Operating Rooms
- Lounge

Suite 402 Floorplan

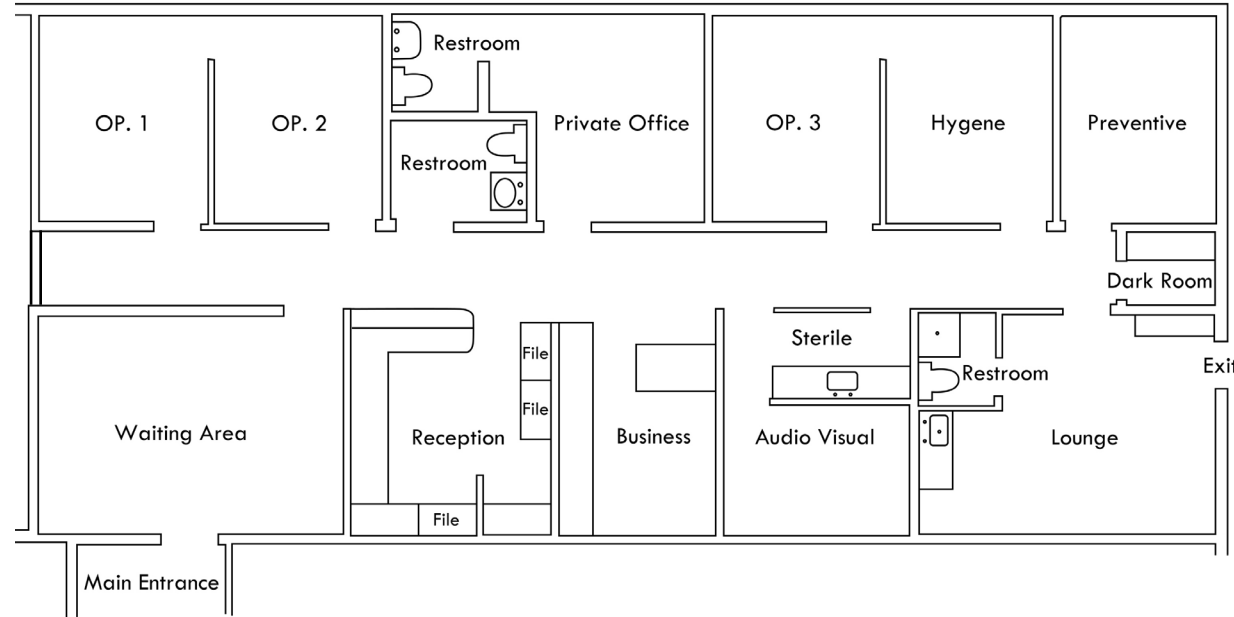

RON GRAVES
Coldwell Banker Commercial SC
858.822.9215
RonG@CBCsocalgroup.com
CalDRE # 00521968

TODD D. FORTNEY
Coldwell Banker Brokerage
619.518.1783
Todd@ToddFortney.com
CalDRE # 01258197

404 Camino Del Rio, Suite 510 | San Diego, CA 92108
P: 858-300-6777 | F: 951-239-3147
CalDRE: 02089395 | www.cbcsocalgroup.com



MEDICAL/DENTAL OFFICE SPACE

FOR LEASE

15835 Pomerado Road
Poway, CA 92064

AVAILABILITY

SUITE	RSF	RENTAL RATE
403	±1,467	Negotiable

- Reception & waiting areas
- Private offices
- Storage
- Lab Space

Suite 403 Floorplan

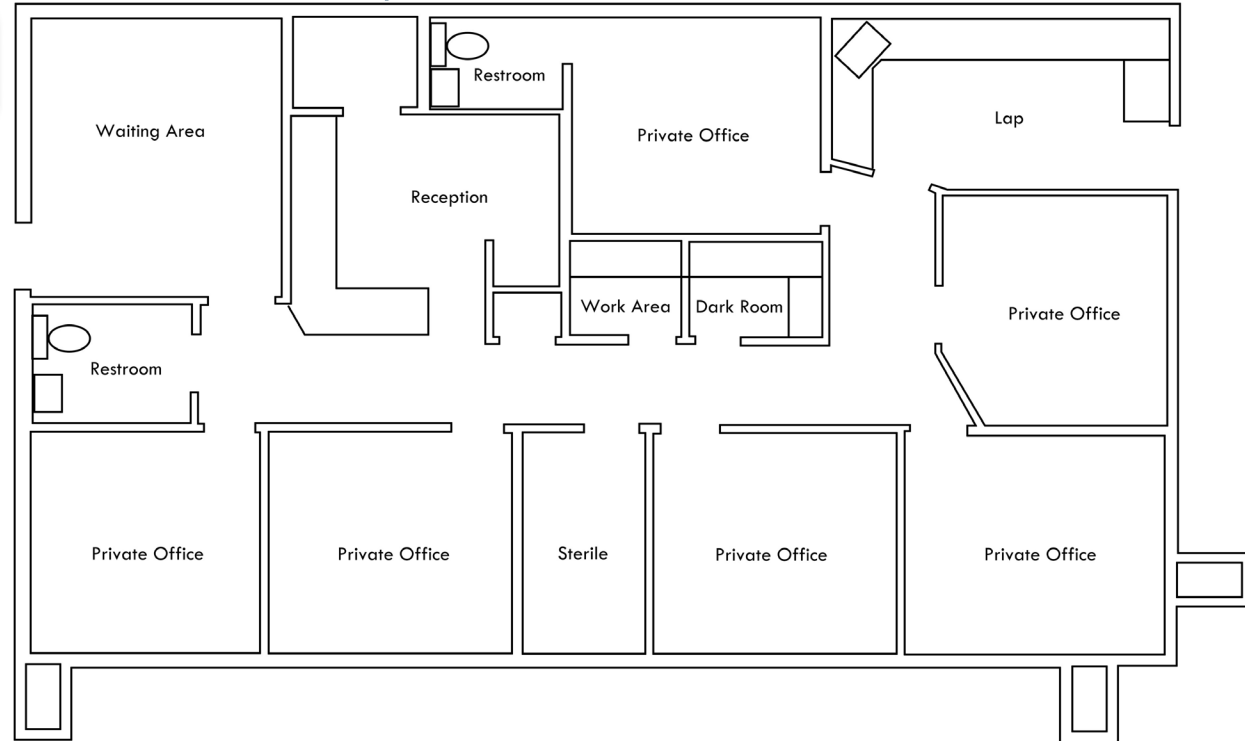

RON GRAVES
Coldwell Banker Commercial SC
858.822.9215
RonG@CBCsocalgroup.com
CalDRE # 00521968

TODD D. FORTNEY
Coldwell Banker Brokerage
619.518.1783
Todd@ToddFortney.com
CalDRE # 01258197

404 Camino Del Rio, Suite 510 | San Diego, CA 92108
P: 858-300-6777 | F: 951-239-3147
CalDRE: 02089395 | www.cbcsocalgroup.com



MEDICAL/DENTAL OFFICE SPACE

FOR LEASE

15835 Pomerado Road
Poway, CA 92064

LOCATION

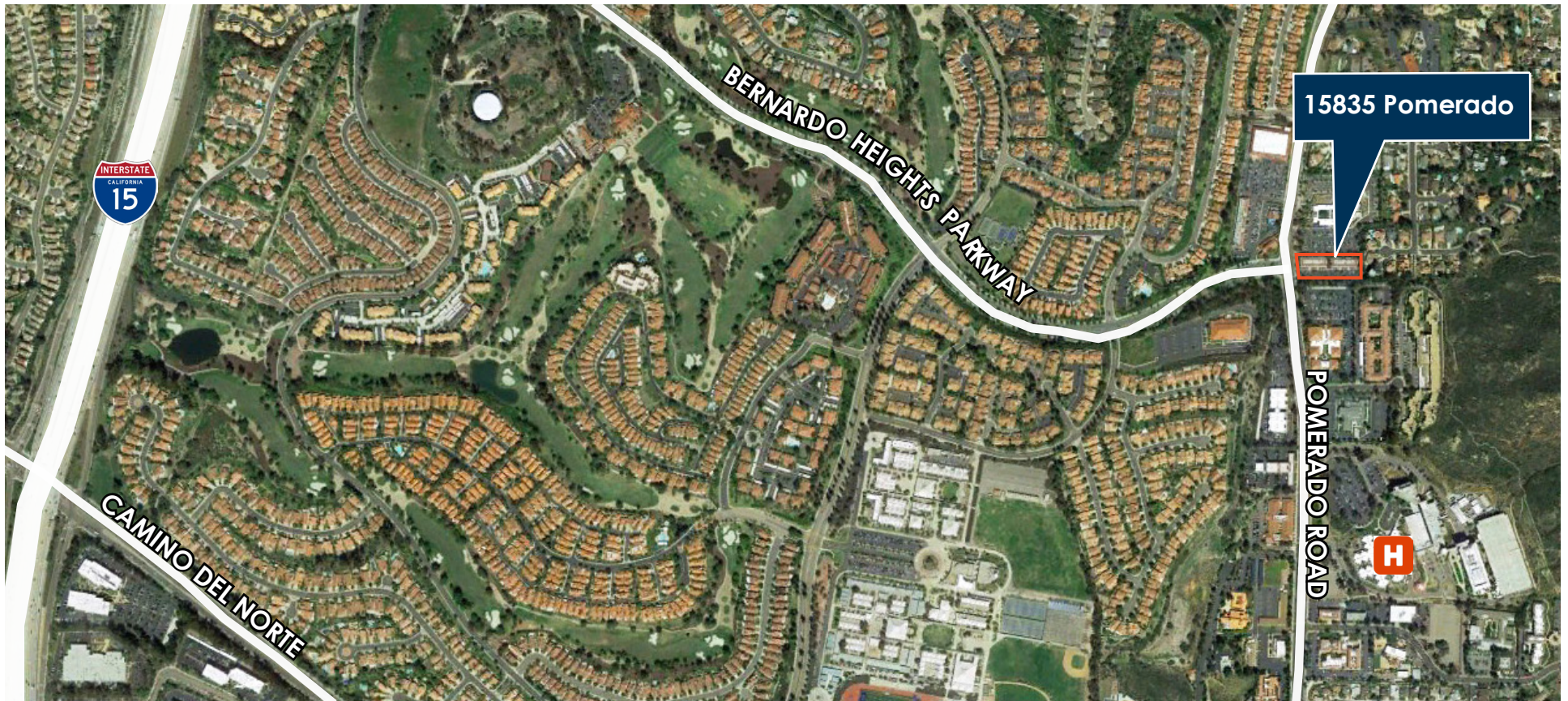

RON GRAVES
Coldwell Banker Commercial SC
858.822.9215
RonG@CBCsocalgroup.com
CalDRE # 00521968

TODD D. FORTNEY
Coldwell Banker Brokerage
619.518.1783
Todd@ToddFortney.com
CalDRE # 01258197

404 Camino Del Rio, Suite 510 | San Diego, CA 92108
P: 858-300-6777 | F: 951-239-3147
CalDRE: 02089395 | www.cbcsocalgroup.com

