

# **Policies & Procedures Updates**

**January 2024**



## Clinical Advisory Council Monthly Consent Agenda Summary

Committee: Policy and Procedures Committee

Date: January 2, 2023

### Accomplishments:

Passed 3 new policies or procedures

Passed 14 renewed policies or procedures

Passed 1 retired policies or procedures

### Action Plan Updates:

#### New Policies or Procedures approved by Policy and Procedures Committee:

##### Information Technology

1. IT-018-SOP-001 Workstation Use NEW

##### Medical

2. MED-049 Provider Off-boarding Workflow NEW

##### Nursing

3. NUR-024-SOP-SO-053 Standing Order for POCT UDS - NEW

#### Policies or Procedures Submitted for Renewal:

##### Administration

1. ADM-026 Breast or Cervical Cancer Treatment Funds Request REV1-2024

##### Clinical Operations

2. COP-035 Depression Screening REV12-2023

##### Facilities

3. FAC-400-SOP-421 Adjustable Workstation (Stand Desks and Chairs) REV12-2023

##### Health Information Management

4. HIM-002-SOP-ROI-018 Exporting Patient Data from Galen into EPIC's ROI Template (Export Chart vs Build an Export) REV12-2023
5. HIM-002-SOP-ROI-019 Exporting and Viewing a Single Report in Galen REV12-2023
6. HIM-002-SOP-ROI-020 Completing a Release of Information Request for Dental Reports and Imaging REV12-2023
7. HIM-006-SOP-OM-006 Operating Neopost Bulk Mailing Machine REV12-2023
8. HIM-008-SOP-DI-001 Marking a Patient for a Potential Merge REV12-2023

**Nursing**

9. NUR-017-SOP-LS-001 Laboratory Specimen Labeling REV1-2024
10. NUR-024-SOP-SO-041-A Standing Order for Comirnaty COVID-19 Vaccine Administration for 12 Years of Age and Older REV1-2024

**Patient Communications**

11. PCM-105-SOP-001 OB-GYN Appointment Scheduling REV12-2023

**Pharmacy**

12. PHM-023-SOP-340B-003 Patient Definition REV12-2023
13. PHM-023-SOP-340B-010 Referrals REV12-2023
14. PHM-028-REMS-Drugs-SOP-001 Dispensing Esketamine (Spravato) REV12-2023

**Retired Policies or Procedures:**

1. NUR-024-SOP-SO-038 SO for SARS-COVID-19 Testing via Sofia 2 Analyzer for Symptomatic ERH Employees and Sis RETIRED

# January 2024 Policies & Procedures

## New P&P's and Summary of Changes to Current P&Ps

*In this document, "major" is subjective. Syntactical changes are not considered "major changes" and may or may not be highlighted.*

### NEW POLICIES & PROCEDURES

#### IT-018-SOP-001 Workstation Use NEW

- This plan provides a procedure for proper use of a workstation per the Workstation Use Policy.

#### MED-049 Provider Off-boarding Workflow NEW

- To establish a written guideline of all activities required to properly off-board clinical providers, to avoid delays in care, poor patient care experiences, or data information / access challenges. To provide complete and timely information to all internal and external , and to provide adequate notification to all required departments and individuals.

#### NUR-024-SOP-SO-053 Standing Order for POCT UDS - NEW

- This standing order allows nurses and medical assistants to perform a urine drug screen (UDS) on patients who are participating in the medication assistance treatment (MAT) program and patients being treated by a medical provider for substance abuse.

### RENEWED POLICIES & PROCEDURES

#### ADM-026 Breast or Cervical Cancer Treatment Funds Request REV1-2024

- Remove attached and see **highlights**.

#### COP-035 Depression Screening REV12-2023

- Updated titles of staff.

#### FAC-400-SOP-421 Adjustable Workstation (Stand Desks and Chairs) REV12-2023

- See **highlights**.

#### HIM-002-SOP-ROI-018 Exporting Patient Data from Galen into EPIC's ROI Template (Export Chart vs Build an Export) REV12-2023

- How Galen (EHR) functions with EPIC (EHR) in pulling information into the ROI templates. Galen houses older EHRs from NextGen and EPIC houses newer EHRs but in HIM we can process the releases for both using these steps. This is a renewal with up-to-date screen shots / information. Hence, the reference to NextGen.

**HIM-002-SOP-ROI-019 Exporting and Viewing a Single Report in Galen REV12-2023**

- How Galen (EHR) functions with EPIC (EHR) in pulling information into the ROI templates. Galen houses older EHRs from NextGen and EPIC houses newer EHRs but in HIM we can process the releases for both using these steps. This is a renewal with up-to-date screen shots / information. Hence, the reference to NextGen.

**HIM-002-SOP-ROI-020 Completing a Release of Information Request for Dental Reports and Imaging REV12-2023**

- Changes to the order; the newest addition to the Dental ROI SOP; allow HIM to provide images outside of the PDF format to requesters.

**HIM-006-SOP-OM-006 Operating Neopost Bulk Mailing Machine REV12-2023**

- See **highlights**.

**HIM-008-SOP-DI-001 Marking a Patient for a Potential Merge REV12-2023**

- Minor changes of updated screen shots. The one major change since the EPIC upgrade is step one (snip attached). Workflow remains the same.

**NUR-017-SOP-LS-001 Laboratory Specimen Labeling REV1-2024**

- See **highlights**.

**NUR-024-SOP-SO-041-A Standing Order for Comirnaty COVID-19 Vaccine Administration for 12 Years of Age and Older REV1-2024**

- Updated the Purpose Statement to include: This standing order allows licensed nursing staff and medical assistants to order and vaccinate both established and non-established individuals who are 12 years of age and older and who meet the criteria below with the COMIRNATY (COVID-19 Vaccine, mRNA) (2023-2024 Formula).
- On pages 3-8, updated information regarding how the vaccine is available as a single dose prefilled glass syringe, single dose prefilled plastic syringe or single dose vial. Information includes NDC numbers, supply/storage, preparation, and administration for each vaccine form available.
- On pages 10-11, updated Table 1: CDC Recommended COVID-19 vaccination schedule for people who are moderately or severely immunocompromised by COVID-19 vaccination history.

**PCM-105-SOP-001 OB-GYN Appointment Scheduling REV12-2023**

- See **strikethroughs** and **highlights**.

**PHM-023-SOP-340B-003 Patient Definition REV12-2023**

- Updated our 340B patient policies based on recent court rulings.

**PHM-023-SOP-340B-010 Referrals REV12-2023**

- Updated our 340B patient policies based on recent court rulings.

**PHM-028-REMS-Drugs-SOP-001 Dispensing Esketamine (Spravato) REV12-2023**

- No changes noted.

**RETIRED POLICIES OR PROCEDURES**

**NUR-024-SOP-SO-038 SO for SARS-COVID-19 Testing via Sofia 2 Analyzer for Symptomatic ERH Employees and Sis**

- This standing order will be retired since this testing is no longer done in the clinics.

# EL RIO HEALTH

**SCOPE:**

This Procedure applies to **CLINICAL** and **NON-CLINICAL** departments in the following El Rio Health functional areas and/or locations (check all that apply):

- |   |   |  |   |
|---|---|--|---|
| <input checked="" type="checkbox"/> Family Medicine   | <input checked="" type="checkbox"/> Same Day Appt. Clinic | <input checked="" type="checkbox"/> Radiology              | <input checked="" type="checkbox"/> MOR/DOS         |
| <input checked="" type="checkbox"/> Internal Medicine | <input checked="" type="checkbox"/> HOB/HOU               | <input checked="" type="checkbox"/> Pharmacy               | <input checked="" type="checkbox"/> Administration  |
| <input checked="" type="checkbox"/> Pediatrics        | <input checked="" type="checkbox"/> SIA                   | <input checked="" type="checkbox"/> Laboratory             | <input checked="" type="checkbox"/> Human Resources |
| <input checked="" type="checkbox"/> Dental            | <input checked="" type="checkbox"/> Care Coordination     | <input checked="" type="checkbox"/> HIM                    | <input checked="" type="checkbox"/> Accounting      |
| <input checked="" type="checkbox"/> Behavioral Health | <input checked="" type="checkbox"/> Wellness              | <input checked="" type="checkbox"/> Information Technology | <input checked="" type="checkbox"/> Business Office |
| <input checked="" type="checkbox"/> Midwives          | <input checked="" type="checkbox"/> Clinical Pharmacy     | <input checked="" type="checkbox"/> Patient Communications | <input checked="" type="checkbox"/> Coding          |
| <input checked="" type="checkbox"/> OB/GYN            | <input checked="" type="checkbox"/> Facilities            | <input checked="" type="checkbox"/> Advocacy & Eligibility | <input checked="" type="checkbox"/> Security        |
| <input checked="" type="checkbox"/> Referrals         | <input checked="" type="checkbox"/> Purchasing            | <input checked="" type="checkbox"/> Physical Therapy       | <input checked="" type="checkbox"/> Transportation  |

<p><b>PROCEDURE DESCRIPTION:</b> Proper Use of El Rio Health Workstations</p>	<p><b>PAGE:</b> 1 of 2</p>
	<p><b>REFERENCE NUMBER:</b> IT-018-SOP-001</p>
<p><b>APPROVAL DATE:</b></p>	<p><b>DATES REVIEWED WITHOUT CHANGE:</b></p>
<p><b>EFFECTIVE DATE:</b></p>	<p><b>REPLACES PROCEDURE DATED:</b> <b>NEW</b></p>
<p><b>NEXT REVIEW DATE:</b></p>	<p><b>DATE RETIRED:</b> N/A</p>
<p><b>RESPONSIBILITY:</b> Chief Information Officer</p>	<p><b>APPROVALS:</b> PPC: CAC:</p>

**PURPOSE:**

This plan provides a procedure for proper use of a workstation per the Workstation Use Policy.

**DEFINITIONS:**

- El Rio Health Computer - Includes workstations, laptops, and other mobile devices provided by El Rio Health.
- Computer - denotes any El Rio Health approved electronic computing device.

**PROCEDURE:**

- El Rio Health computers are used to conduct the business of El Rio Health in a professional and legal manner.
- Members of the El Rio Health workforce and other users of workstations and computer systems that access, store, process, receive, or transmit ePHI, must comply with El Rio Health’s policies concerning access to its computing, network, and information resources.
- El Rio Health may revoke any user’s privileges, including but not limited to, user accounts and access to secured areas, when it is deemed necessary to preserve the integrity, confidentiality, and availability of facilities, user services, and data.

# EL RIO HEALTH

<b>PROCEDURE DESCRIPTION:</b> Proper Use of El Rio Health Workstations	<b>REFERENCE NUMBER:</b> IT-018-SOP-001
<b>PAGE:</b> 2 of 2	<b>EFFECTIVE DATE:</b>

- El Rio Health computers may be used for occasional personal use during the workday as long as that use is legal, ethical, timely, and appropriate. (At no time is there an assumption of privacy when using an El Rio Health computer for personal use).
- Users must never alter an El Rio Health computer to include, but not limited to, downloading any unauthorized software, or changing any computer settings that causes harm to the computer or the El Rio Health network.
- El Rio Health computers are installed at all El Rio Health owned and operated locations by the IT department in accordance with Facilities policies and guidelines.
- El Rio Health IT will assess a business location to ensure there is suitable power and network connectivity to meet the business's need.
- El Rio Health computers that are used at home or outside the El Rio Network are provided by El Rio Health IT and are not to be modified.
- El Rio Health computers should be locked when not in use, whether at an El Rio Health location (office, cubicle, exam room, etc.), at home, or any location outside the El Rio Health network.
- It is the user's responsibility to always ensure the appropriate use of the computer and the protection of confidential company information as well as protected health information (PHI).
- All ePHI on any El Rio Health electronic device must be encrypted and the device must be protected from unauthorized use through the use of screen locks, passcodes, passwords, and / or pins, as appropriate.
- To appropriately manage information assets and enforce security policies, El Rio Health logs, reviews, and monitors access to data (ePHI and non-ePHI).

## REFERENCES:

### Workstation Use - § 164.310(b)

“Implement policies and procedures that specify the proper functions to be performed, the manner in which those functions are to be performed, and the physical attributes of the surroundings of a specific workstation or class of workstation that can access electronic protected health information.”

### POLICY: IT-018 Workstation Use

# EL RIO HEALTH

**SCOPE:**

This Procedure applies to **CLINICAL** and **NON-CLINICAL** departments in the following El Rio Health functional areas and/or locations (check all that apply):

- |  |  |   |  |
|--|--|---|--|
| <input type="checkbox"/> Family Medicine   | <input type="checkbox"/> Same Day Appt. Clinic | <input type="checkbox"/> Radiology              | <input type="checkbox"/> MOR/DOS         |
| <input type="checkbox"/> Internal Medicine | <input type="checkbox"/> HOB/HOU               | <input type="checkbox"/> Pharmacy               | <input type="checkbox"/> Administration  |
| <input type="checkbox"/> Pediatrics        | <input type="checkbox"/> SIA                   | <input type="checkbox"/> Laboratory             | <input type="checkbox"/> Human Resources |
| <input type="checkbox"/> Dental            | <input type="checkbox"/> Care Coordination     | <input type="checkbox"/> HIM                    | <input type="checkbox"/> Accounting      |
| <input type="checkbox"/> Behavioral Health | <input type="checkbox"/> Wellness              | <input type="checkbox"/> Information Technology | <input type="checkbox"/> Business Office |
| <input type="checkbox"/> Midwives          | <input type="checkbox"/> Clinical Pharmacy     | <input type="checkbox"/> Patient Communications | <input type="checkbox"/> Coding          |
| <input type="checkbox"/> OB/GYN            | <input type="checkbox"/> Facilities            | <input type="checkbox"/> Advocacy & Eligibility | <input type="checkbox"/> Security        |
| <input type="checkbox"/> Referrals         | <input type="checkbox"/> Purchasing            | <input type="checkbox"/> Physical Therapy       | <input type="checkbox"/> Transportation  |

**PROCEDURE DESCRIPTION:**

Clinical Provider Off-boarding Requirements

**PAGE:**

1 of 2

**REFERENCE NUMBER:**

MED-049

**APPROVAL DATE:**

**DATES REVIEWED WITHOUT CHANGE:**

**EFFECTIVE DATE:**

**REPLACES PROCEDURE DATED:**

**NEW**

**NEXT REVIEW DATE:**

**DATE RETIRED:**

N/A

**RESPONSIBILITY:**

Professional Staff Services Supervisor  
 Chief Clinical Officer  
 Clinical Directors  
 IT Supervisors

**APPROVALS:**

PPC:  
 CAC:

**PURPOSE:** To establish a written guideline of all activities required to properly off-board clinical providers, to avoid delays in care, poor patient care experiences, or data information / access challenges. To provide complete and timely information to all internal and external, and to provide adequate notification to all required departments and individuals.

**PROCEDURE:** The following off-boarding processes will be completed upon receiving notice of a provider's departure from El Rio Health, provided proper notice is given.

1. Three Months prior to departure:
  - a. Provider Notice of Separation is sent to email group via Professional Staff Services Department (Primary PSSO Recruitment Assistant, back-ups, or PSSO Supervisor and PSSO Recruiter).
  - b. Clinical Director will notify Credentialing Department via email regarding re-assignment of panel instructions.
  - c. Controlled substances list is generated and reviewed by Clinical Director and departing

# EL RIO HEALTH

<b>PROCEDURE DESCRIPTION:</b> Clinical Provider Off-boarding Requirements	<b>REFERENCE NUMBER:</b> MED-049
<b>PAGE:</b> 2 of 2	<b>EFFECTIVE DATE:</b>

provider.

- d. Standardized Provider Exit Letter Template is provided by PSSO Recruitment Assistant to Clinical Director or Chief Clinical Officer for review and approval. Final approved letter is sent to Quality Department for bulk patient mailing process upon approval prior to 30-days from provider departure date.
  - e. Clinical Director will run the empanelment report.
  - f. Dental Providers – Dental Director will develop a plan to complete treatments in progress and communicate with the dental team.
2. One Month prior to departure:
    - a. Clinical Director will run report on outstanding lab / diagnostic orders to anticipate if anything urgent needs direct attention.
  3. Two weeks prior to departure:
    - a. Dental providers – Dental Director will coordinate transfer of care for unfinished treatments in process.
  4. Final week prior to departure:
    - a. Equipment such as Laptops, cellphones, extra monitors, etc. will be returned to the Clinical Director.
    - b. Provider shall return Identification Badge to Clinical Director.
    - c. Clinical Director shall check Inbox items to ensure all items are completed. Remaining items will be brought to provider’s attention for resolution prior to departure.
    - d. Clinical Director will plan for potential time to close out patient charts, as needed.
    - e. Coordination for bulk Primary Care Provider (PCP) re-assignment, if necessary, will be communicated to Credentialing department and team.
  5. After departure:
    - a. Clinical Director will provide designated coverage for provider inbox.
    - b. Outstanding lab orders will be cancelled at 30 days.

IT Checklist (maintained by IT)

Human Resources:

1. Human Resources Designee will schedule an exit interview with departing provider, if requested by the provider.

**REFERENCES:**

# EL RIO HEALTH

**MSCOPE:**

This Standing Order applies to CLINICAL and NON-CLINICAL departments in the following El Rio Health functional areas and/or locations (check all that apply):

- |   |   |   |  |
|---|---|---|--|
| <input checked="" type="checkbox"/> Family Medicine   | <input checked="" type="checkbox"/> Same Day Appt. Clinic | <input type="checkbox"/> Radiology              | <input type="checkbox"/> MOR/DOS         |
| <input checked="" type="checkbox"/> Internal Medicine | <input checked="" type="checkbox"/> HOB/HOU               | <input type="checkbox"/> Pharmacy               | <input type="checkbox"/> Administration  |
| <input checked="" type="checkbox"/> Pediatrics        | <input checked="" type="checkbox"/> SIA                   | <input type="checkbox"/> Laboratory             | <input type="checkbox"/> Human Resources |
| <input type="checkbox"/> Dental                       | <input checked="" type="checkbox"/> Care Coordination     | <input type="checkbox"/> HIM                    | <input type="checkbox"/> Accounting      |
| <input checked="" type="checkbox"/> Behavioral Health | <input type="checkbox"/> Wellness                         | <input type="checkbox"/> Information Technology | <input type="checkbox"/> Business Office |
| <input checked="" type="checkbox"/> Midwives          | <input type="checkbox"/> Clinical Pharmacy                | <input type="checkbox"/> Patient Communications | <input type="checkbox"/> Coding          |
| <input checked="" type="checkbox"/> OB/GYN            | <input type="checkbox"/> Facilities                       | <input type="checkbox"/> Advocacy & Eligibility | <input type="checkbox"/> Security        |
| <input type="checkbox"/> Referrals                    | <input type="checkbox"/> Purchasing                       | <input type="checkbox"/> Physical Therapy       | <input type="checkbox"/> Transportation  |

**STANDING ORDER DESCRIPTION:**  
Standing Order for Performing a Point of Care Testing (POCT), Urine Drug Screen (UDS)

**PAGE:**  
1 of 2

**REFERENCE NUMBER:**  
NUR-024-SOP-SO-053

**APPROVAL DATE:**

**DATES REVIEWED WITHOUT CHANGE:**

**EFFECTIVE DATE:**

**REPLACES POLICY DATED:**  
**NEW**

**NEXT REVIEW DATE:**  
(ANNUAL)

**DATE RETIRED:**  
N/A

**RESPONSIBILITY:**  
Regional Health Center Directors  
Medical Directors

**APPROVALS:**  
PPC:  
CAC:

**Authorized by Chief Clinical Officer (CCO):**

**PURPOSE:** This standing order allows nurses and medical assistants to perform a urine drug screen (UDS) on patients who are participating in the medication assistance treatment (MAT) program and patients being treated by a medical provider for substance abuse.

**PROCEDURE:**

1. A POCT UDS is performed before an initial MAT injection and before subsequent injections per provider direction.
2. Under this standing order, nurses, and medical assistants, who have completed the competency with the procedure, may order the test. When ordering select **“Per protocol: no cosign required”** and add the appropriate authorizing provider.
3. Perform the test following established El Rio Health Laboratory point of care testing (POCT) procedures for testing the specimen and documenting the results.

# EL RIO HEALTH

<b>STANDING ORDER DESCRIPTION:</b> Standing Order for Performing a Point of Care Testing (POCT), Urine Drug Screen (UDS)	<b>REFERENCE NUMBER:</b> NUR-024-SOP-SO-053
<b>PAGE:</b> 2 of 2	<b>EFFECTIVE DATE:</b>

4. Notify the provider of the UDS results.
5. UDS results must be recorded in the patient's Electronic Health Record, and on the POCT UDS log.
6. The urine is then sent to the Lab for a confirmation test.

## REFERENCES:

NUR-015 Point of Care Testing Quality Assurance Policy

NUR-015-SOP-QC-002 Point of Care Testing (POCT)- Staff Competencies and General Ordering Procedure

NUR-031 Point of Care Testing (POCT), Urine Drug Screen Specimen Security and Chain of Custody

El Rio Lab Policy – iSCREEN Urine Test Dx Drug Screen Square Cup

Lippincott Procedure – POCT, Urine Drug Screen

# EL RIO HEALTH

**SCOPE:**

This policy applies to **CLINICAL** and **NON-CLINICAL** departments in the following El Rio Health functional areas and/or locations (check all that apply):

- |  |  |  |  |
|--|--|--|--|
| <input type="checkbox"/> Family Medicine   | <input type="checkbox"/> Same Day Appt. Clinic | <input type="checkbox"/> Radiology                         | <input type="checkbox"/> MOR/DOS                   |
| <input type="checkbox"/> Internal Medicine | <input type="checkbox"/> HOB/HOU               | <input type="checkbox"/> Pharmacy                          | <input checked="" type="checkbox"/> Administration |
| <input type="checkbox"/> Pediatrics        | <input type="checkbox"/> SIA                   | <input type="checkbox"/> Laboratory                        | <input type="checkbox"/> Human Resources           |
| <input type="checkbox"/> Dental            |  |  |  |
|  | <input type="checkbox"/> Care Coordination     | <input type="checkbox"/> HIM                               | <input type="checkbox"/> Accounting                |
| <input type="checkbox"/> Behavioral Health | <input type="checkbox"/> Wellness              | <input type="checkbox"/> Information Technology            | <input type="checkbox"/> Business Office           |
| <input type="checkbox"/> Midwives          |  | <input type="checkbox"/> Patient Communications            | <input type="checkbox"/> Coding                    |
| <input type="checkbox"/> OB/GYN            |  | <input checked="" type="checkbox"/> Advocacy & Eligibility | <input type="checkbox"/> Security                  |
| <input type="checkbox"/> Clinical Pharmacy |  | <input type="checkbox"/> Facilities/Materials              | <input type="checkbox"/> Transportation            |

**POLICY DESCRIPTION:**  
Cancer Treatment Funds Request

**PAGE:**  
1 of 5

**REFERENCE NUMBER:**  
ADM-026

**APPROVAL DATE:**

**DATES REVIEWED WITHOUT CHANGE:**

**EFFECTIVE DATE:**

**REPLACES POLICY DATED:**  
02/2019:04/2020

**NEXT REVIEW DATE:**

**DATE RETIRED:**  
N/A

**RESPONSIBILITY:**  
Foundation Executive Director  
Health Insurance and Community Resources  
Manager

**APPROVALS:**  
PPC:  
CAC:  
Board:

**POLICY:** It is the policy of El Rio Health to provide qualified El Rio Health patients and ~~women/men in~~ the community **members** with funding for treatment of Cancer through the assistance of the El Rio Health Foundation based on available budgeted funds.

**PROCEDURE:**

1. Individuals who have been diagnosed with cancer may request assistance or be referred by an El Rio Health provider / outside agency to the Community Health Supervisor who will review their case with the **Chief Clinical Operations Officer (CCOO)**.
2. Individuals will meet with El Rio Health Insurance team to assess eligibility for Arizona Health Care Cost Containment System (AHCCCS) as well as the Marketplace. If the patient is insured, the Eligibility Specialist will assess the insurance policy and the amount of the deductible.

## EL RIO HEALTH

<b>POLICY DESCRIPTION:</b> Cancer Treatment Funds Request	<b>REFERENCE NUMBER:</b> ADM-026
<b>PAGE:</b> 2 of 5	<b>EFFECTIVE DATE:</b>

3. If the individual is not eligible for AHCCCS or Marketplace or has a high deductible, they will meet with the Community Health Supervisor to proceed with enrolling them into the program.
4. The Community Health Supervisor will assess current referrals / oncology care plan as well as assure that both the primary care provider and specialty care providers are aware. Consideration will be given to specialists who currently have discounted agreements with El Rio Health. All clinical information will be reviewed by El Rio Health CCOO and the Executive Director, El Rio Foundation. The specialists must receive approval for the patient and amount approved.
5. Billing information on the approved individual for the program will be sent to the CCOO and Executive Director of El Rio Health Foundation by the Community Health Supervisor.
6. The approved amount of treatment funding for each individual will vary. The amount funded by the El Rio Health Foundation will not exceed \$15,000 for any individual. El Rio Health Foundation will submit approved payments from the oncologist / specialty provider and payment will be authorized from the restricted fund.
7. Community Health Supervisor will track overall requests and decisions. Refer to Attachment A for Tally of Patients log.

Community Health Supervisor will work with staff to track the number of people requesting help; those qualified and approved receiving support, the amount of funding per person, the number of people helped annually, their insurance status, and patient stories, if permission is granted. These program updates and stories will be shared with donors.

# EL RIO HEALTH

<b>POLICY DESCRIPTION:</b> Cancer Treatment Funds Request	<b>REFERENCE NUMBER:</b> ADM-026
<b>PAGE:</b> 3 of 5	<b>EFFECTIVE DATE:</b>

## Attachment A



### Cervical Cancer Program Foundation Fund Request Form

*This form must be submitted to Dr. Spigman for approval*

Date Requested:		Patient Name:	
DOB:		Patent ID:	
Financial Need:			
Name of Provider Requesting Funds:			
PCP Signature:			
Type of Treatment/Service:			
Appointment Date Requested:		Referral To:	
Community Health Advisor Name:		Location:	

Requirements
<p>Attach entire treatment plan; please indicate which procedures are to be covered by the foundation. Patient must sign the agreement form upon approval, and all documents must be scanned into the patient's chart.</p> <p><i>Patients may qualify for the foundation funds if they are uninsured or have a high deductible plan, and are unable to pay. The Chief Clinical Officer of El Rio Health must approve all applications.</i></p> <p style="text-align: center;"> <input type="checkbox"/> High Deductible      <input type="checkbox"/> Uninsured                 </p>

Approval/Denial		
<input type="checkbox"/> Approved	Date Approved:	Signature:
<input type="checkbox"/> Denied	Date Denied:	Reason For Denial

# EL RIO HEALTH

<b>POLICY DESCRIPTION:</b> Cancer Treatment Funds Request	<b>REFERENCE NUMBER:</b> ADM-026
<b>PAGE:</b> 4 of 5	<b>EFFECTIVE DATE:</b>

## Attachment **A**

### Tally of Patients Log

1	A	B	C	D	E	F	G	H	I	J	K
		Patient Name	DOB	Patient ID	Date of Request	Amount	Approved/Denied	Foundation Left	Previous Balance	Total used	Notes
2											
3											
4											
5											
6											
7											
8											
9											
10											
11											
12											
13											
14											
15											
16											
17											
18											
19											
20											

# EL RIO HEALTH

<b>POLICY DESCRIPTION:</b> Cancer Treatment Funds Request	<b>REFERENCE NUMBER:</b> ADM-026
<b>PAGE:</b> 5 of 5	<b>EFFECTIVE DATE:</b>

## Attachment C



Supporting  
El Rio Health  
839 West Congress street, Tucson, AZ 85745  
P: (520) 205-4947 F: (520) 205-4995  
[www.elriofoundation.org](http://www.elriofoundation.org)

### El Rio Health Foundation Partnership Agreement (Cervical Cancer Program)

Dear: \_\_\_\_\_ Date: \_\_\_\_\_  
MRN: \_\_\_\_\_

Good News! Your treatment plan will be paid as a result of the generosity of members of our Tucson community. Each year El Rio Health Foundation donors help thousands of people in need in our community. This opportunity allows you to receive **up to a maximum of \$15,000** towards your cervical cancer treatment.

**Please note – this is a one-time gift and only a limited number of people are helped annually.**

#### Acknowledgement:

I, \_\_\_\_\_ have read the above and I understand the services I will receive; I understand I am receiving a one-time gift **up to a maximum of \$15,000** towards my cervical cancer treatment, and I am responsible for any additional medical expenses I may accrue.

Patient Signature \_\_\_\_\_ Date: \_\_\_\_\_

-----  
*We need your help to continue this program for other patients. Do you appreciate what this program will do for you? If the answer is "yes", then would you be willing to be interviewed for this program or write a letter of thanks that will be shared with potential donors and EL Rio Foundation Board members? Our supporters and staff would love to hear how you have been helped through the partnership program! Your story may motivate a donor to contribute to this program and help other people just like you in the community.*

**Yes! I would like to share my story and give thanks!**

Name \_\_\_\_\_

Contact Phone # or E-mail \_\_\_\_\_

# EL RIO HEALTH

**SCOPE:**

This policy applies to **CLINICAL** and **NON-CLINICAL** departments in the following El Rio Health functional areas and/or locations (check all that apply):

- |   |   |   |  |
|---|---|---|--|
| <input checked="" type="checkbox"/> Family Medicine   | <input checked="" type="checkbox"/> Same Day Appt. Clinic | <input type="checkbox"/> Radiology              | <input type="checkbox"/> MOR/DOS         |
| <input checked="" type="checkbox"/> Internal Medicine | <input type="checkbox"/>                                  | <input type="checkbox"/> Pharmacy               | <input type="checkbox"/> Administration  |
| <input checked="" type="checkbox"/> Pediatrics        | <input checked="" type="checkbox"/> HOB/HOU               | <input type="checkbox"/> Laboratory             | <input type="checkbox"/> Human Resources |
| <input type="checkbox"/> Dental                       | <input checked="" type="checkbox"/> SIA                   | <input type="checkbox"/> HIM                    | <input type="checkbox"/> Accounting      |
| <input checked="" type="checkbox"/> Behavioral Health |   | <input type="checkbox"/> Information Technology | <input type="checkbox"/> Business Office |
| <input checked="" type="checkbox"/> Midwives          | <input type="checkbox"/>                                  | <input type="checkbox"/> Patient Communications | <input type="checkbox"/> Coding          |
| <input checked="" type="checkbox"/> OB/GYN            | <input checked="" type="checkbox"/> Care Coordination     | <input type="checkbox"/> Advocacy & Eligibility | <input type="checkbox"/> Security        |
| <input type="checkbox"/> Clinical Pharmacy            | <input type="checkbox"/> Wellness                         | <input type="checkbox"/> Facilities/Materials   | <input type="checkbox"/> Transportation  |

<b>POLICY DESCRIPTION:</b> Depression Screening	<b>PAGE:</b> 1 of 6
	<b>REFERENCE NUMBER:</b> COP-035
<b>APPROVAL DATE:</b>	<b>DATES REVIEWED WITHOUT CHANGE:</b>
<b>EFFECTIVE DATE:</b>	<b>REPLACES POLICY DATED:</b> 12/2018:12/2020:01/2022
<b>NEXT REVIEW DATE:</b>	<b>DATE RETIRED:</b> N/A
<b>RESPONSIBILITY:</b> Medical Directors Regional Directors Chief of Behavioral Health and Integration Director of Integrated Behavioral Health Programs Behavioral Health Clinical Director Behavioral Health Program Manager Pediatric Behavioral Health Program Manager	<b>APPROVALS:</b> PPC: CAC: Board:

**POLICY:** It is the policy of El Rio Health to provide clinic staff with a procedure to follow when performing depression screening and documentation of a follow-up plan when applicable.

**PROCEDURE:**

Depression screening will be performed at least once a year for every medical patient **12 years** old and older.

- I. The following steps will be taken if the Depression Screening is filled out on the kiosk / tablet:**
1. Depression screening will be provided as part of the intake procedures in the screening questions self-administered by use of the kiosk / tablet. Patients will first complete the PHQ-2 and if they answer **YES** to either question will automatically be asked to respond to the PHQ-9.
  2. The results of the PHQ-2 and / or PHQ-9 will automatically be generated into the screening summary link.
  3. In the event of kiosk / tablet downtime, Depression Screening would revert to downtime paper process. See Section II for details.

# EL RIO HEALTH

<b>POLICY DESCRIPTION:</b> Depression Screening	<b>REFERENCE NUMBER:</b> COP-035
<b>PAGE:</b> 2 of 6	<b>EFFECTIVE DATE:</b>

**II. The following steps will be taken if the Depression Screening is filled out using the paper process.**

1. Patients who do not use the kiosk / tablet will be provided with a paper copy of the PHQ-2 *to complete with their identifying information attached to the Screening Summary Questionnaire.*
2. Nursing will enter the results into Electronic Health Record (EHR) for patients using the paper copy via screening summary link.
3. If the patient answers “**YES**” to any question on the PHQ-2, give the patient a paper copy of the PHQ-9 **questionnaire to complement with their identifying information attached.**
4. Nursing enters the data from the paper PHQ-9 into EHR via the screening summary link before the provider sees the patient *and leaves the PHQ-9 in the exam room to be reviewed by the provider.*

**III. EHR Downtime:**

- If the EHR System is down, all screening summary responses must be placed in EHR when it is back up. See COP-002 “Emergency procedure for computer / phone systems failure / interruptions” for reference.

**IV. The following steps will be taken after the patient has filled out their portion of the Depression Screening:**

1. If the PHQ score is 5 or greater – OR - if question 9 is positive for thoughts of self-harm, always notify the Medical Provider and if available, the Behavioral Health Consultant.
2. The Medical Provider will document a follow-up plan for all patients who score 5 or greater on the PHQ-9 and / or if question 9 is positive for thoughts of self-harm, **which will include any of the options listed in Attachment A.**
3. All providers will follow standard operating procedures for documenting Depression Screening follow up plan (see Attachment A).
4. Screening tools PHQ-2, PHQ-9 in English / Spanish can be found on SharePoint under company resources, Integrated Behavioral Health Toolkit, “2017 Mobile Toolkit Update”, Depression folder, scroll down to the PHQ documents section.
5. (See Attachment A, B and C for example of forms).

# EL RIO HEALTH

<b>POLICY DESCRIPTION:</b> Depression Screening	<b>REFERENCE NUMBER:</b> COP-035
<b>PAGE:</b> 3 of 6	<b>EFFECTIVE DATE:</b>

## Attachment A

### **Adult Medicine, Family Practice Providers, Mid-Wives, OB/GYN, Pediatric Providers, Clinical Pharmacy Standard Operating Procedure – Depression Screening Follow Up**

1. Providers will document a depression screening follow-up plan for all patients who score 5 or greater **which will include any of the options listed below:**
  - a. Referral Order for Primary Care Behavioral Health Professional (aka; Behavioral Health Consultant or BHC), El Rio Behavioral Health Specialty Care or similar.
  - b. Suicide Risk Assessment (located in the Screening Tools) .
  - c. Health Promotion Plan – specifying lifestyle, behavioral and self-management plan.
  - d. Medication management plan.
  - e. BHC health behavior intervention via medical provider warm hand off.
  - f. **Address in assessment / plan.**

# EL RIO HEALTH

<b>POLICY DESCRIPTION:</b> Depression Screening	<b>REFERENCE NUMBER:</b> COP-035
<b>PAGE:</b> 4 of 6	<b>EFFECTIVE DATE:</b>

## Attachment B

### DEPRESSION SCREENING PHQ 2

Name \_\_\_\_\_ Date \_\_\_\_\_

Date of birth \_\_\_\_\_

Over the last 2 weeks, how often have you been bothered by any of the following problems?

	Not at all <b>0</b>	Several days <b>1</b>	More than half the days <b>2</b>	Nearly every day <b>3</b>
Little interest or pleasure in doing things				
Feeling down, depressed, or hopeless				

En las últimas 2 semanas, ¿cuánto le han afectado (molestado) los siguientes problemas?

	Nada <b>0</b>	Varios días <b>1</b>	Más de la mitad de los días <b>2</b>	Casi todos los días <b>3</b>
No le interesa hacer nada o no se divierte cuando hace cosas que le divertían antes				
Se siente deprimido/a o sin esperanzas				

Today's Date: \_\_\_\_\_

Patient Name: \_\_\_\_\_ Date of Birth: \_\_\_\_\_

# EL RIO HEALTH

<b>POLICY DESCRIPTION:</b> Depression Screening	<b>REFERENCE NUMBER:</b> COP-035
<b>PAGE:</b> 5 of 6	<b>EFFECTIVE DATE:</b>

## Attachment C

Today's Date: \_\_\_\_\_

Patient Name: \_\_\_\_\_ Date of Birth: \_\_\_\_\_

### Patient Health Questionnaire – 9 - English

Over the last 2 weeks, how often have you been bothered by any of the following problems?

Not at all	Several days	More than half the days	Nearly every day
<b>0</b>	<b>1</b>	<b>2</b>	<b>3</b>

	0	1	2	3
Little interest or pleasure in doing things				
Feeling down, depressed, or hopeless				
Trouble falling / staying asleep, sleeping too much				
Feeling tired or having little energy				
Poor appetite or overeating				
Feeling bad about yourself; or that you are a failure or have let yourself or your family down				
Trouble concentrating on things, such as reading the newspaper or watching television				
Moving or speaking so slowly that other people could have noticed. Or the opposite; being so fidgety or restless that you have been moving around a lot more than usual				
Thoughts that you would be better off dead or of hurting yourself in some way				

How difficult have these problems made it for you to do your work, take care of things at home, or get along with other people? (circle one)

Not difficult at all (1) Somewhat Difficult (2) Very Difficult (3) Extremely Difficult (4)

## EL RIO HEALTH

<b>POLICY DESCRIPTION:</b> Depression Screening	<b>REFERENCE NUMBER:</b> COP-035
<b>PAGE:</b> 6 of 6	<b>EFFECTIVE DATE:</b>

### Patient Health Questionnaire – 9 - Spanish

En las últimas 2 semanas, ¿cuánto le han afectado (molestado) los siguientes problemas?

	Nada <b>0</b>	Varios días <b>1</b>	Más de la mitad de los días <b>2</b>	Casi todos los días <b>3</b>
No le interesa hacer nada o no se divierte cuando hace cosas que le divertían antes				
Se siente deprimido/a o sin esperanzas				
Le es difícil dormir/quedarse dormido/a, duerme mucho				
Se siente cansado/a, no tiene energía				
No le da hambre; o come de más				
No está satisfecho/a con usted mismo/a; piensa que les ha fallado a su familia y a usted mismo/a				
No puede concentrarse en cosas, como leer un periódico o mirar la televisión.				
Se mueve o habla muy despacio, tanto que otras personas se dan cuenta. O lo opuesto; está nervioso y se ha estado moviendo más de lo normal				
Ideas que estaría mejor muerto/a o piensa en maneras de hacerse daño				

¿Qué difícil han hecho estos problemas para hacer su trabajo, para ocuparse (atender) de asuntos que pasan en su hogar, o para llevarse bien con otras personas?

Nada difícil (1)    Algo difícil (2)    Muy difícil (3)    Dificilísimo (4)

**REFERENCES:**

**COP-002 Emergency procedure for computer / phone systems failure / interruption**

# EL RIO HEALTH

**SCOPE:**

This policy applies to **CLINICAL** and **NON-CLINICAL** departments in the following El Rio Health functional areas and/or locations (check all that apply):

- |  |  |   |  |
|--|--|---|--|
| <input type="checkbox"/> Family Medicine   | <input type="checkbox"/> Same Day Appt. Clinic | <input type="checkbox"/> Radiology              | <input type="checkbox"/> MOR / DOS       |
| <input type="checkbox"/> Internal Medicine | <input type="checkbox"/> HOB/HOU               | <input type="checkbox"/> Pharmacy               | <input type="checkbox"/> Administration  |
| <input type="checkbox"/> Pediatrics        | <input type="checkbox"/> SIA                   | <input type="checkbox"/> Laboratory             | <input type="checkbox"/> Human Resources |
| <input type="checkbox"/> Dental            | <input type="checkbox"/> Care Coordination     | <input type="checkbox"/> HIM                    | <input type="checkbox"/> Accounting      |
| <input type="checkbox"/> Behavioral Health | <input type="checkbox"/> Wellness              | <input type="checkbox"/> Information Technology | <input type="checkbox"/> Business Office |
| <input type="checkbox"/> Midwives          | <input type="checkbox"/> Clinical Pharmacy     | <input type="checkbox"/> Patient Communications | <input type="checkbox"/> Coding          |
| <input type="checkbox"/> OB/GYN            | <input checked="" type="checkbox"/> Facilities | <input type="checkbox"/> Advocacy & Eligibility | <input type="checkbox"/> Security        |
|  | <input type="checkbox"/> Purchasing            |   | <input type="checkbox"/> Transportation  |

<p><b>PROCEDURE DESCRIPTION:</b> Adjustable Workstation (Stand Desks and Office Chairs)</p>	<p><b>PAGE:</b> 1 of 2</p>
	<p><b>REFERENCE NUMBER:</b> FAC-400-SOP-421</p>
<p><b>APPROVAL DATE:</b></p>	<p><b>DATES REVIEWED WITHOUT CHANGE:</b></p>
<p><b>EFFECTIVE DATE:</b></p>	<p><b>REPLACES PROCEDURE DATED:</b> 06/2022</p>
<p><b>NEXT REVIEW DATE:</b></p>	<p><b>DATE RETIRED:</b> N/A</p>
<p><b>RESPONSIBILITY:</b> Facilities Director Facilities Manager</p>	<p><b>APPROVALS:</b> PPC: CAC:</p>

**PURPOSE:** It is the policy of El Rio Health to establish a process for El Rio Health employees to understand what will qualify an employee to be assigned an adjustable workstation.

**PROCEDURE:**

There are two circumstances that would allow an El Rio employee to receive an Adjustable Workstation (stand desk) or any other type of office chair other than the standard Bodybuilt Brand. (#2708 or #2758)

- If an El Rio Health employee has a medical need and a doctor’s note.
- If an El Rio Health Employee is stationed for long periods at their desk and do not leave their desk and move around frequently.

Before the stand desk will be ordered, there will be a workstation evaluation by the Facilities Manager to determine if the workstation will accommodate the stand desk. A doctor’s note should be presented to your manager. Your manager will requisition the stand desk or chair from Purchasing.

These two circumstances will also apply to employees working from home. This will also be evaluated at the Home Office Physical Environment Checklist. Shared workstations will not be evaluated for a stand desk due

# EL RIO HEALTH

<b>PROCEDURE DESCRIPTION:</b> Adjustable Workstation (Stand Desks and Office Chairs)	<b>REFERENCE NUMBER:</b> FAC-400-SOP-421
<b>PAGE:</b> 2 of 2	<b>EFFECTIVE DATE:</b>

to the short work hours of the users.

When the stand desk is delivered to Manning II, the manager will need to generate a Netfacilities Workorder request for installation. After the stand desk is installed, the manager will need to generate an IT JIRA service desk request to install the monitors on the Stand Desk.

## REFERENCES:

## PROCEDURE:

The circumstances that would allow an El Rio Health employee in an existing area to receive an Adjustable Workstation (stand desk) or an office chair other than the standard Body Built Brand are as follow:

- A doctor's evaluation and recommendation will be submitted to the clinic or department Manager. The requestor must be sitting 90% of the time in their work area. In addition, the space will be evaluated to determine if the accommodation can be made.
- Office furniture will not be modified to accommodate Adjustable workstations when furniture is in good condition (No hutch removal, cabinet removal, or desk modification / relocation). Desk with a hutch or overhead cabinets will not accommodate a stand desk.
- An employee must work on-site at least 4 days per week to be considered for an Adjustable desk or height adjustable stand. Shared workstations will not be accommodated for a stand desk due to the short work hours of the users.
- After the employee's circumstances have been evaluated and does not meet the above criteria, the clinic or department manager then should look for other alternatives, such as possibly relocating the employee to an area that would accommodate an adjustable workstation.
- The Body Built chairs are ergonomic and can be adjusted to accommodate the employee's comfort. If the employee is experiencing any issue with the mechanics of the chair or discomfort due to a medical reason, contact the Purchasing Department to have the chair adjusted by the vendor.

All the above are considered reasonable accommodations for El Rio Health employees and any exception requires higher level involvement. If the clinic / department manager or the Regional Director cannot find a solution, when all reasonable accommodations have been exhausted, under extenuating circumstances the Department Director should contact the Director of Facilities and Environmental Services for a possible solution.

A requisition through Purchasing, and an IT JIRA service desk ticket must be submitted to generate the purchase and to initiate IT to dispatch a service technician to install the monitors on the desk.

# EL RIO HEALTH

**SCOPE:**

This Policy applies to **CLINICAL** and **NON-CLINICAL** departments in the following El Rio Health functional areas and/or locations (check all that apply):

- |  |  |   |  |
|--|--|---|--|
| <input type="checkbox"/> Family Medicine   | <input type="checkbox"/> Same Day Appt. Clinic | <input type="checkbox"/> Radiology              | <input type="checkbox"/> MOR/DOS                   |
| <input type="checkbox"/> Internal Medicine | <input type="checkbox"/> HOB/HOU               | <input type="checkbox"/> Pharmacy               | <input checked="" type="checkbox"/> Administration |
| <input type="checkbox"/> Pediatrics        | <input type="checkbox"/> SIA                   | <input type="checkbox"/> Laboratory             | <input type="checkbox"/> Human Resources           |
| <input type="checkbox"/> Dental            | <input type="checkbox"/> Care Coordination     | <input type="checkbox"/> HIM                    | <input checked="" type="checkbox"/> Accounting     |
| <input type="checkbox"/> Behavioral Health | <input type="checkbox"/> Wellness              | <input type="checkbox"/> Information Technology | <input type="checkbox"/> Business Office           |
| <input type="checkbox"/> Midwives          | <input type="checkbox"/> Clinical Pharmacy     | <input type="checkbox"/> Patient Communications | <input type="checkbox"/> Coding                    |
| <input type="checkbox"/> OB/GYN            | <input type="checkbox"/> Facilities            | <input type="checkbox"/> Advocacy & Eligibility | <input type="checkbox"/> Security                  |
| <input type="checkbox"/> Referrals         | <input type="checkbox"/> Purchasing            | <input type="checkbox"/> Physical Therapy       | <input type="checkbox"/> Transportation            |

**POLICY DESCRIPTION:**

Grant Expense Coding

**PAGE:**

1 of 2

**REFERENCE NUMBER:**

FIN-ACCT-001-SOP-001

**APPROVAL DATE:**

**DATES REVIEWED WITHOUT CHANGE:**

**EFFECTIVE DATE:**

**REPLACES POLICY DATED:**

**NEW**

**NEXT REVIEW DATE:**

**DATE RETIRED:**

**RESPONSIBILITY:**

Chief Financial Officer

**APPROVALS:**

PPC:

CAC:

Board:

**POLICY:** El Rio Health demonstrates that grant revenue is spent for its intended purpose by coding expenses to the applicable general ledger grant tracking dimension in the general ledger. Grants are spent in accordance with allowable costs as specified in 45 CFR Part 75 Subpart E. The general ledger system produces income statements by grant to reflect grant revenue and expenses and net income.

**PROCEDURE:**

1. Grants are set up by unique grant code in the general ledger system to track revenue and expenses by grant.
2. Grant expenses processed by accounts payable can be coded directly to the grant using the unique grant code.
3. Expenses recorded to the general ledger can be allocated to specific grants using journal entries to code expenses to grants using the unique grant code.
4. Health Resources and Services Administration (HRSA) 330 grant is specifically used to record payroll expenses.
5. Monthly, payroll journal entry lines are coded with the 330 HRSA grant code to collect payroll expenses up to the amount of the monthly 330 grant revenue.

# EL RIO HEALTH

<b>POLICY DESCRIPTION:</b> Grant Expense Coding	<b>REFERENCE NUMBER:</b> FIN-ACCT-001-SOP-001
<b>PAGE:</b> 2 of 2	<b>EFFECTIVE DATE:</b>

- 6. Monthly, each grant income statement is reviewed to ensure that grant expenses equal grant revenue and that grant expenses are for allowable expenses in accordance with allowable costs as specified in 45 CFR Part 75 Subpart E.

**REFERENCES:** N/A

# EL RIO HEALTH

**SCOPE:**

This Policy applies to **CLINICAL** and **NON-CLINICAL** departments in the following El Rio Health functional areas and/or locations (check all that apply):

- |  |  |   |  |
|--|--|---|--|
| <input type="checkbox"/> Family Medicine   | <input type="checkbox"/> Same Day Appt. Clinic | <input type="checkbox"/> Radiology              | <input type="checkbox"/> MOR/DOS               |
| <input type="checkbox"/> Internal Medicine | <input type="checkbox"/> HOB/HOU               | <input type="checkbox"/> Pharmacy               | <input type="checkbox"/> Administration        |
| <input type="checkbox"/> Pediatrics        | <input type="checkbox"/> SIA                   | <input type="checkbox"/> Laboratory             | <input type="checkbox"/> Human Resources       |
| <input type="checkbox"/> Dental            | <input type="checkbox"/> Care Coordination     | <input type="checkbox"/> HIM                    | <input checked="" type="checkbox"/> Accounting |
| <input type="checkbox"/> Behavioral Health | <input type="checkbox"/> Wellness              | <input type="checkbox"/> Information Technology | <input type="checkbox"/> Business Office       |
| <input type="checkbox"/> Midwives          | <input type="checkbox"/> Clinical Pharmacy     | <input type="checkbox"/> Patient Communications | <input type="checkbox"/> Coding                |
| <input type="checkbox"/> OB/GYN            | <input type="checkbox"/> Facilities            | <input type="checkbox"/> Advocacy & Eligibility | <input type="checkbox"/> Security              |
| <input type="checkbox"/> Referrals         | <input type="checkbox"/> Purchasing            | <input type="checkbox"/> Physical Therapy       | <input type="checkbox"/> Transportation        |

<p><b>POLICY DESCRIPTION:</b> Balance Sheet Reconciliations</p>	<p><b>PAGE:</b> 1 of 2</p>
	<p><b>REFERENCE NUMBER:</b> FIN-ACCT-001-SOP-002</p>
<p><b>APPROVAL DATE:</b></p>	<p><b>DATES REVIEWED WITHOUT CHANGE:</b></p>
<p><b>EFFECTIVE DATE:</b></p>	<p><b>REPLACES POLICY DATED:</b> <b>NEW</b></p>
<p><b>NEXT REVIEW DATE:</b></p>	<p><b>DATE RETIRED:</b></p>
<p><b>RESPONSIBILITY:</b> Chief Financial Officer</p>	<p><b>APPROVALS:</b> PPC: CAC: Board:</p>

**POLICY:** El Rio Health reconciles each balance sheet account monthly to ensure that the balance is valid and accurate and that it is properly documented in an audit schedule that is easy to understand and supported by appropriate documentation at the balance sheet date.

**PROCEDURE:**

1. For each balance sheet account, the elements comprising that balance are collected on a working paper spreadsheet and itemized or portrayed in such a way that any reader clearly understands the components of the balance sheet account at the balance sheet date.
2. Each component of each balance sheet account balance is supported by appropriate documentation that demonstrates the accuracy and validity of the component of the balance sheet account at the balance sheet date.
3. Balance sheet accounts that are comprised of or include management estimates are supported by working paper spreadsheets that reflect reasonable assumptions and analysis pertinent to the balance sheet account and demonstrate the accuracy and validity of the balance sheet account at the balance sheet date.
4. Each balance sheet audit schedule is comprised of the working paper spreadsheets and the appropriate

# EL RIO HEALTH

<b>POLICY DESCRIPTION:</b> Balance Sheet Reconciliations	<b>REFERENCE NUMBER:</b> FIN-ACCT-001-SOP-002
<b>PAGE:</b> 2 of 2	<b>EFFECTIVE DATE:</b>

documentation that demonstrates the accuracy and validity of the balance sheet account at the balance sheet date.

**REFERENCES:** N/A

# EL RIO HEALTH

**SCOPE:**

This Procedure applies to **CLINICAL** and **NON-CLINICAL** departments in the following El Rio Health functional areas and/or locations (check all that apply):

- |  |  |   |  |
|--|--|---|--|
| <input type="checkbox"/> Family Medicine   | <input type="checkbox"/> Same Day Appt. Clinic | <input type="checkbox"/> Radiology              | <input type="checkbox"/> MOR/DOS         |
| <input type="checkbox"/> Internal Medicine | <input type="checkbox"/> HOB/HOU               | <input type="checkbox"/> Pharmacy               | <input type="checkbox"/> Administration  |
| <input type="checkbox"/> Pediatrics        | <input type="checkbox"/> SIA                   | <input type="checkbox"/> Laboratory             | <input type="checkbox"/> Human Resources |
| <input type="checkbox"/> Dental            | <input type="checkbox"/> Care Coordination     | <input checked="" type="checkbox"/> HIM         | <input type="checkbox"/> Accounting      |
| <input type="checkbox"/> Behavioral Health | <input type="checkbox"/> Wellness              | <input type="checkbox"/> Information Technology | <input type="checkbox"/> Business Office |
| <input type="checkbox"/> Midwives          | <input type="checkbox"/> Clinical Pharmacy     | <input type="checkbox"/> Patient Communications | <input type="checkbox"/> Coding          |
| <input type="checkbox"/> OB/GYN            | <input type="checkbox"/> Facilities            | <input type="checkbox"/> Advocacy & Eligibility | <input type="checkbox"/> Security        |
| <input type="checkbox"/> Referrals         | <input type="checkbox"/> Purchasing            | <input type="checkbox"/> Physical Therapy       | <input type="checkbox"/> Transportation  |

<p><b>PROCEDURE DESCRIPTION:</b> Exporting Patient Data from Galen into EPIC's Release Template (Export Chart vs. Build an Export)</p>	<p><b>PAGE:</b> 1 of 7</p>
	<p><b>REFERENCE NUMBER:</b> HIM-002-SOP-ROI-018</p>
<p><b>APPROVAL DATE:</b></p>	<p><b>DATES REVIEWED WITHOUT CHANGE:</b></p>
<p><b>EFFECTIVE DATE:</b></p>	<p><b>REPLACES PROCEDURE DATED:</b> 01/2023</p>
<p><b>NEXT REVIEW DATE:</b></p>	<p><b>DATE RETIRED:</b> N/A</p>
<p><b>RESPONSIBILITY:</b> HIPAA Privacy Office HIM Management</p>	<p><b>APPROVALS:</b> PPC: CAC:</p>

**PURPOSE:** To assist Health Information Management (HIM) staff in exporting **multiple documents** to the **release of information template and viewing** patient data from Galen (<https://elrio.vitalcenteronline.com/login/>) through the EPIC application.

- PROCEDURE:**
1. Once a release is created in EPIC for a patient (see standard operating procedure *HIM-002-SOP-ROI-017 Creating and Completing a NEW Release Request in Electronic Health Record (EHR)* and Galen documents need inserted into the existing release:
    - a. Select **Chart Central**
    - b. Double click on patient
    - c. Select **Chart Review** Tab
    - d. Select **Media** tab

# EL RIO HEALTH

**PROCEDURE DESCRIPTION:**

Exporting Patient Data from Galen into EPIC's Release Template (Export Chart vs. Build an Export)

**REFERENCE NUMBER:**

HIM-002-SOP-ROI-018

**PAGE:** 2 of 7

**EFFECTIVE DATE:**

- e. Select **Hx EHR** tab

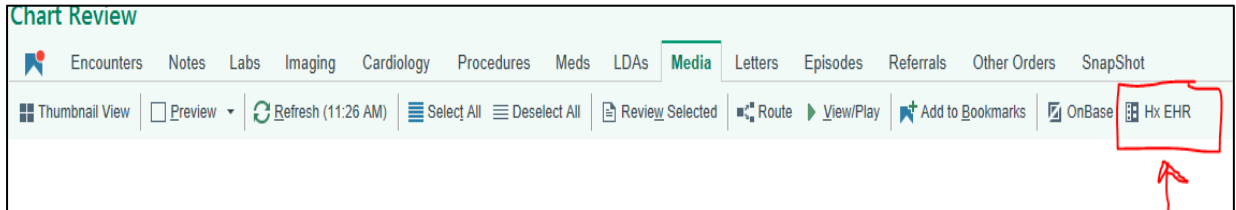

2. Galen will open in a separate browser (automatically logging you in) and patient's chart will display on the right-hand side displaying old EHR as follows\*\*:

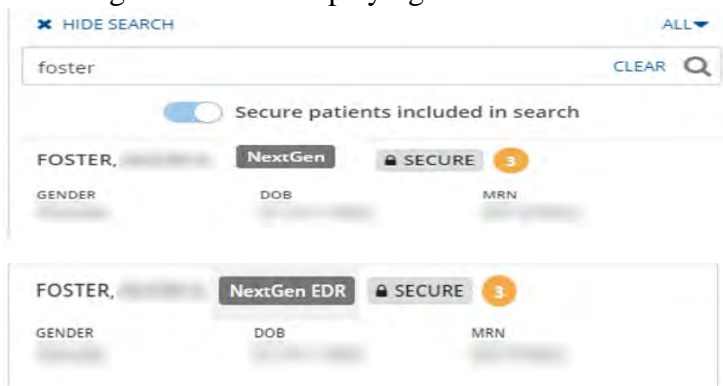

\*\*The Medical Chart will be associated with the **NextGen** button

\*\*The Dental Chart will be associated with the **NextGen EDR** button

3. Select patient's medical or dental chart by clicking on it so it is highlighted. The chart will now display on the left-hand side of Galen. If requestor is asking for one specific report switch to standard operating procedure [HIM-002-SOP-ROI-019 Exporting and Viewing a Single Report in Galen](#) otherwise continue to step 4.

4. If requestor is asking for multiple reports, click **EXPORT** button located at the top of the chart (a side bar will display on the right). Select **Export chart** (step 5) which allows you to select multiple individual categories or **Build an Export** (step 6) which allows you to select multiple individual documents.

# EL RIO HEALTH

<b>PROCEDURE DESCRIPTION:</b> Exporting Patient Data from Galen into EPIC's Release Template (Export Chart vs. Build an Export)	<b>REFERENCE NUMBER:</b> HIM-002-SOP-ROI-018
<b>PAGE:</b> 3 of 7	<b>EFFECTIVE DATE:</b>

## 5. If **Export Chart** was selected in step 4:

- a. Select your export type: **Default/Custom/Create template** then click **continue button**



The screenshot shows the 'Export Chart' dialog box with the title 'Export Chart' and a close button (X) in the top right corner. Below the title is the instruction 'Select an export type to get started'. There are three radio button options: 'Default' (selected), 'Template', and 'Custom / Create template'. Under 'Default', there is a text box containing 'Your export will include commonly required patient data...'. Under 'Template', there is a text box containing 'Select template'. Under 'Custom / Create template', there is a text box containing 'Select only the patient information you need and optionally save your settings as a template...'. At the bottom left is a 'CANCEL' button and at the bottom right is a 'CONTINUE' button.

- b. Filter chart and enter date type: **encounter** or **clinically relevant**. Then enter date range and click **continue** (located at the bottom of the box)

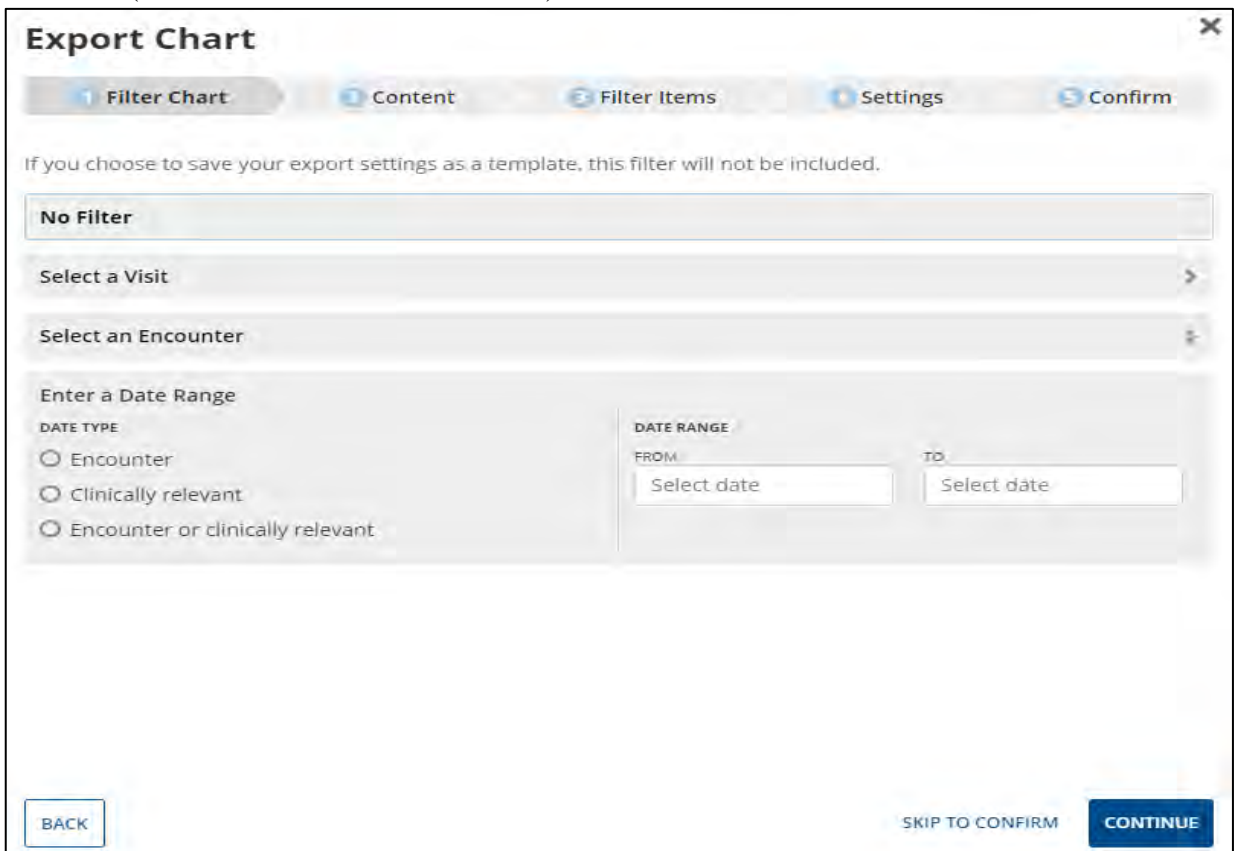

The screenshot shows the 'Export Chart' dialog box with the title 'Export Chart' and a close button (X) in the top right corner. Below the title is a progress bar with five steps: 'Filter Chart' (active), 'Content', 'Filter Items', 'Settings', and 'Confirm'. Below the progress bar is the instruction 'If you choose to save your export settings as a template, this filter will not be included.' There are three dropdown menus: 'No Filter', 'Select a Visit', and 'Select an Encounter'. Below these is a section titled 'Enter a Date Range' with a 'DATE TYPE' section containing three radio button options: 'Encounter', 'Clinically relevant', and 'Encounter or clinically relevant'. To the right is a 'DATE RANGE' section with 'FROM' and 'TO' labels and two date selection boxes, each containing the text 'Select date'. At the bottom left is a 'BACK' button and at the bottom right are 'SKIP TO CONFIRM' and 'CONTINUE' buttons.

# EL RIO HEALTH

<b>PROCEDURE DESCRIPTION:</b> Exporting Patient Data from Galen into EPIC's Release Template (Export Chart vs. Build an Export)	<b>REFERENCE NUMBER:</b> HIM-002-SOP-ROI-018
<b>PAGE:</b> 4 of 7	<b>EFFECTIVE DATE:</b>

- c. Select/unselect content to be included/excluded with the records: documents and results will print pertinent information (make sure to check attachments boxes). When done selecting click **continue** (located at the bottom of the box). See example below:

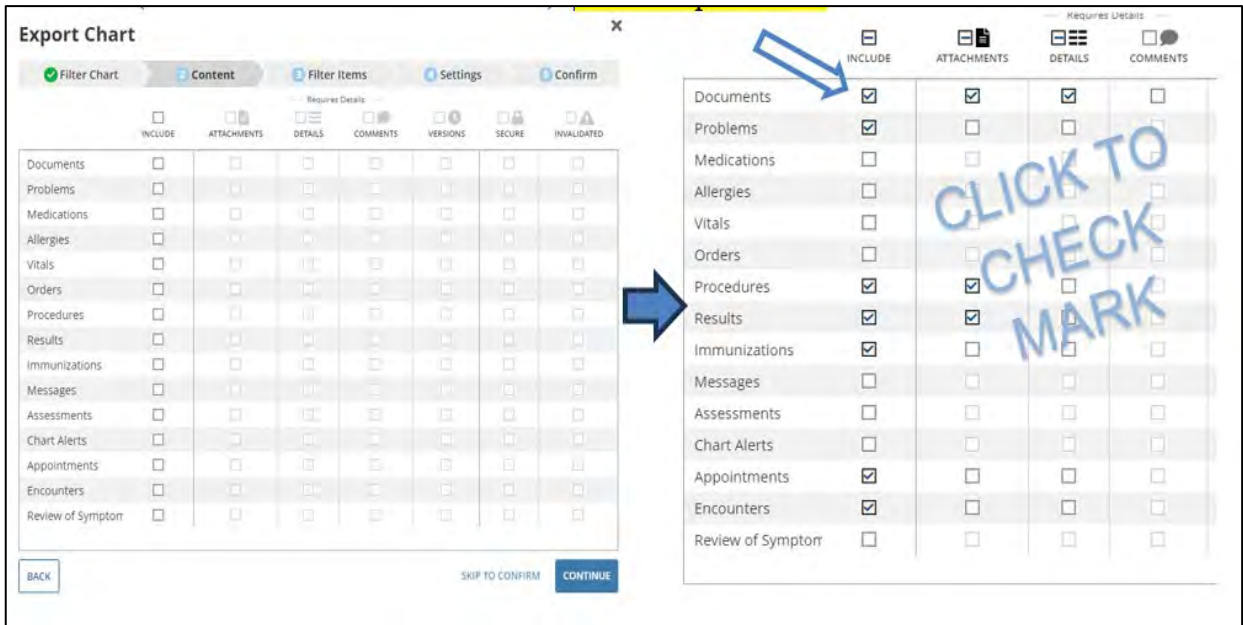

- d. Filter documents: search for document types needed, select document, and move the document from the left-sided box to the right-sided box using the arrows provided. Please Note when using this template, you will need to know what category names are associated with what reports because patient data cannot be viewed in this window. When done selecting documents click **continue** (located at the bottom of the box)

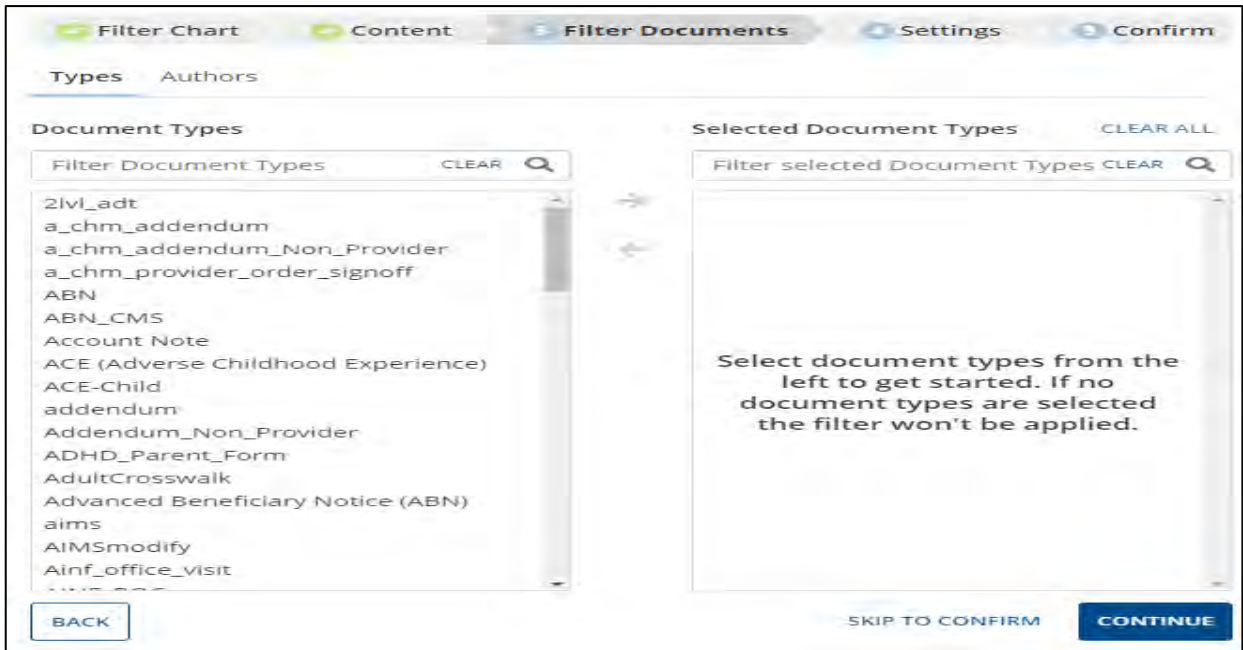

# EL RIO HEALTH

<b>PROCEDURE DESCRIPTION:</b> Exporting Patient Data from Galen into EPIC's Release Template (Export Chart vs. Build an Export)	<b>REFERENCE NUMBER:</b> HIM-002-SOP-ROI-018
<b>PAGE:</b> 5 of 7	<b>EFFECTIVE DATE:</b>

- e. In the settings area deselect "header pages" checkbox ~~select "exclude header pages"~~ and click **append** under attachments. Then click **continue** (located at the bottom of the box)

**HEADER PAGES**  
These include the cover, table of contents, settings, and about pages  
 Include header pages

**ATTACHMENTS**  
 Append - Attachments will be included at the end of the chart PDF.  
 Include as separate files - Export will be a single download containing multiple files.

- f. Confirm your selections and click **Export** (skip to step 7)

## 6. If **Build an Export** was selected in step 4:

- a. Use documents bar across the top to locate the individual documents needed for the release

**Documents** [Filter documents] [CLEAR] [Q]

Account Note Chart Note Document ICS Images Images Ins Cards Patient Photo Quick Note Telephone Summary Other

SELECT ALL  DESELECT ALL

- b. **Select All** or choose individually by clicking (check marking) the small boxes located next to the document type. You will now see those documents listed on the right-hand side. Click **Export** (located on the bottom of the screen)

SELECT ALL  DESELECT ALL

Type ▾

<input checked="" type="checkbox"/>	Correspondence
<input checked="" type="checkbox"/>	Correspondence
<input checked="" type="checkbox"/>	DENTAL
<input type="checkbox"/>	DENTAL
<input type="checkbox"/>	HIPAA
<input type="checkbox"/>	Miscellaneous Forms



**Build an Export** [CLEAR ALL]

**DOCUMENTS**

- Correspondence
- Correspondence
- DENTAL

[CANCEL] [EXPORT]

# EL RIO HEALTH

<b>PROCEDURE DESCRIPTION:</b> Exporting Patient Data from Galen into EPIC's Release Template (Export Chart vs. Build an Export)	<b>REFERENCE NUMBER:</b> HIM-002-SOP-ROI-018
<b>PAGE:</b> 6 of 7	<b>EFFECTIVE DATE:</b>

- c. Confirm selected content to be included with the records: documents and results will print what is selected (make sure to check attachment boxes)

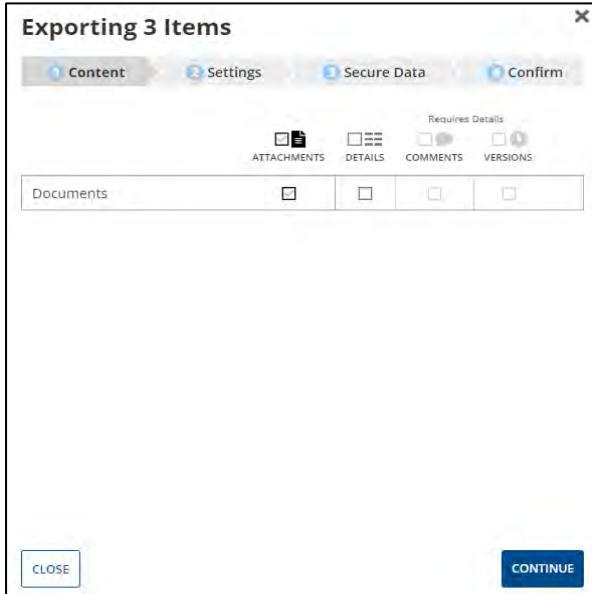

- d. In the settings area **deselect "header pages" checkbox** ~~select "exclude header pages"~~ and click **append** under attachments. Then click **continue** (located at the bottom of the box)

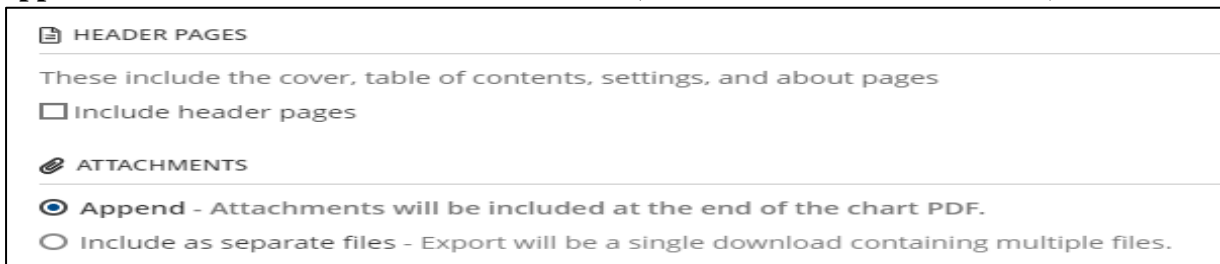

- e. Confirm your selections and click **Export** (go on to step 7).

7. The file will start to generate. Click download when completed and save the file to the HIM designated area (computer/drive) in PDF format. Then Go back to your patient's Release of Information template located in EPIC

8. In the output section of the release template:

- Click **+ File** to insert
- A window will populate so you may locate your saved Galen file (PDF) from step 7.**

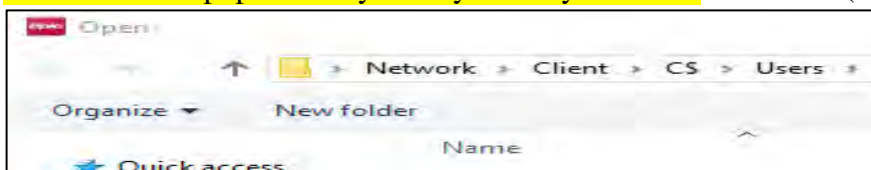

# EL RIO HEALTH

<b>PROCEDURE DESCRIPTION:</b> Exporting Patient Data from Galen into EPIC's Release Template (Export Chart vs. Build an Export)	<b>REFERENCE NUMBER:</b> HIM-002-SOP-ROI-018
<b>PAGE:</b> 7 of 7	<b>EFFECTIVE DATE:</b>

c. Once saved file is located click **open** (located at the bottom right of window)

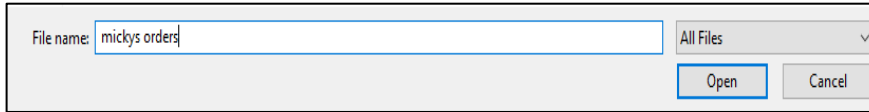

d. Window will populate allowing you to change title name/description

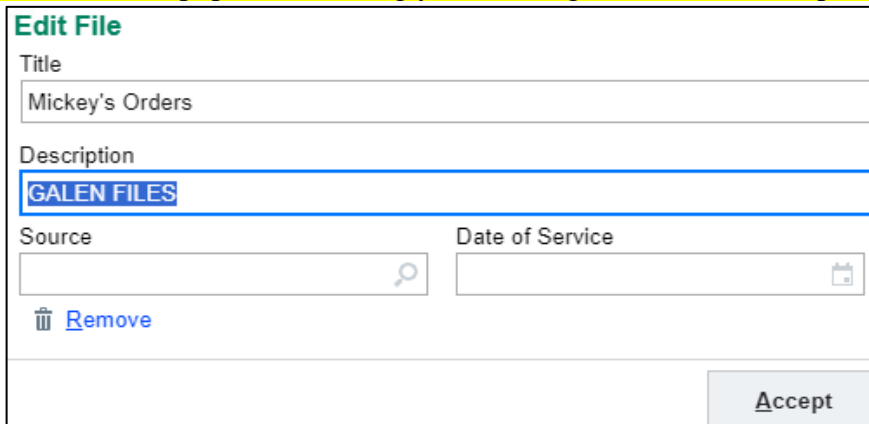

e. Click **accept** to insert

f. When ready to print or fax out click deliver in release template. Reference standard operating procedure *HIM-002-SOP-ROI-017 Creating and Completing a NEW Release Request in Electronic Health Record (EHR)*.

## REFERENCES:

HIM-002-SOP-ROI-017 Creating and Completing a NEW Release Request in Electronic Health Record  
HIM-002-SOP-ROI-019 Exporting and Viewing a Single Report in Galen

# EL RIO HEALTH

**SCOPE:**

This Procedure applies to **CLINICAL** and **NON-CLINICAL** departments in the following El Rio Health functional areas and/or locations (check all that apply):

- |  |  |   |  |
|--|--|---|--|
| <input type="checkbox"/> Family Medicine   | <input type="checkbox"/> Same Day Appt. Clinic | <input type="checkbox"/> Radiology              | <input type="checkbox"/> MOR/DOS         |
| <input type="checkbox"/> Internal Medicine | <input type="checkbox"/> HOB/HOU               | <input type="checkbox"/> Pharmacy               | <input type="checkbox"/> Administration  |
| <input type="checkbox"/> Pediatrics        | <input type="checkbox"/> SIA                   | <input type="checkbox"/> Laboratory             | <input type="checkbox"/> Human Resources |
| <input type="checkbox"/> Dental            | <input type="checkbox"/> Care Coordination     | <input checked="" type="checkbox"/> HIM         | <input type="checkbox"/> Accounting      |
| <input type="checkbox"/> Behavioral Health | <input type="checkbox"/> Wellness              | <input type="checkbox"/> Information Technology | <input type="checkbox"/> Business Office |
| <input type="checkbox"/> Midwives          | <input type="checkbox"/> Clinical Pharmacy     | <input type="checkbox"/> Patient Communications | <input type="checkbox"/> Coding          |
| <input type="checkbox"/> OB/GYN            | <input type="checkbox"/> Facilities            | <input type="checkbox"/> Advocacy & Eligibility | <input type="checkbox"/> Security        |
| <input type="checkbox"/> Referrals         | <input type="checkbox"/> Purchasing            | <input type="checkbox"/> Physical Therapy       | <input type="checkbox"/> Transportation  |

**PROCEDURE DESCRIPTION:**

Exporting and Viewing a **Single Report** in Galen

**PAGE:**

1 of 5

**REFERENCE NUMBER:**

HIM-002-SOP-ROI-019

**APPROVAL DATE:**

**DATES REVIEWED WITHOUT CHANGE:**

**EFFECTIVE DATE:**

**REPLACES PROCEDURE DATED:**

01/2023

**NEXT REVIEW DATE:**

**DATE RETIRED:**

N/A

**RESPONSIBILITY:**

HIPAA Privacy Office  
HIM Management

**APPROVALS:**

PPC:  
CAC:

**PURPOSE:** To assist Health Information Management (HIM) staff in exporting and viewing individual reports in Galen (<https://elrio.vitalcenteronline.com/login/>) through the EPIC application.

**PROCEDURE:**

1. If a request for records is received a release in EPIC must be created (see standard operating procedure *HIM-002-SOP-ROI-017 Creating and Completing a NEW Release Request in Electronic Health Record (EHR)*) otherwise skip steps 1, 6, & 7, using steps 2-5 for viewing Galen records only.
2. Galen can be accessed as follows:
  - a. Select **Chart Central**
  - b. Double click on patient
  - c. Select **Chart Review** Tab
  - d. Select **Media** tab

# EL RIO HEALTH

<b>PROCEDURE DESCRIPTION:</b> Exporting and Viewing a Single Report in Galen	<b>REFERENCE NUMBER:</b> HIM-002-SOP-ROI-019
<b>PAGE:</b> 2 of 5	<b>EFFECTIVE DATE:</b>

e. Select **Hx EHR** tab

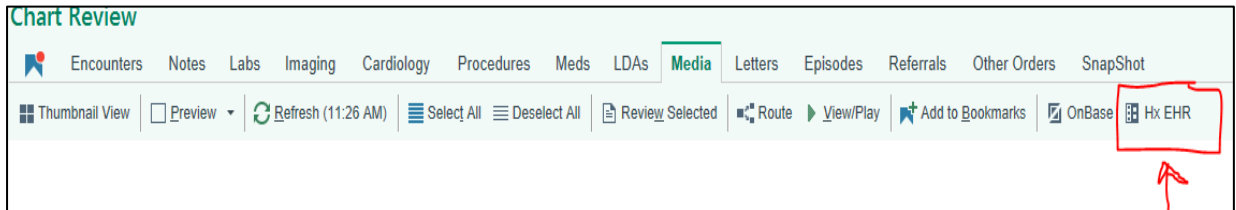

3. Galen will open in a separate browser (automatically logging you in) and patient's chart will display on the right-hand side displaying old EHR as follows\*\*:

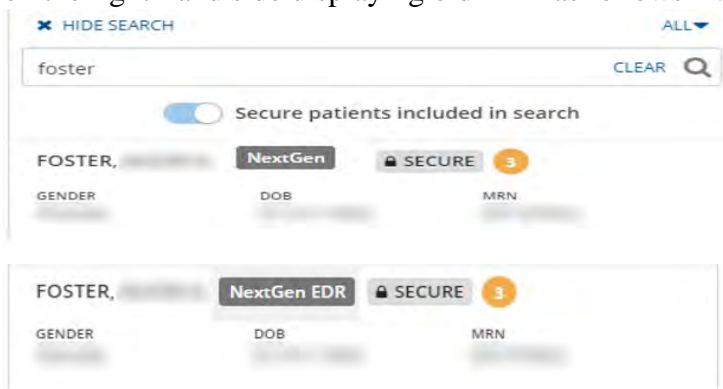

\*\*The Medical Chart will be associated with the **NextGen** button

\*\*The Dental Chart will be associated with the **NextGen EDR** button

4. Select patient's medical or dental chart by clicking on it so it is highlighted. The chart will now display on the left-hand side of Galen. If requestor is asking for multiple reports switch to standard operating procedure *HIM-002-SOP-ROI-018 Exporting Patient Data from Galen into EPIC's Release Template (Export Chart vs. Build an Export)*. **Export chart** allows you to select multiple individual categories or **Build an Export** allows you to select multiple individual documents. If requestor is asking for one specific report continue to step 5.

# EL RIO HEALTH

<b>PROCEDURE DESCRIPTION:</b> Exporting and Viewing a Single Report in Galen	<b>REFERENCE NUMBER:</b> HIM-002-SOP-ROI-019
<b>PAGE:</b> 3 of 5	<b>EFFECTIVE DATE:</b>

5. Once in the patient's chart use a→e to export one report:
  - a. Use the side navigational bar list of categories to locate document type

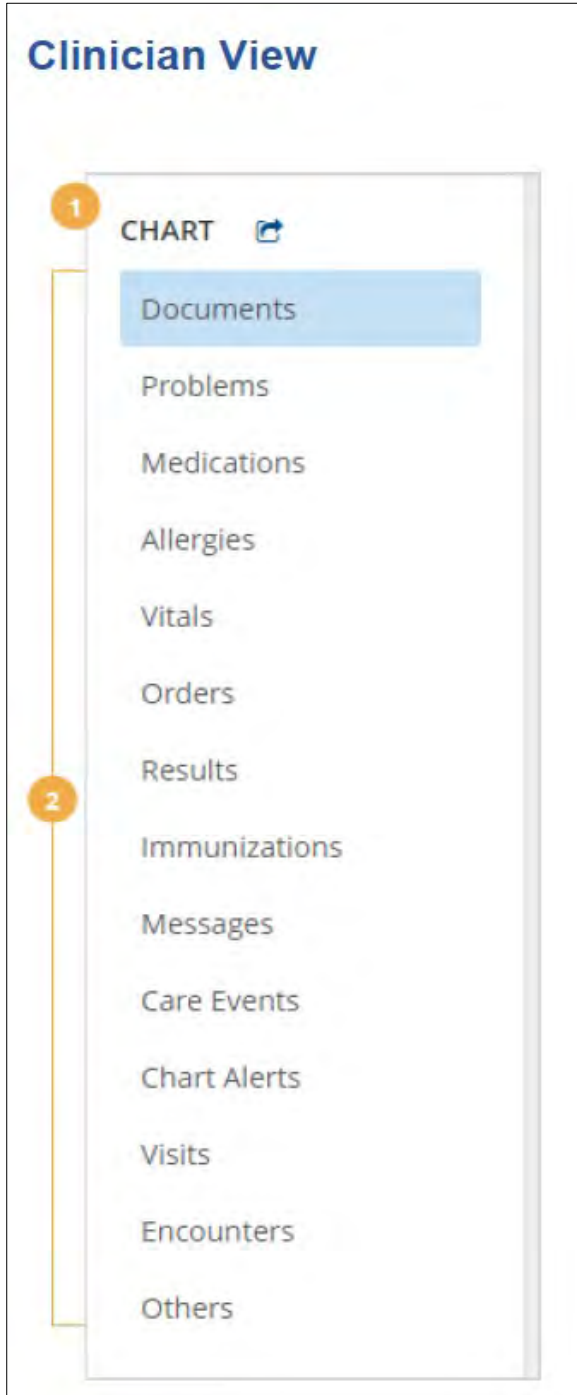

- b. Click on a section header category in the chart (example: immunizations/results/encounters)

# EL RIO HEALTH

<b>PROCEDURE DESCRIPTION:</b> Exporting and Viewing a Single Report in Galen	<b>REFERENCE NUMBER:</b> HIM-002-SOP-ROI-019
<b>PAGE:</b> 4 of 5	<b>EFFECTIVE DATE:</b>

- c. This will open a side panel allowing you to view a summary outline of documents in the selected category. Click on individual reports to view them.  
**Helpful Tip:** use filters to navigate charts containing a large amount of files.

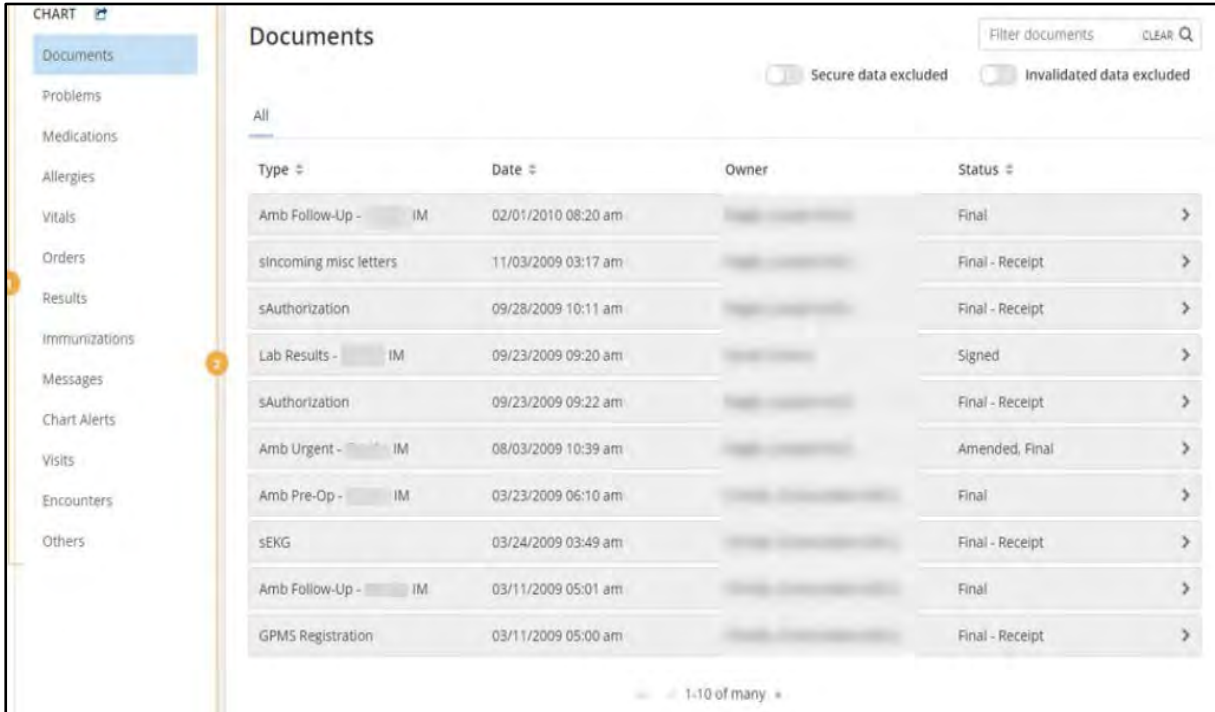

- d. Once the report that is needed is found: click  **EXPORT** button located at the top of the chart (a side bar will display on the right). Select **Export this** (*insert category name here*) as a PDF- some examples shown below:

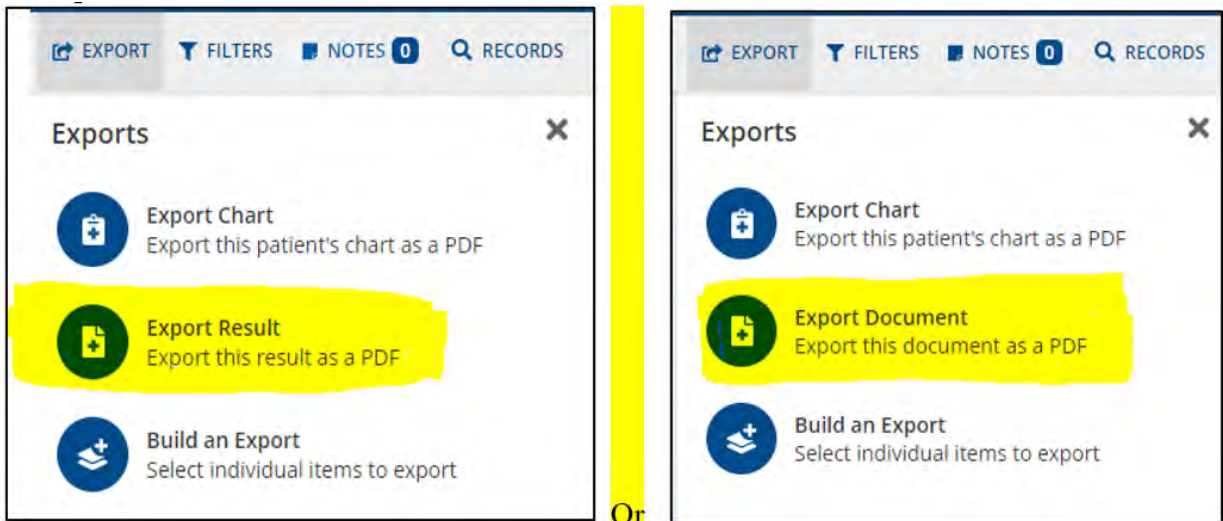

- e. The file will start to generate/ download. Click on downloaded document **in browser** to view.

# EL RIO HEALTH

<b>PROCEDURE DESCRIPTION:</b> Exporting and Viewing a Single Report in Galen	<b>REFERENCE NUMBER:</b> HIM-002-SOP-ROI-019
<b>PAGE:</b> 5 of 5	<b>EFFECTIVE DATE:</b>

6. If a release was created in step one: Save the file to the designated HIM area (computer/drive) in PDF format. Go back to your patient's Release of Information template located in EPIC.
7. In the output section of the release template:
  - a. Click **+ File** to insert
  - b. A window will populate so you may locate your saved Galen file (PDF)

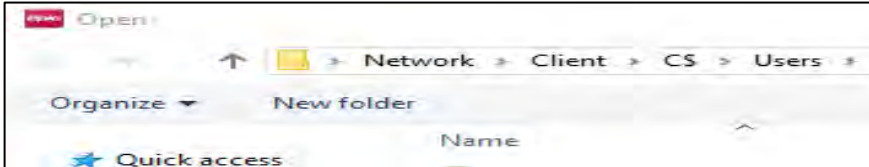

- c. Once saved file is located click **open** (located at the bottom right of window)

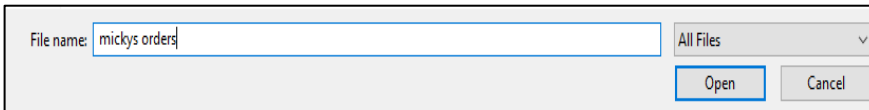

- d. Window will populate allowing you to change title name/description

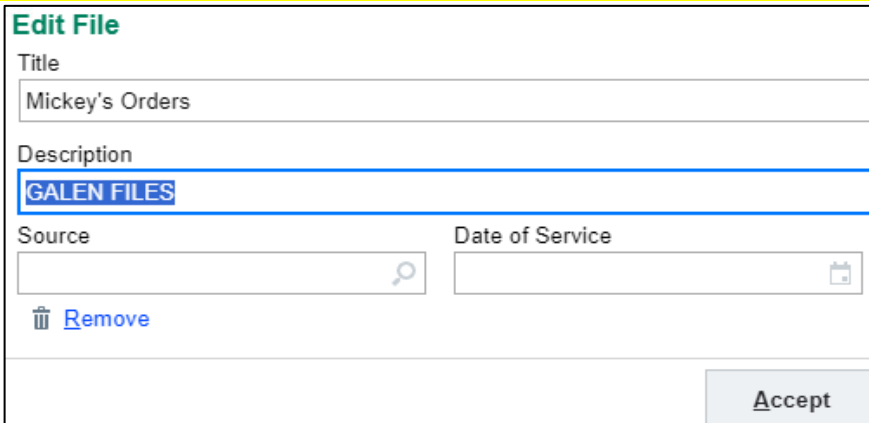

- e. Click **accept** to insert
  - f. When ready to print or fax out click deliver **in release template**. Reference standard operating procedure *HIM-002-SOP-ROI-017 Creating and Completing a NEW Release Request in Electronic Health Record (EHR)*.

## REFERENCES:

HIM-002-SOP-ROI-017 Creating and Completing a NEW Release Request in Electronic Health Record  
HIM-002-SOP-ROI-018 Exporting Patient Data from Galen into EPIC's Release Template (Export Chart vs. Build an Export).

# EL RIO HEALTH

**SCOPE:**

This Procedure applies to **CLINICAL** and **NON-CLINICAL** departments in the following El Rio Health functional areas and/or locations (check all that apply):

- |  |  |   |  |
|--|--|---|--|
| <input type="checkbox"/> Family Medicine   | <input type="checkbox"/> Same Day Appt. Clinic | <input type="checkbox"/> Radiology              | <input type="checkbox"/> MOR/DOS         |
| <input type="checkbox"/> Internal Medicine | <input type="checkbox"/> HOB/HOU               | <input type="checkbox"/> Pharmacy               | <input type="checkbox"/> Administration  |
| <input type="checkbox"/> Pediatrics        | <input type="checkbox"/> SIA                   | <input type="checkbox"/> Laboratory             | <input type="checkbox"/> Human Resources |
| <input type="checkbox"/> Dental            | <input type="checkbox"/> Care Coordination     | <input checked="" type="checkbox"/> HIM         | <input type="checkbox"/> Accounting      |
| <input type="checkbox"/> Behavioral Health | <input type="checkbox"/> Wellness              | <input type="checkbox"/> Information Technology | <input type="checkbox"/> Business Office |
| <input type="checkbox"/> Midwives          | <input type="checkbox"/> Clinical Pharmacy     | <input type="checkbox"/> Patient Communications | <input type="checkbox"/> Coding          |
| <input type="checkbox"/> OB/GYN            | <input type="checkbox"/> Facilities            | <input type="checkbox"/> Advocacy & Eligibility | <input type="checkbox"/> Security        |
| <input type="checkbox"/> Referrals         | <input type="checkbox"/> Purchasing            | <input type="checkbox"/> Physical Therapy       | <input type="checkbox"/> Transportation  |

<p><b>PROCEDURE DESCRIPTION:</b> Completing a Release of Information Request for Dental Reports and Imaging</p>	<p><b>PAGE:</b> 1 of 8</p>
	<p><b>REFERENCE NUMBER:</b> HIM-002-SOP-ROI-020</p>
<p><b>APPROVAL DATE:</b></p>	<p><b>DATES REVIEWED WITHOUT CHANGE:</b></p>
<p><b>EFFECTIVE DATE:</b></p>	<p><b>REPLACES PROCEDURE DATED:</b> 07/2023</p>
<p><b>NEXT REVIEW DATE:</b></p>	<p><b>DATE RETIRED:</b> N/A</p>
<p><b>RESPONSIBILITY:</b> HIM Management HIPAA Compliance Officer</p>	<p><b>APPROVALS:</b> PPC: CAC:</p>

**PURPOSE:** To assist Health Information Management (HIM)'s Release of Information team in obtaining dental imaging records through the XVCapture system to complete release of information requests. This standard operating procedure will include the release and tracking of dental reports and imaging in accordance with HIM-002-SOP-ROI-004 General Instructions for Completing a Release of Information Request Authorization.

# EL RIO HEALTH

<b>PROCEDURE DESCRIPTION:</b> Completing a Release of Information Request for Dental Reports and Imaging	<b>REFERENCE NUMBER:</b> HIM-002-SOP-ROI-020
<b>PAGE:</b> 2 of 8	<b>EFFECTIVE DATE:</b>

## PROCEDURE:

### Exporting Images from XVCapture:

1. Open up application **XVCapture** and click on **View Images** button



2. Search for patient using name or date of birth in designated boxes then select **Query for Images**

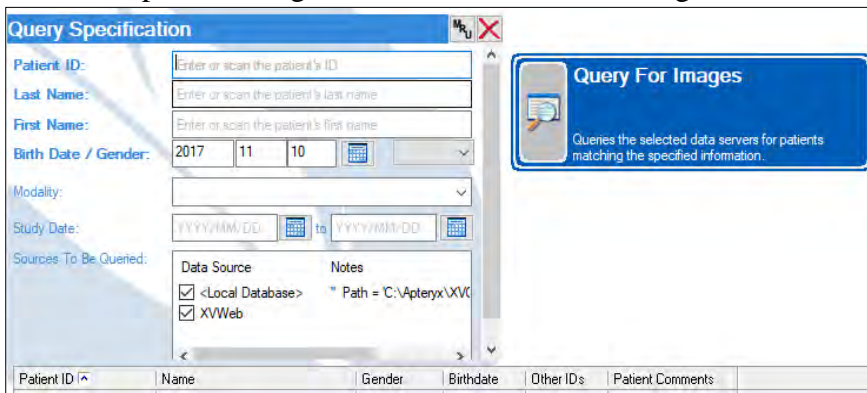

3. Locate study. Click the small **red** arrows next to the patient's ID number

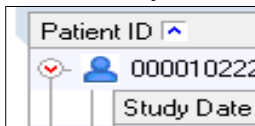

to view the following:

Study Date	Modalities	Accession Number	Study ID	Referring Doctor	Study Description	Study Instance UID

4. Click on study to highlight it and click on **View Study**

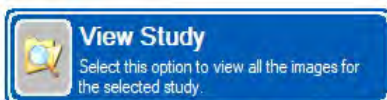

# EL RIO HEALTH

<b>PROCEDURE DESCRIPTION:</b> Completing a Release of Information Request for Dental Reports and Imaging	<b>REFERENCE NUMBER:</b> HIM-002-SOP-ROI-020
<b>PAGE:</b> 3 of 8	<b>EFFECTIVE DATE:</b>

5. Located on the left **side bar** Click on **Image Operations**:

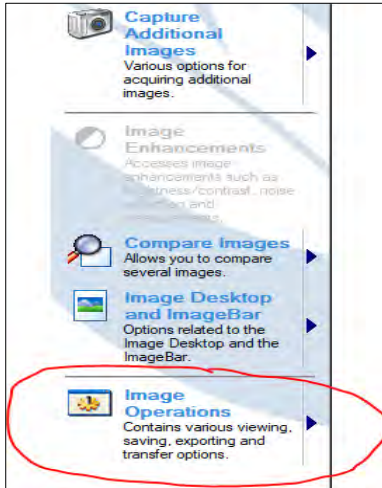

6. There are two options to extract images:

- a. Select the **Print Images** option. Print image to PDF by changing printer then editing the Multiple Print Format **section** accordingly. *Note: If there are more than 4 dental images select the option "contact sheet" and click print button at the bottom of the screen. See example below:*

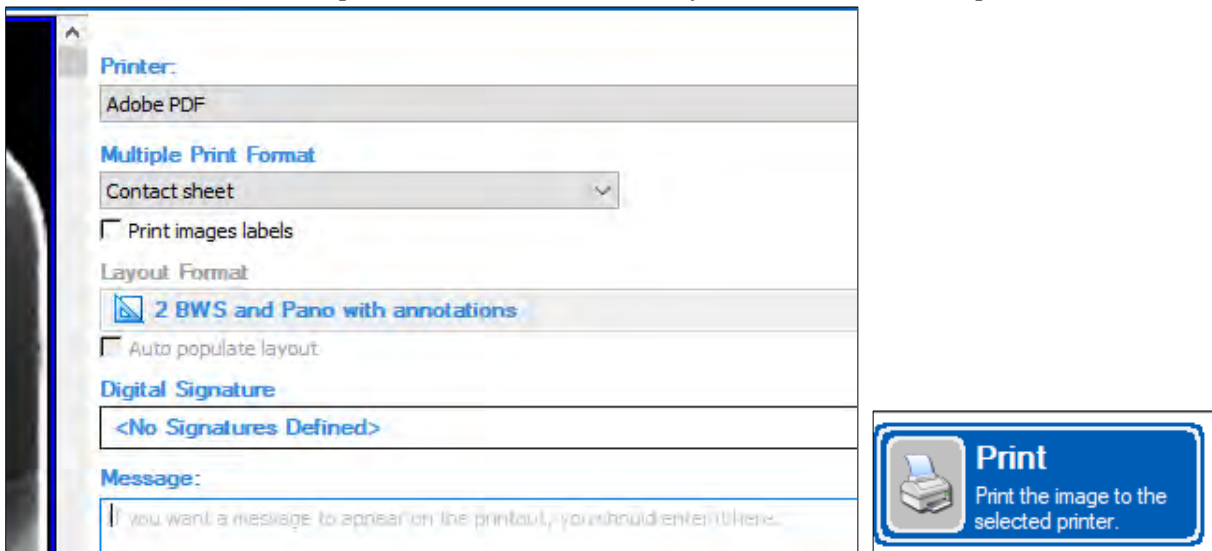

~~A Print Layout screen will then display for review. Click Print button located at bottom of screen.~~

A window should appear allowing you to save the file as a PDF. Here you can name the file and save it into a designated secured folder of the department's choosing.

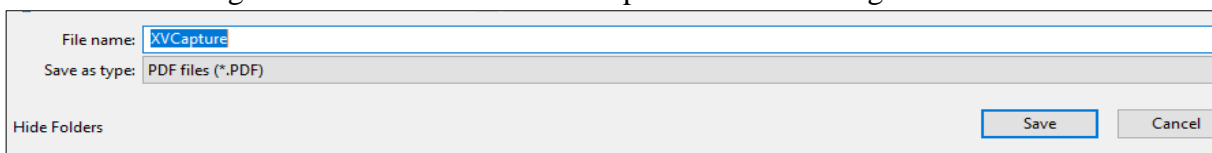

# EL RIO HEALTH

<b>PROCEDURE DESCRIPTION:</b> Completing a Release of Information Request for Dental Reports and Imaging	<b>REFERENCE NUMBER:</b> HIM-002-SOP-ROI-020
<b>PAGE:</b> 4 of 8	<b>EFFECTIVE DATE:</b>

- b. Save Image as a **JPG File** by selecting **Save and Export** then click **Save/Export Image**. A window will then populate for you to select a folder to save Image (Target Directory section below). Click **OK** to save image. The JPG file will now have all images selected saved in your folder.

## Prepare the release:

1. Create a release in the electronic medical record. Follow standard operating procedure HIM-002-SOP-ROI-017 Creating and Completing a NEW Release Request in Electronic Health Record
2. Remember to pull dental reports if requested: generating reports in release using the **Dental** selection in the ROI template

# EL RIO HEALTH

<b>PROCEDURE DESCRIPTION:</b> Completing a Release of Information Request for Dental Reports and Imaging	<b>REFERENCE NUMBER:</b> HIM-002-SOP-ROI-020
<b>PAGE:</b> 5 of 8	<b>EFFECTIVE DATE:</b>

3. Insert dental images obtained from XVCapture using the add (+)file button in Output section:

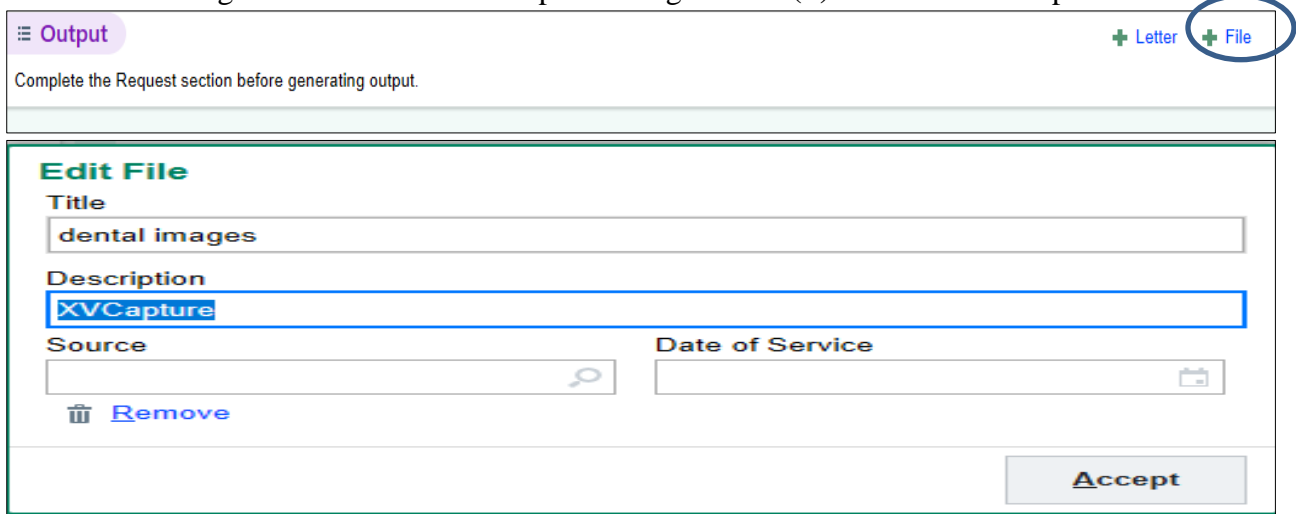

4. Generate and print files as a “print to PDF format” normal (see ~~HIM-002-SOP-ROI-017 Creating and Completing a NEW Release Request in Electronic Health Record~~) by selecting Deliver → Print → Print to PDF (Adobe PDF Printer selection)

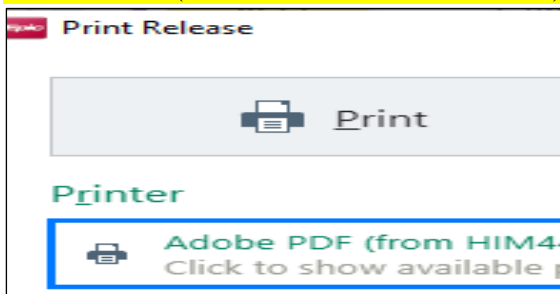

5. Under the Tracking part of the release: add password letter



6. Select letter from template drop down: HIM - ROI PASSWORD PROTECTED RECORDS



7. If records are to be mailed out letter wording is left as is (skip to step 8). If records are for someone who is currently waiting in-office replace the phrase “To obtain a password please contact El Rio HIM Department” with the actual password required to open records.

# EL RIO HEALTH

<b>PROCEDURE DESCRIPTION:</b> Completing a Release of Information Request for Dental Reports and Imaging	<b>REFERENCE NUMBER:</b> HIM-002-SOP-ROI-020
<b>PAGE:</b> 6 of 8	<b>EFFECTIVE DATE:</b>

8. Print letter and mail off with records (after export to CD is complete) using El Rio Health designated mail envelopes (or give to in-office requestor). Type a comment summarizing and include the CD password.

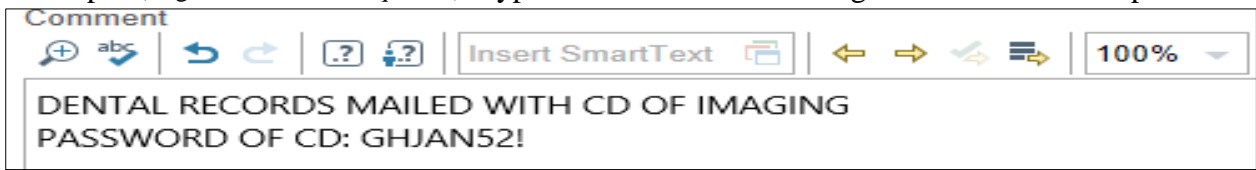

9. Complete the release by clicking the complete button at the bottom of the release.

### Export Document to CD:

1. Go to PDFs/Image files on your computer. Right click on the File: Select “7-Zip”
2. Choose “add to archive...” option
3. This will prompt a dialog box with options:  
 Archive Format = select “Zip” from the drop down  
 Enter Password = will have 5 Capital Letters plus two numbers and a “!” exclamation (see below):  
 first letter of patient’s first name (example: **K**elly)  
 first letter of patient’s last name (example: **S**mith)  
 three letter abbreviation for DOB month (example: **JAN**UARY)  
 last two numbers of birth year (example: 19**89**)  
 exclamation mark (!)
4. Select ok at the bottom of window

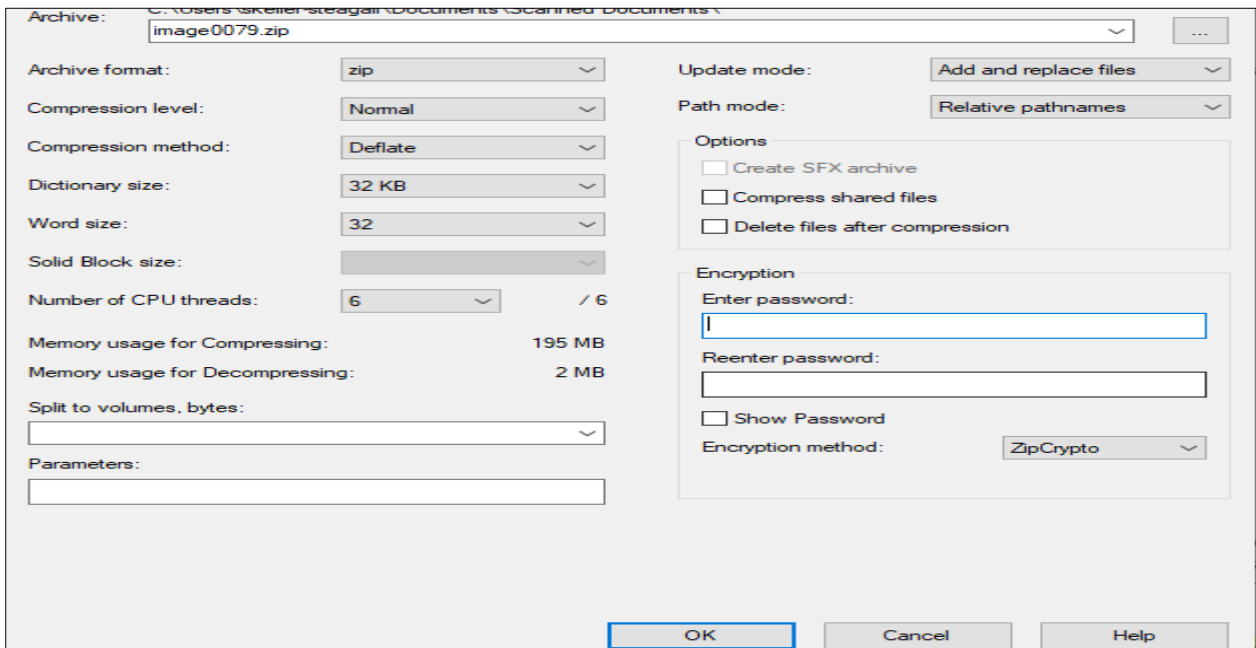

## EL RIO HEALTH

<b>PROCEDURE DESCRIPTION:</b> Completing a Release of Information Request for Dental Reports and Imaging	<b>REFERENCE NUMBER:</b> HIM-002-SOP-ROI-020
<b>PAGE:</b> 7 of 8	<b>EFFECTIVE DATE:</b>

5. A new folder will show as follows:

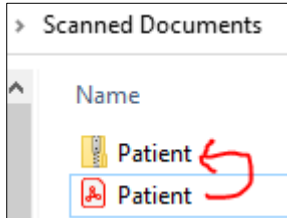

6. Double click on folder then double click on PDF: This PDF will now prompt a password to be imputed to continue.

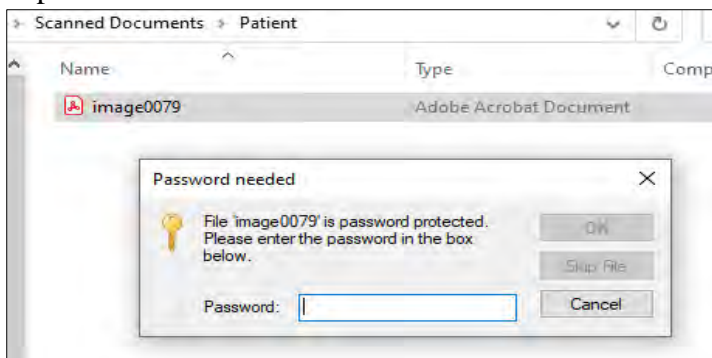

7. Verify previous created password does work:  
insert password and click ok → the Patient's records (PDF) should open  
*Quick Tip: If document does not open with password you may have to revisit step 3 and create a new zip file.*
8. Insert a blank CD into the Disk drive: the DVD drive should display under **This PC** on computer's drive
9. Drag the password protected file (or copy and paste) into the DVD drive
10. Right click in the DVD drive folder and select "burn to disk" option
11. Title disk: Patient's Last Name\_Dental then Click Next
12. A prompt should display "You have successfully burned your files to disc"
13. Click finish button → disk will pop out of computer
14. Double check: Re-insert the disk back into the computer and make sure it opens using the password
15. Write "El Rio Dental Records" and patient's name on the physical CD

# EL RIO HEALTH

<b>PROCEDURE DESCRIPTION:</b> Completing a Release of Information Request for Dental Reports and Imaging	<b>REFERENCE NUMBER:</b> HIM-002-SOP-ROI-020
<b>PAGE:</b> 8 of 8	<b>EFFECTIVE DATE:</b>

<b>REFERENCES:</b> HIM-002-SOP-ROI-017 Creating and Completing a NEW Release Request in Electronic Health Record HIM-002-SOP-ROI-004 General Instructions for Completing a Release of Information Request Authorization.
---

# EL RIO HEALTH

**SCOPE:**

This Procedure applies to **CLINICAL** and **NON-CLINICAL** departments in the following El Rio Health functional areas and/or locations (check all that apply):

- |  |  |   |  |
|--|--|---|--|
| <input type="checkbox"/> Family Medicine   | <input type="checkbox"/> Same Day Appt. Clinic | <input type="checkbox"/> Radiology              | <input type="checkbox"/> MOR/DOS         |
| <input type="checkbox"/> Internal Medicine | <input type="checkbox"/> HOB/HOU               | <input type="checkbox"/> Pharmacy               | <input type="checkbox"/> Administration  |
| <input type="checkbox"/> Pediatrics        | <input type="checkbox"/> SIA                   | <input type="checkbox"/> Laboratory             | <input type="checkbox"/> Human Resources |
| <input type="checkbox"/> Dental            | <input type="checkbox"/> Care Coordination     | <input checked="" type="checkbox"/> HIM         | <input type="checkbox"/> Accounting      |
| <input type="checkbox"/> Behavioral Health | <input type="checkbox"/> Wellness              | <input type="checkbox"/> Information Technology | <input type="checkbox"/> Business Office |
| <input type="checkbox"/> Midwives          | <input type="checkbox"/> Clinical Pharmacy     | <input type="checkbox"/> Patient Communications | <input type="checkbox"/> Coding          |
| <input type="checkbox"/> OB/GYN            | <input type="checkbox"/> Facilities            | <input type="checkbox"/> Advocacy & Eligibility | <input type="checkbox"/> Security        |
| <input type="checkbox"/> Referrals         | <input type="checkbox"/> Purchasing            | <input type="checkbox"/> Physical Therapy       | <input type="checkbox"/> Transportation  |

<b>PROCEDURE DESCRIPTION:</b> Operating Neopost Bulk Mailing Machine	<b>PAGE:</b> 1 of 4
	<b>REFERENCE NUMBER:</b> HIM-006-SOP-OM-006
<b>APPROVAL DATE:</b>	<b>DATES REVIEWED WITHOUT CHANGE:</b>
<b>EFFECTIVE DATE:</b>	<b>REPLACES PROCEDURE DATED:</b> 01/2021:HIM-001-SOP-MR-026 06/2022:12/2022
<b>NEXT REVIEW DATE:</b>	<b>DATE RETIRED:</b> N/A
<b>RESPONSIBILITY:</b> HIM Supervisor	<b>APPROVALS:</b> PPC: CAC:

**PURPOSE:** To guide Health Information Management (HIM) staff in operating Neopost machine for outgoing notices to patients via mail. **The HIM Neopost machine is located in the HIM department at the congress location.**

# EL RIO HEALTH

**PROCEDURE DESCRIPTION:**

Operating Neopost Bulk Mailing Machine

**REFERENCE NUMBER:**

HIM-006-SOP-OM-006

**PAGE:** 2 of 4**EFFECTIVE DATE:****PROCEDURE:**

1. Power ON Neopost machine.
2. Load the MAIN document onto the top tray of the three trays (area #1 in next picture). If there will be a second or third page added to the job, then add those documents to the second/third document feeder trays.

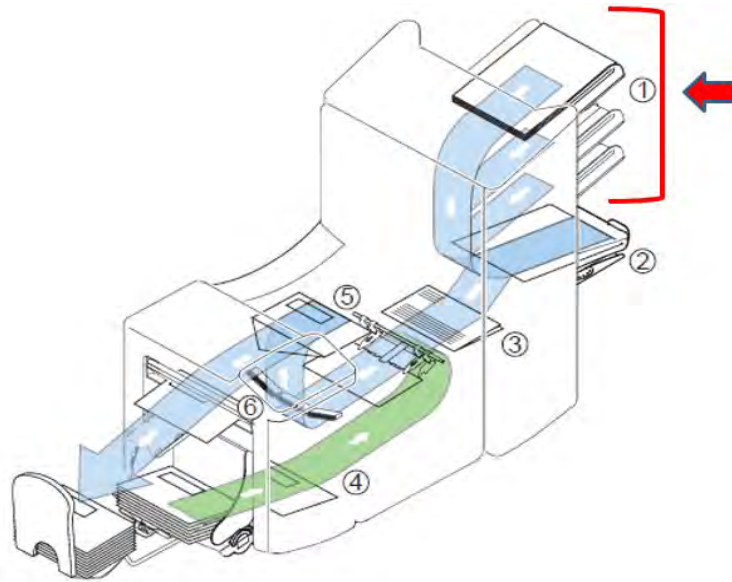

3. Load up blank envelopes on tray designated for envelopes (left side.) Face address window / logo upwards.

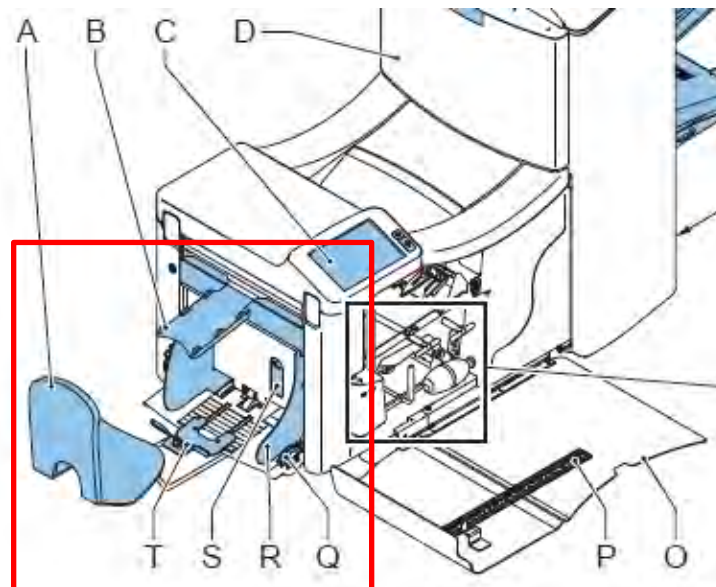

## EL RIO HEALTH

<b>PROCEDURE DESCRIPTION:</b> Operating Neopost Bulk Mailing Machine	<b>REFERENCE NUMBER:</b> HIM-006-SOP-OM-006
<b>PAGE:</b> 3 of 4	<b>EFFECTIVE DATE:</b>

4. Open cover (labeled (O) Side Cover) outwards to expose “Sealing Liquid Reservoir (N)”. Check if water level is full. If water is needed, fill reservoir to fill line. (Purified water only) **\*\*Outlined in green on step 4 there is a puffer labeled (L). Before every job, use (L) to puff some air (3 times) into the sensors labeled (K) through two circular holes. (no picture available).**

***Quick tip: You only need to puff air three times in the top sensor. It is not needed on the bottom sensor.***

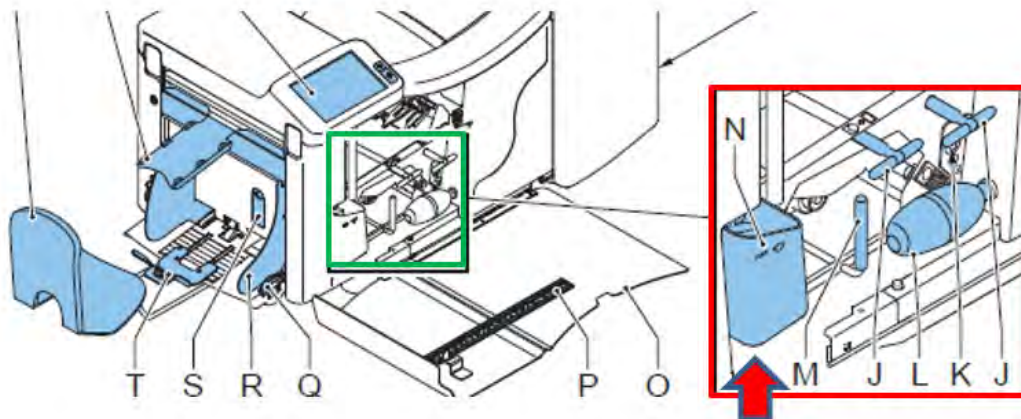

5. On the LCD (touchscreen) display, select the job you wish to perform for the documents on tray. If job descriptions do not match the job that is about to take place, then a new job must be created to fit the needs for the current job. This newly created job can be saved.

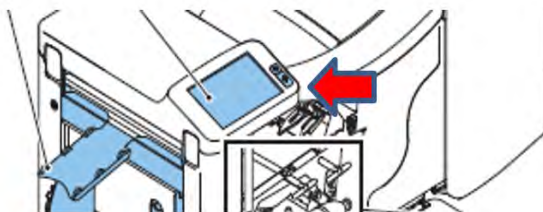

- The machine will ask if you wish to print entire job or if a test page should be run prior to full job initiates. This is your chance to check if the entire address line shows in the envelope window or if the machine is operating properly without any issues.

***Quick Tip for outgoing provider letters: Before you start printing make about 5 copies of the letter to put on the machine tray. Then you press the one time only selection so the letter enters the envelope, and you can see if the name and address fit in the window. If not, then you can make small adjustments as you go and run another test.***

- All settings can be configured within the LCD screen if desired. i.e., where the paper folds, type of fold, size of envelope that will be used etc. ***Example: you can set the counter to how many you want done before it stops to allow you to remove the sealed envelopes before continuing. It is currently set at 100 for easier counting.***\*\*\*

\*\*\*El Rio Health letters to patients are always “C” Fold (trifold) and #10 envelopes. \*\*\*

## EL RIO HEALTH

<b>PROCEDURE DESCRIPTION:</b> Operating Neopost Bulk Mailing Machine	<b>REFERENCE NUMBER:</b> HIM-006-SOP-OM-006
<b>PAGE:</b> 4 of 4	<b>EFFECTIVE DATE:</b>

6. Once “test envelope” (from step five) is verified to have no issues with folding or address line, press the “Start” button (green button) to proceed as normal.
  - If the machine gets a “paper / envelope jam” refer to service manual on article 7 **Fault Finding**. The service manual is located near the Neopost DS75i machine. It can also be in the “U” drive under [Neopost DS75i Service Manual](#)
  - For your own safety do not attempt to repair Neopost Machine. If a situation occurs alert a supervisor right away.
7. Print letter reports and place with finished letters in HIM designated area for transportation pickup.

**REFERENCES:** [Neopost DS75i Service Manual](#)

# EL RIO HEALTH

**SCOPE:**

This Procedure applies to **CLINICAL** and **NON-CLINICAL** departments in the following El Rio Health functional areas and/or locations (check all that apply):

- |   |   |  |   |
|---|---|--|---|
| <input checked="" type="checkbox"/> Family Medicine   | <input checked="" type="checkbox"/> Same Day Appt. Clinic | <input checked="" type="checkbox"/> Radiology              | <input checked="" type="checkbox"/> MOR/DOS         |
| <input checked="" type="checkbox"/> Internal Medicine | <input checked="" type="checkbox"/> HOB/HOU               | <input checked="" type="checkbox"/> Pharmacy               | <input checked="" type="checkbox"/> Administration  |
| <input checked="" type="checkbox"/> Pediatrics        | <input checked="" type="checkbox"/> SIA                   | <input checked="" type="checkbox"/> Laboratory             | <input checked="" type="checkbox"/> Human Resources |
| <input checked="" type="checkbox"/> Dental            | <input checked="" type="checkbox"/> Care Coordination     | <input checked="" type="checkbox"/> HIM                    | <input checked="" type="checkbox"/> Accounting      |
| <input checked="" type="checkbox"/> Behavioral Health | <input checked="" type="checkbox"/> Wellness              | <input checked="" type="checkbox"/> Information Technology | <input checked="" type="checkbox"/> Business Office |
| <input checked="" type="checkbox"/> Midwives          | <input checked="" type="checkbox"/> Clinical Pharmacy     | <input checked="" type="checkbox"/> Patient Communications | <input checked="" type="checkbox"/> Coding          |
| <input checked="" type="checkbox"/> OB/GYN            | <input type="checkbox"/> Facilities                       | <input checked="" type="checkbox"/> Advocacy & Eligibility | <input type="checkbox"/> Security                   |
| <input checked="" type="checkbox"/> Referrals         | <input type="checkbox"/> Purchasing                       | <input checked="" type="checkbox"/> Physical Therapy       | <input type="checkbox"/> Transportation             |

**PROCEDURE DESCRIPTION:**

Marking a Patient for a Potential Merge

**PAGE:**

1 of 3

**REFERENCE NUMBER:**

HIM-008-SOP-DI-001

**APPROVAL DATE:**

**DATES REVIEWED WITHOUT CHANGE:**

**EFFECTIVE DATE:**

**REPLACES PROCEDURE DATED:**

02/2023

**NEXT REVIEW DATE:**

**DATE RETIRED:**

N/A

**RESPONSIBILITY:**

Data Integrity Team  
HIM management Team

**APPROVALS:**

PPC:  
CAC:

**PURPOSE:** To assist Health Information Management (HIM) staff in identifying duplicate patient charts.

**PROCEDURE:**

- Click on search magnifying glass in the top Left corner of  drop down button. Type in the phrase “Mark” and a hyperlink will display to **Mark Patients for Merge**. Click on **Mark Patients for Merge**

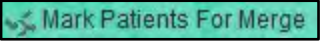
*Quick Tip:* You can pin the **Mark Patients for Merge** button to the  Menu dropdown or modify your settings to display the  button at the top of your screen for easy access.

- Select First Patient: use the patient search screen (see example below).

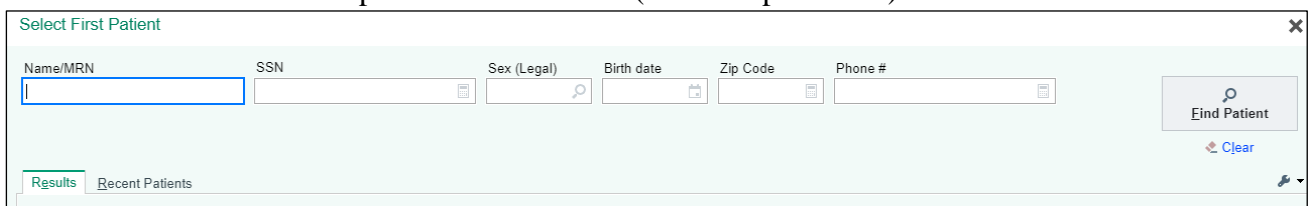

# EL RIO HEALTH

<b>PROCEDURE DESCRIPTION:</b> Marking a Patient for a Potential Merge	<b>REFERENCE NUMBER:</b> HIM-008-SOP-DI-001
<b>PAGE:</b> 2 of 3	<b>EFFECTIVE DATE:</b>

Once located click on patient

Patient Name	MRN	Patient St...	Sex	DOB
Testmychart, Mychart	50055858	Alive	F	1/1/2000

- Select second patient: Use the patient search screen (see example below).

**Select Second Patient** ✕

Name/MRN	SSN	Sex (Legal)	Birth date	Zip Code	Phone #
<input type="text"/>	<input type="text"/>	<input type="text"/>	<input type="text"/>	<input type="text"/>	<input type="text"/>

Once located click on patient

Patient Name	MRN	Patient St...	Sex	DOB
Chart, Test My	50102032	Alive	M	12/20/1985

- Both patients will display side by side: Compare information and click ✕ Cancel to abort or continue to step 5 to continue marking.

- If desired “keep” demographics are unknown skip to step 7 otherwise select most up-to-date patient information by clicking (highlighting) preferred demographics. These selections will appear darkened and update “your Recommendations” displayed in far-right column.

**Mark for Merge**

? To make recommendations for the demographic values to preserve in the merge, select the appropriate buttons in the first patient or second patient columns.

	First Patient	Second Patient	Your Recommendations
Name:	TESTMYCHART, MYCHAR T	CHART, TEST MY	TESTMYCHART, MYCHART
MRN:	50055858	50102032	50102032
Legal Sex:	Female	Male	Male
Birth Date:	01/01/2000	12/20/1985	01/01/2000
SSN:	000-00-0000	000-00-0000	000-00-0000
Registration Status:	New	New	New
Patient Status:	Alive	Alive	

Reason

Previously Unidentified Pa...

Comment

Parent created a new chart using his information instead of his daughters when scheduling an appointment. Both charts belong to her- conf DOB as 01.01.2000 verbally with patient

- Select reason option from drop-down using the magnifying glass provided

- Provide a detailed comment describing any relevant information that may assist El Rio Health HIM staff in completing this merge (details may include how you discovered these two charts are the same person). A detailed comment can be a time savor come decision and research time for health information management.

# EL RIO HEALTH

<b>PROCEDURE DESCRIPTION:</b> Marking a Patient for a Potential Merge	<b>REFERENCE NUMBER:</b> HIM-008-SOP-DI-001
<b>PAGE:</b> 3 of 3	<b>EFFECTIVE DATE:</b>

**8.** Click on mark for merge button. **You are now done.**

*The potential merge is now marked in Work queue "1787 Patients Marked for Merge" to be worked by assigned El Rio HIM staff. Only certain staff will have access to this work queue list. Follow up with the HIM department if you have any questions.*

Workqueue List - Potential Duplicates - Showing All Workqueues									
<span>Refresh</span>   <span>Open</span>   <span>Report</span>   <span>Export</span>   <span>Show All</span>   <span>New Filter</span>   <span>Evals</span>									
<span>Account</span>   <span>Charge Review</span>   <span>Chart Correction</span>   <span>Chart Correction Tool Runs</span>   <span>Claim Edit</span>   <span>CRM</span>   <span>External ID Bundle</span>   <span>Follow-up</span>   <span>Incoming Messages</span>   <span>Interface Errors</span>   <span>Overlays</span>   <span>Patient</span>   <span>Potential Duplicates</span>									
ID	Name	Service Area	Active Grouped Count	Active Ungrouped Count	Active	Last Accessed By	On	Description	Deferred Grouped C
★	1787 Patients Marked for Merge	El Rio Health Facility	9	9	Yes	GROLL, MARIAEDITH	12/26/2023	Patients marked for merge.	

**REFERENCES:**

# EL RIO HEALTH

**SCOPE:**

This procedure applies to **CLINICAL** and **NON-CLINICAL** departments in the following El Rio Health functional areas and/or locations (check all that apply):

- |   |   |   |  |
|---|---|---|--|
| <input checked="" type="checkbox"/> Family Medicine   | <input checked="" type="checkbox"/> Same Day Appt. Clinic | <input type="checkbox"/> Radiology              | <input type="checkbox"/> MOR/DOS         |
| <input checked="" type="checkbox"/> Internal Medicine | <input checked="" type="checkbox"/> HOB/HOU               | <input type="checkbox"/> Pharmacy               | <input type="checkbox"/> Administration  |
| <input checked="" type="checkbox"/> Pediatrics        | <input checked="" type="checkbox"/> SIA                   | <input type="checkbox"/> Laboratory             | <input type="checkbox"/> Human Resources |
| <input checked="" type="checkbox"/> Dental            | <input type="checkbox"/> Care Coordination                | <input type="checkbox"/> HIM                    | <input type="checkbox"/> Accounting      |
| <input checked="" type="checkbox"/> Behavioral Health | <input type="checkbox"/> Wellness                         | <input type="checkbox"/> Information Technology | <input type="checkbox"/> Business Office |
| <input checked="" type="checkbox"/> Midwives          | <input checked="" type="checkbox"/> Clinical Pharmacy     | <input type="checkbox"/> Patient Communications | <input type="checkbox"/> Coding          |
| <input checked="" type="checkbox"/> OB/GYN            | <input type="checkbox"/> Facilities                       | <input type="checkbox"/> Advocacy & Eligibility | <input type="checkbox"/> Security        |
| <input type="checkbox"/> Referrals                    | <input type="checkbox"/> Purchasing                       | <input type="checkbox"/> Physical Therapy       | <input type="checkbox"/> Transportation  |

<p><b>PROCEDURE DESCRIPTION:</b> Laboratory Specimen Labeling</p>	<p><b>PAGE:</b> 1 of 2</p>
	<p><b>REFERENCE NUMBER:</b> NUR-017-SOP-LS-001</p>
<p><b>APPROVAL DATE:</b></p>	<p><b>DATES REVIEWED WITHOUT CHANGE:</b></p>
<p><b>EFFECTIVE DATE:</b></p>	<p><b>REPLACES POLICY DATED:</b> 06/2019:04/2021:10/2022</p>
<p><b>NEXT REVIEW DATE:</b></p>	<p><b>DATE RETIRED:</b> N/A</p>
<p><b>RESPONSIBILITY:</b> Regional Health Center Directors</p>	<p><b>APPROVALS:</b> PPC: CAC:</p>

**PURPOSE:** To provide clinical staff with procedures for accurate labeling of lab specimens.

- PROCEDURE:**
1. Each specimen will be labeled with printed lab specimen label(s) with patient’s identification information (name and DOB at the minimum).
  2. All patient printed lab specimen label(s) s should be printed before entering the patient’s exam room and verified by asking the patient their name and date of birth.
  3. Have the patient initial the label before proceeding with specimen collection.
  4. Gloves need to be worn by staff during specimen collection.
  5. Each specimen will be labeled with the date and time collected.

## EL RIO HEALTH

<b>PROCEDURE DESCRIPTION:</b> Laboratory Specimen Labeling	<b>REFERENCE NUMBER:</b> NUR-017-SOP-LS-001
<b>PAGE:</b> 2 of 2	<b>EFFECTIVE DATE:</b>

6. After specimen is collected, verify with patient again that label has the correct patient's name and date of birth.
7. Place patient's initialed lab specimen labels on specimen container and insert into specimen bag. in front of patient before removing specimen from room.
8. For specimens collected by a provider, the labels should be initialed by the patient prior to specimen collection. If the nursing staff is in the room at the time of specimen collection, they may apply the patient initialed label to the specimen. If the nursing staff is not in the room at the time of specimen collection, the provider must apply the label to the specimen.
9. Wipe the transport bag with a clinically approved COVID-19 disinfectant if contamination of bag is suspected.
10. Remove (doff) and discard Personal Protective Equipment used.
11. Perform hand hygiene.
12. For a POCT test such as blood glucose, in which a container is not used, still print a visit label, have the patient initial it and obtain the specimen. Use the label to enter the patient CSN into the device.
13. The laboratory will not order or process any lab order or specimen missing collection type written on and specimen.
14. All specimens must be delivered to the laboratory as soon as possible after collection.

### REFERENCES:

[El Rio Laboratory Policy and Procedures located on SharePoint](#)

# EL RIO HEALTH

**SCOPE:**

This standing order applies to **CLINICAL** and **NON-CLINICAL** departments in the following El Rio Health functional areas and/or locations (check all that apply):

- |   |   |   |  |
|---|---|---|--|
| <input checked="" type="checkbox"/> Family Medicine   | <input checked="" type="checkbox"/> Same Day Appt. Clinic | <input checked="" type="checkbox"/> Radiology   | <input type="checkbox"/> MOR/DOS         |
| <input checked="" type="checkbox"/> Internal Medicine | <input checked="" type="checkbox"/> HOB/HOU               | <input type="checkbox"/> Pharmacy               | <input type="checkbox"/> Administration  |
| <input checked="" type="checkbox"/> Pediatrics        | <input checked="" type="checkbox"/> SIA                   | <input type="checkbox"/> Laboratory             | <input type="checkbox"/> Human Resources |
| <input type="checkbox"/> Dental                       | <input type="checkbox"/> Care Coordination                | <input type="checkbox"/> HIM                    | <input type="checkbox"/> Accounting      |
| <input type="checkbox"/> Behavioral Health            | <input type="checkbox"/> Wellness                         | <input type="checkbox"/> Information Technology | <input type="checkbox"/> Business Office |
| <input checked="" type="checkbox"/> Midwives          | <input checked="" type="checkbox"/> Clinical Pharmacy     | <input type="checkbox"/> Patient Communications | <input type="checkbox"/> Coding          |
| <input checked="" type="checkbox"/> OB/GYN            | <input type="checkbox"/> Facilities                       | <input type="checkbox"/> Advocacy & Eligibility | <input type="checkbox"/> Security        |
| <input type="checkbox"/> Referrals                    | <input type="checkbox"/> Purchasing                       | <input type="checkbox"/> Physical Therapy       | <input type="checkbox"/> Transportation  |

<b>STANDING ORDER DESCRIPTION:</b> Standing Order for Breast Cancer Screening	<b>PAGE:</b> 1 of 2
	<b>REFERENCE NUMBER:</b> NUR-024-SOP-SO-015
<b>APPROVAL DATE:</b>	<b>DATES REVIEWED WITHOUT CHANGE:</b>
<b>EFFECTIVE DATE:</b>	<b>REPLACES POLICY DATED:</b> 10/2020:10/2021:11/2022
<b>NEXT REVIEW DATE:</b> (ANNUAL)	<b>DATE RETIRED:</b> N/A
<b>RESPONSIBILITY:</b> Medical Directors Regional Health Center Directors Radiology Manager	<b>APPROVALS:</b> PPC: CAC:
	<b>Authorized by Chief Clinical Officer (CCO):</b>

**PURPOSE:** To provide the El Rio staff with a standing order for the following:

- 1) To allow clinical staff to order a screening mammogram for appropriate patients according to protocol.
- 2) To allow radiology staff to notify patients by mail of normal results and call patients to schedule all cases that are abnormal and that require additional testing.
- 3) To allow radiology staff to convert exams from screening to diagnostic if the patient voices new complaints of breast pain/mass that was not previously disclosed to the Primary Care Provider.

**PROCEDURE:**

1. Identify patients who meet breast cancer screening care gap.
2. Inclusion/Exclusion Criteria to Order Screening Mammogram by Nursing staff:
  - a. The patient must be an established El Rio patient between the ages of 50-74-years of age with mature breast tissue.

# EL RIO HEALTH

<b>STANDING ORDER DESCRIPTION:</b> Standing Orders Breast Cancer Screening	<b>REFERENCE NUMBER:</b> NUR-024-SOP-SO-015
<b>PAGE:</b> 2 of 2	<b>EFFECTIVE DATE:</b>

- b. The patient must **not** have a history of breast cancer within the past ~~three~~ **five** (3 5) years, or an abnormal mammogram in the past year.
  - c. The patient must **not** be pregnant.
  - d. The patient must **not** have a current history of breast complaints i.e., mass or nipple discharge
  - e. The patient must **not** have had a mammogram within the last two (2) years unless otherwise determined by the provider.
3. Use Bilateral Screening Mammogram order.
    - Do not use Reason for Exam with spyglass options.
    - Enter “screening for breast cancer” in the Reason for Exam (Free Text) space
    - Spyglass hard stop will disappear
  4. Scheduling Appointments
    - All efforts should be made to make an appointment for an exam for the patient before the patient leaves the office.
  5. Radiology Department Notification of Patient Results
    - a. Radiology Staff notifies all patients by mail with their mammogram results whether they are normal or require a follow up, or a biopsy.
    - b. Radiology Staff calls all patients with abnormal exams or short-term follow up exams requiring additional views or testing to schedule the exam per Radiology policy & procedure. Radiology Staff enters proper documentation within the patient’s Electronic Health Record (EHR).
  6. Radiology Department Conversion of screening exam to diagnostic exam
    - a. All patients are screened by radiology staff for new onset breast mass or discharge prior to screening mammogram.
    - b. If any patient voices concern of new breast symptoms at the time of the screening exam, Radiology Staff converts the screening exam to the appropriate diagnostic exam and informs the Primary Care Provider. For any Well-Women Patients expressing concerns we will message the provider for clarification. Radiology cannot convert a screening to diagnostic for any Well-women patients.
    - c. Radiology Staff enters proper documentation within the patient’s EHR

## REFERENCES:

Center of Disease Control and Prevention, Breast Cancer; What is Breast Cancer Screening? Last reviewed ~~September 14, 2020.~~ **July 25, 2023.**

[https://www.cdc.gov/cancer/breast/basic\\_info/screening.htm](https://www.cdc.gov/cancer/breast/basic_info/screening.htm)

U.S. Preventive Services Taskforce, Breast Cancer Screening, released date; January 2016. Viewed ~~August 31, 2021.~~ **October 31, 2023.**

<https://www.uspreventiveservicestaskforce.org/Page/Document/RecommendationStatementFinal/breast-cancer-screening1>

# EL RIO HEALTH

**SCOPE:**

This standing order applies to **CLINICAL** and **NON-CLINICAL** departments in the following El Rio Health functional areas and/or locations (check all that apply):

- |   |   |   |  |
|---|---|---|--|
| <input checked="" type="checkbox"/> Family Medicine   | <input checked="" type="checkbox"/> Same Day Appt. Clinic | <input type="checkbox"/> Radiology              | <input type="checkbox"/> MOR / DOS       |
| <input checked="" type="checkbox"/> Internal Medicine | <input checked="" type="checkbox"/> HOB/HOU               | <input checked="" type="checkbox"/> Pharmacy    | <input type="checkbox"/> Administration  |
| <input checked="" type="checkbox"/> Pediatrics        | <input checked="" type="checkbox"/> SIA                   | <input type="checkbox"/> Laboratory             | <input type="checkbox"/> Human Resources |
| <input type="checkbox"/> Dental                       | <input type="checkbox"/> Care Coordination                | <input type="checkbox"/> HIM                    | <input type="checkbox"/> Accounting      |
| <input type="checkbox"/> Behavioral Health            | <input type="checkbox"/> Wellness                         | <input type="checkbox"/> Information Technology | <input type="checkbox"/> Business Office |
| <input checked="" type="checkbox"/> Midwives          | <input checked="" type="checkbox"/> Clinical Pharmacy     | <input type="checkbox"/> Patient Communications | <input type="checkbox"/> Coding          |
| <input checked="" type="checkbox"/> OB/GYN            | <input type="checkbox"/> Facilities                       | <input type="checkbox"/> Advocacy & Eligibility | <input type="checkbox"/> Security        |
| <input type="checkbox"/> Referrals                    | <input type="checkbox"/> Purchasing                       | <input type="checkbox"/> Physical Therapy       | <input type="checkbox"/> Transportation  |

**STANDING ORDER DESCRIPTION:**  
Standing Order for the Administration of **COMIRNATY** for 12 years of age and older

**PAGE:**  
1 of 13

**REFERENCE NUMBER:**  
NUR-024-SOP-SO-041-A (unretired)

**APPROVAL DATE:**

**DATES REVIEWED WITHOUT CHANGE:**

**EFFECTIVE DATE:**

**REPLACES POLICY DATED:**  
04/2022:09/2022:10/2022: 09/2023

**NEXT REVIEW DATE:**  
(ANNUAL)

**DATE RETIRED:**

**RESPONSIBILITY:**  
Medical Directors  
Regional Health Center Directors

**APPROVALS:**  
PS&T:  
PPC:  
CAC:

**AUTHORIZED By: Chief Clinical Officer:**

**PURPOSE:** To reduce the morbidity and mortality of the SARS-CoV-2 virus by vaccinating adults and adolescents 12 years of age and older. ~~Under~~ This standing order allows licensed nursing staff and medical assistants to order and may vaccinate both established and non-established individuals who are 12 years of age and older and who meet the criteria below with the **COMIRNATY** (COVID-19 Vaccine, mRNA) (2023-2024 Formula).

**PROCEDURE:**

COMIRNATY (COVID-19 Vaccine, mRNA) (2023-2024 Formula) will be offered to El Rio Health Employees and both established patients and non-established individuals who are who are 12 years of age and older.

# EL RIO HEALTH

<b>STANDING ORDER DESCRIPTION:</b> Standing Order for the Administration of Pfizer-BioNTech/COMIRNATY COVID-19 Vaccine	<b>REFERENCE NUMBER:</b> NUR-024-SOP-SO-041-A
<b>PAGE:</b> 2 of 16	<b>EFFECTIVE DATE:</b>

**NOTE:** Non-established individuals will be registered in the El Rio Electronic Health Record system. Refer to [NUR-024-SOP-SO-027 Standing Order: Walk-in Influenza and Immunizations](#).

1. Determine persons in need of vaccination against the SARS-CoV-2 virus based on the following criteria
  - a. Must be 12 years of age and older
  - b. People ages 12 years and older who are unvaccinated or previously received any number of Original monovalent or bivalent mRNA vaccine doses are recommended to receive 1 dose of an updated (2023–2024 Formula) mRNA vaccine from either manufacturer.
  - c. People ages 12 years and older who previously received 1 or more doses of Novavax COVID-19 Vaccine or Janssen COVID-19 Vaccine, including those who also received any mRNA vaccine dose(s), are recommended to receive 1 dose of an updated (2023–2024 Formula) mRNA vaccine from either manufacturer.
  - d. People ages 65 years and older are recommended to receive 1 dose of updated (2023–2024 Formula) mRNA vaccine; an additional dose of COVID-19 vaccine is not recommended at this time.
  - e. People ages 5 years and older who are moderately or severely immunocompromised should receive a 3-dose initial vaccination series using vaccines from the same manufacturer. Refer to **Step 8: Individuals 12 Years of Age and Older with Certain Kinds of Immunocompromise see Table 1.**
  - f. In the following exceptional situations, a different age-appropriate COVID-19 vaccine may be administered:
    - 1) Same vaccine not available
    - 2) Previous dose unknown
    - 3) Person would otherwise not complete the vaccination series
    - 4) Person starts but unable to complete a vaccination series with the same COVID-19 vaccine due to a contraindication
  - g. Vaccination of persons with known current SARS-CoV-2 (COVID-19) infection should be deferred until they have recovered from the acute illness (10 days after a positive COVID 19 test or twenty-four (24) hours symptom free, whichever is greater) AND criteria have been met for them to discontinue isolation. Vaccination may be deferred for 3 months for patients/employees at low risk for reinfection or severe disease.
2. Screen eligible persons for contraindications and precautions for the SARS-CoV-2 vaccine.
  - a. **Contraindications:**
    - 1) Under 12 years of age
    - 2) Do not administer COMIRNATY to individuals with known history of a severe allergic reaction (e.g., anaphylaxis) to any component of COMIRNATY or to individuals who had a severe allergic reaction (e.g., anaphylaxis) following a previous dose of a Pfizer-BioNTech COVID-19 vaccine.

# EL RIO HEALTH

<b>STANDING ORDER DESCRIPTION:</b> Standing Order for the Administration of Pfizer-BioNTech/ <b>COMIRNATY</b> COVID-19 Vaccine	<b>REFERENCE NUMBER:</b> NUR-024-SOP-SO-041-A
<b>PAGE:</b> 3 of 16	<b>EFFECTIVE DATE:</b>

**b. Precautions:**

- 1) Acute Allergic reactions
- 2) Myocarditis and Pericarditis
- 3) Syncope (fainting) may occur in association with administration of injectable vaccines, in particular in adolescents. Procedures should be in place to avoid injury from fainting.
- 4) Immunocompromised persons, including individuals receiving immunosuppressant therapy, may have a diminished immune response.

**3. Provide the following information:**

- a. Patient Package Insert for COMIRNATY (COVID-19 Vaccine, mRNA) (2023-2024 Formula Information for Recipients and Caregivers (See Attachment A)
- b. Informed consent for employee / patient to sign. If patient is a minor, have the parent / guardian sign the consent.
- c. Provide a vaccination card to the recipient or their caregiver with date of vaccination, product name/manufacturer, lot number, and name/location of the health center and staff administering vaccine. For individuals with certain kinds of immunocompromise, include the date when the recipient needs to return for the second dose of COMIRNATY (COVID-19 Vaccine, mRNA) **(2023-2024 Formula)**.

**4. Vaccine Preparation for Administration:**

- a. **COMIRNATY** (COVID-19 Vaccine, mRNA). is supplied in either a single dose vial, **single dose prefilled glass syringe or single dose prefilled plastic syringe** with **gray caps and labels with gray matching borders**

# EL RIO HEALTH

<b>STANDING ORDER DESCRIPTION:</b> Standing Order for the Administration of Pfizer-BioNTech/COMIRNATY COVID-19 Vaccine	<b>REFERENCE NUMBER:</b> NUR-024-SOP-SO-041-A
<b>PAGE:</b> 4 of 16	<b>EFFECTIVE DATE:</b>

## Identifying vials of COMIRNATY® (COVID-19 Vaccine, mRNA)

Verify the vials (including labels) prior to preparation and administration to help avoid vaccine administration errors

<b>Name</b>	<b>COMIRNATY® (COVID-19 Vaccine, mRNA) 2023-2024 Formula</b> Single Dose Vial <b>DO NOT DILUTE</b>
<b>Composition</b>	Each 0.3 mL dose is formulated to contain 30 mcg of modRNA encoding Omicron variant lineage XBB.1.5 (Omicron XBB.1.5).
<b>Age Group</b>	12 years and older
<b>Cap Color &amp; Label</b> <i>Cap colors and labels with matching borders</i>  <b>Verify vial label states "2023-2024 Formula"</b>	<div style="display: flex; align-items: center; justify-content: center;"> <div style="margin-right: 10px;">Gray</div>  </div>
<b>NDC Codes</b>	<b>Single Dose Vial:</b> 0069-2362-01 <b>Carton of 10 single dose vials:</b> 0069-2362-10

Verify the prefilled syringes (including labels) prior to preparation and administration to help avoid vaccine administration errors

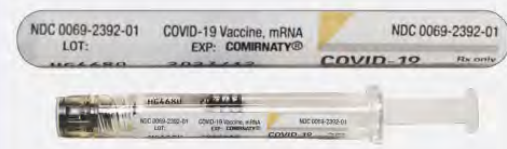
	<b>COMIRNATY® (COVID-19 Vaccine, mRNA) 2023-2024 Formula</b> <b>GLASS SINGLE DOSE PREFILLED SYRINGE<sup>a</sup></b>	<b>COMIRNATY® (COVID-19 Vaccine, mRNA) 2023-2024 Formula</b> <b>PLASTIC SINGLE DOSE PREFILLED SYRINGE<sup>a</sup></b>
<b>Name</b>	<b>COMIRNATY® (COVID-19 Vaccine, mRNA) 2023-2024 Formula</b> GLASS SINGLE DOSE PREFILLED SYRINGE <sup>a</sup>	<b>COMIRNATY® (COVID-19 Vaccine, mRNA) 2023-2024 Formula</b> PLASTIC SINGLE DOSE PREFILLED SYRINGE <sup>a</sup>
<b>Composition</b>	Each 0.3 mL dose is formulated to contain 30 mcg of modRNA encoding Omicron variant lineage XBB.1.5 (Omicron XBB.1.5).	Each 0.3 mL dose is formulated to contain 30 mcg of modRNA encoding Omicron variant lineage XBB.1.5 (Omicron XBB.1.5).
<b>Age Group</b>	12 years and older	12 years and older
<b>Verify syringe label states "2023-2024 Formula"</b>		
<b>NDC Codes</b>	<b>Single Dose Prefilled Syringe:</b> 0069-2377-01 <b>Carton of 10 Single Dose Prefilled Syringes:</b> 0069-2377-10	<b>Single Dose Prefilled Syringe:</b> 0069-2392-01 <b>Carton of 10 Single Dose Prefilled Syringes:</b> 0069-2392-10

# EL RIO HEALTH

<b>STANDING ORDER DESCRIPTION:</b> Standing Order for the Administration of Pfizer-BioNTech/COMIRNATY COVID-19 Vaccine	<b>REFERENCE NUMBER:</b> NUR-024-SOP-SO-041-A
<b>PAGE:</b> 5 of 16	<b>EFFECTIVE DATE:</b>

## b. COMIRNATY Single Dose Vials

- 1) Verify that the vial states 2023-2024 Formula.
- 2) Thaw vial in the refrigerator [2°C to 8°C (35°F to 46°F)] or at room temperature [up to 25°C (77°F)].
- 3) Prior to use, mix by inverting vial gently 10 times. Do not shake.
- 4) Withdraw a single 0.3 mL dose using a sterile needle and syringe.
- 5) Discard vial and any excess volume.

## c. COMIRNATY Single Dose Glass Prefilled Syringes

- 1) If glass prefilled syringe has been frozen, discard.
- 2) Do not shake.
- 3) Remove tip cap by slowly turning the cap counterclockwise while holding the Luer lock and attach a sterile needle.
- 4) The glass prefilled syringe should be used immediately. If it cannot be used immediately, it must be used within 4 hours.

## d. COMIRNATY Single Dose Plastic Prefilled Syringes

- 1) If syringes are frozen, thaw syringe in the carton in the refrigerator [2°C to 8°C (35°F to 46°F)] or at room temperature [up to 25°C (77°F)]. Do not remove syringe from carton to thaw.
- 2) Do not shake.
- 3) Remove tip cap and attach a sterile needle
- 4) If it cannot be used immediately, it must be used within 4 hours.

## e. How Vaccine is Supplied/Storage Prior to Use:

COMIRNATY is a suspension for intramuscular injection. Confirm the appropriate storage condition using the NDC number for the presentations supplied as follows:

### 1) Glass Prefilled Syringes (NDC 0069-2377)

- a) Carton of 10 single dose prefilled syringes: NDC 0069-2377-10
- b) Single dose prefilled syringe: NDC 0069-2377-01
- c) may be stored at 2°C to 8°C (35°F to 46°F) until the expiration date printed on the carton and syringe labels.
- d) DO NOT FREEZE
- e) The total time out of refrigeration (at temperatures between 8°C and 25°C (46°F and 77°F)) must not exceed 12 hours.

### 2) Plastic Prefilled Syringes (NDC 0069-2392)

- a) Carton of 10 single dose prefilled syringes: NDC 0069-2392-10
- b) Single dose prefilled syringe: NDC 0069-2392-01
- c) COMIRNATY plastic prefilled syringes (NDC 0069-2392) may arrive frozen at ultra-cold conditions in thermal containers with dry ice. Once received,

# EL RIO HEALTH

<b>STANDING ORDER DESCRIPTION:</b> Standing Order for the Administration of Pfizer-BioNTech/COMIRNATY COVID-19 Vaccine	<b>REFERENCE NUMBER:</b> NUR-024-SOP-SO-041-A
<b>PAGE:</b> 6 of 16	<b>EFFECTIVE DATE:</b>

frozen plastic prefilled syringes may be immediately transferred to the refrigerator at 2°C to 8°C (35°F to 46°F), thawed and stored for up to 10 weeks. The 10-week refrigerated expiry date should be recorded on the carton at the time of transfer. Cartons of 10 single dose plastic prefilled syringes may take up to 2 hours to thaw at this temperature. Once thawed, they should not be refrozen.

- d) Alternatively, frozen plastic prefilled syringes may be stored in an ultra-low temperature freezer at -90°C to -60°C (-130°F to -76°F). Do not store vials and prefilled syringes at -25°C to -15°C (-13°F to 5°F).
- e) Cartons of COMIRNATY plastic prefilled syringes may be received at 2°C to 8°C (35°F to 46°F), and they should be stored at 2°C to 8°C (35°F to 46°F). Check that the carton has been previously updated to reflect the 10-week refrigerated expiry date.
- f) The total time out of refrigeration (at temperatures between 8°C and 25°C (46°F and 77°F)) must not exceed 12 hours.

### 3) Vials (NDC 0069-2362)

- a) Carton of 10 single dose vials: NDC 0069-2362-10
- b) Single dose vial: NDC 0069-2362-01
- c) COMIRNATY single dose vials (NDC 0069-2362) may arrive frozen at ultra-cold conditions in thermal containers with dry ice. Once received, frozen vials may be immediately transferred to the refrigerator at 2°C to 8°C (35°F to 46°F), thawed and stored for up to 10 weeks. The 10-week refrigerated expiry date should be recorded on the carton at the time of transfer. Cartons of 10 single dose vials may take up to 2 hours to thaw at this temperature. Once thawed, they should not be refrozen.
- d) Alternatively, frozen single dose vials may be stored in an ultra-low temperature freezer at -90°C to -60°C (-130°F to -76°F). Do not store vials at -25°C to -15°C (-13°F to 5°F).
- e) Cartons of COMIRNATY single dose vials may be received at 2°C to 8°C (35°F to 46°F), and they should be stored at 2°C to 8°C (35°F to 46°F). Check that the carton has been previously updated to reflect the 10-week refrigerated expiry date.
- f) The total time out of refrigeration (at temperatures between 8°C and 25°C (46°F and 77°F)) must not exceed 12 hours.

4) Regardless of presentation, during storage, minimize exposure to room light, and avoid exposure to direct sunlight and ultraviolet light.

5) Regardless of storage condition, the vaccine should not be used after the expiration date printed on the vials, prefilled syringes, and cartons.

# EL RIO HEALTH

<b>STANDING ORDER DESCRIPTION:</b> Standing Order for the Administration of Pfizer-BioNTech/COMIRNATY COVID-19 Vaccine	<b>REFERENCE NUMBER:</b> NUR-024-SOP-SO-041-A
<b>PAGE:</b> 7 of 16	<b>EFFECTIVE DATE:</b>

Verify the vials (including labels) prior to preparation and administration to help avoid vaccine administration errors

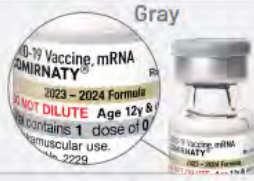
<b>Name</b>	COMIRNATY® (COVID-19 Vaccine, mRNA) 2023-2024 Formula Single Dose Vial <span style="background-color: white; color: #4F81BD; padding: 2px 5px; font-weight: bold;">DO NOT DILUTE</span>
<b>Age Group</b>	12 years and older
<b>Cap Color &amp; Label</b> <i>Cap colors and labels with matching borders</i>	Gray 
<b>Dose</b>	<b>30 mcg</b>
<b>Dose Volume</b>	0.3 mL
<b>Dilution</b>	<b>DO NOT DILUTE</b>
<b>Doses per Vial</b>	<b>Single Dose Vial<sup>a</sup></b>
<b>Storage Conditions</b>	
<b>Ultra-Low-Temperature (ULT) Freezer</b> [-90 °C to -60 °C (-130 °F to -76 °F)]	18 months <sup>b</sup>
<b>Freezer [-25 °C to -15 °C (-13 °F to 5 °F)]</b>	<b>DO NOT STORE</b>
<b>Refrigerator [2 °C to 8 °C (35 °F to 46 °F)]</b>	Up to 10 weeks <sup>c</sup>
<b>Room Temperature [8 °C to 25 °C (46 °F to 77 °F)]</b>	A total of 12 hours
<b>After Puncture [2 °C to 25 °C (35 °F to 77 °F)]</b>	N/A

<sup>a</sup>Low dead-volume syringes and/or needles are not required for single dose vial (SDV).

<sup>b</sup>If cartons are received refrigerated at 2 °C to 8 °C (35 °F to 46 °F), they should be stored in a refrigerator at 2 °C to 8 °C (35 °F to 46 °F). Regardless of storage condition, the vaccine should not be used after the expiration date printed on the vials and cartons.

<sup>c</sup>The 10-week refrigerated expiry date should be recorded on the carton at the time of transfer to 2 °C to 8 °C (35 °F to 46 °F). Check to ensure that cartons of COMIRNATY single dose vials received at 2 °C to 8 °C (35 °F to 46 °F) have been previously updated to reflect the 10-week refrigerated expiry date.

# EL RIO HEALTH

<b>STANDING ORDER DESCRIPTION:</b> Standing Order for the Administration of Pfizer-BioNTech/COMIRNATY COVID-19 Vaccine	<b>REFERENCE NUMBER:</b> NUR-024-SOP-SO-041-A
<b>PAGE:</b> 8 of 16	<b>EFFECTIVE DATE:</b>

Verify the prefilled syringes (including labels) prior to preparation and administration to help avoid vaccine administration errors

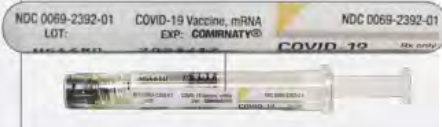
	COMIRNATY® (COVID-19 Vaccine, mRNA) 2023-2024 Formula GLASS SINGLE DOSE PREFILLED SYRINGE <sup>a</sup>	COMIRNATY® (COVID-19 Vaccine, mRNA) 2023-2024 Formula PLASTIC SINGLE DOSE PREFILLED SYRINGE <sup>a</sup>
<b>Name</b>		
<b>Age Group</b>	12 years and older	12 years and older
<b>Verify syringe label states "2023-2024 Formula"</b>		
<b>Confirm NDC</b>		
<b>Dose</b>	<b>30 mcg</b>	<b>30 mcg</b>
<b>Dose Volume</b>	0.3 mL	0.3 mL
<b>Dilution</b>	N/A	N/A
<b>Doses per Syringe</b>	Single Dose Prefilled Syringe <sup>a</sup>	Single Dose Prefilled Syringe <sup>b</sup>
	<b>Storage Conditions<sup>c</sup></b>	<b>Storage Conditions<sup>c</sup></b>
<b>Ultra-Low-Temperature (ULT) Freezer [-90 °C to -60 °C (-130 °F to -76 °F)]</b>	<b>DO NOT STORE</b>	9 months <sup>b</sup>
<b>Freezer [-25 °C to -15 °C (-13 °F to 5 °F)]</b>	<b>DO NOT STORE</b>	<b>DO NOT STORE</b>
<b>Refrigerator [2 °C to 8 °C (35 °F to 46 °F)]</b>	Refrigerator-stable for up to 6 months from date of manufacture to the expiration date printed on the carton and on the syringe labels.	Check to ensure that cartons of COMIRNATY plastic prefilled syringes received at 2 °C to 8 °C (35 °F to 46 °F) have been previously updated to reflect the 10-week refrigerated expiry date.
<b>Room Temperature [8 °C to 25 °C (46 °F to 77 °F)]</b>	Must not exceed 12 hours <sup>d</sup>	Must be used within 4 hours of thawing <sup>d</sup>

<sup>a</sup>Prefilled syringes for individuals 12 years of age and older are available in limited quantities.

<sup>b</sup>If cartons are received refrigerated at 2 °C to 8 °C (35 °F to 46 °F), they should be stored in a refrigerator at 2 °C to 8 °C (35 °F to 46 °F). Regardless of storage condition, the vaccine should not be used after the expiration date printed on the prefilled syringes and cartons.

<sup>c</sup>Regardless of presentation, during storage, minimize exposure to room light, and avoid exposure to direct sunlight and ultraviolet light.

<sup>d</sup>After removing the tip cap and attaching an appropriate needle, the prefilled syringe should be used immediately. If it cannot be used immediately, it must be used within 4 hours.

## f. Preparation Instructions

- 1) The COMIRNATY COVID-19 Vaccine is administered intramuscularly
- 2) Choose the correct equipment, including the correct needle size.
- 3) **Withdrawing vaccine from a vial:**
  - a) Cleanse the stopper on the vial with sterile alcohol prep pad.
  - a) Withdraw 0.3 mL vaccine into the syringe. Ensure the prepared syringe is not cold to the touch.
  - b) Remove any significant air bubbles with the needle still in the vial to avoid loss of vaccine. Use the same needle to withdraw and administer the vaccine, unless contaminated or damaged.

# EL RIO HEALTH

<b>STANDING ORDER DESCRIPTION:</b> Standing Order for the Administration of Pfizer-BioNTech/COMIRNATY COVID-19 Vaccine	<b>REFERENCE NUMBER:</b> NUR-024-SOP-SO-041-A
<b>PAGE:</b> 9 of 16	<b>EFFECTIVE DATE:</b>

## 5. Dosage Forms and Strengths:

- a. COMIRNATY is a suspension for injection.
- b. A single dose is 0.3 mL.

## 6. Vaccine Administration

- a. Administer the vaccine as per the *Administration of Medication – Intramuscular Injection* Nursing policy [NUR-011-SOP-MA-005](#)
- b. Visually inspect for particulate matter and discoloration prior to administration, whenever solution and container permit. The vaccine will be a white to off-white suspension. Do not administer if vaccine is discolored or contains particulate matter.
- c. Administer the 0.3 mL dose intramuscularly immediately after preparation. For the prefilled syringe, administer the entire volume to deliver a single 0.3 mL dose.

## 7. Vaccination Schedule

- a. COMIRNATY is administered as a single dose for individuals 12 years of age and older.
- b. For individuals previously vaccinated with any COVID-19 vaccine, administer the dose of COMIRNATY at least 2 months after the last dose of COVID-19 vaccine.

## 8. Individuals 12 Years of Age and Older with Certain Kinds of Immunocompromise see Table 1

- a. People who have received at least 3 mRNA COVID-19 vaccine doses, including 1 dose of updated (2023–2024 Formula) mRNA vaccine, may receive 1 or more additional updated (2023–2024 Formula) mRNA vaccine doses:
  - 1) For those ages 12 years and older, a dose from either manufacturer may be administered.
- b. People ages 12 years and older who previously received Novavax COVID-19 Vaccine or Janssen COVID-19 Vaccine, including those who received any mRNA vaccine dose(s), are recommended to receive 1 dose of updated (2023–2024 Formula) mRNA vaccine from either manufacturer.
  - 1) These people may receive 1 or more additional updated (2023–2024 Formula) mRNA vaccine doses from either manufacturer.

**CDC Recommended COVID-19 vaccination schedule for people who are moderately or severely immunocompromised by COVID-19 vaccination history, ~~September 15, 2023~~ **October 25, 2023****

**Table 1**

# EL RIO HEALTH

<b>STANDING ORDER DESCRIPTION:</b> Standing Order for the Administration of Pfizer-BioNTech/COMIRNATY COVID-19 Vaccine	<b>REFERENCE NUMBER:</b> NUR-024-SOP-SO-041-A
<b>PAGE:</b> 10 of 16	<b>EFFECTIVE DATE:</b>

COVID-19 vaccination history prior to updated (2023–2024 Formula) vaccine¹	Updated (2023–2024 Formula) vaccine	Number of updated (2023–2024 Formula) doses indicated*	Dosage (mL/ug)	Vaccine vial cap and label colors⁵	Interval between doses
Unvaccinated	Moderna	3	0.5 mL/50 ug	Dark blue cap; blue label	Dose 1 and Dose 2: 4 weeks Dose 2 and Dose 3: At least 4 weeks
	OR				
	Novavax	2	0.5 mL/5 ug rS protein and 50 ug Matrix-M adjuvant	Blue cap; blue label	Dose 1 and Dose 2: 3 weeks
	OR				
1 dose any Moderna	Pfizer-BioNTech	3	0.3 mL/30 ug	Gray cap; gray label	Dose 1 and Dose 2: 3 weeks Dose 2 and Dose 3: At least 4 weeks
	OR				
2 doses any Moderna	Moderna	2	0.5 mL/50 ug	Dark blue cap; blue label	Dose 1: 4 weeks after last dose Dose 1 and Dose 2: At least 4 weeks
1 dose any Pfizer-BioNTech	Moderna	1	0.5 mL/50 ug	Dark blue cap; blue label	At least 4 weeks after last dose
2 doses any Moderna	Pfizer-BioNTech	2	0.3 mL/30 ug	Gray cap; gray label	Dose 1: 3 weeks after last dose Dose 1 and Dose 2: At least 4 weeks
1 dose any Pfizer-BioNTech	Pfizer-BioNTech	1	0.3 mL/30 ug	Gray cap; gray label	At least 4 weeks after last dose
2 doses any Pfizer-BioNTech	Moderna	1	0.5 mL/50 ug	Dark blue cap; blue label	At least 8 weeks after last dose
3 or more doses any mRNA vaccine	OR				
	Novavax	1	0.5 mL/5 ug rS protein and 50 ug Matrix-M adjuvant	Blue cap; blue label	At least 8 weeks after last dose
	OR				
	Pfizer-BioNTech	1	0.3 mL/30 ug	Gray cap; gray label	At least 8 weeks after last dose
1 or more doses Novavax or Janssen, including in combination with any Original monovalent or bivalent COVID-19 vaccine doses	Moderna	1	0.5 mL/50 ug	Dark blue cap; blue label	At least 8 weeks after last dose
	OR				
	Novavax	1	0.5 mL/5 ug rS protein and 50 ug Matrix-M adjuvant	Blue cap; blue label	At least 8 weeks after last dose
	OR				
1 or more doses Novavax or Janssen, including in combination with any Original monovalent or bivalent COVID-19 vaccine doses	Pfizer-BioNTech	1	0.3 mL/30 ug	Gray cap; gray label	At least 8 weeks after last dose
	OR				

# EL RIO HEALTH

<b>STANDING ORDER DESCRIPTION:</b> Standing Order for the Administration of Pfizer-BioNTech/COMIRNATY COVID-19 Vaccine	<b>REFERENCE NUMBER:</b> NUR-024-SOP-SO-041-A
<b>PAGE:</b> 11 of 16	<b>EFFECTIVE DATE:</b>

**Abbreviation:** rS = recombinant spike

\*For children who transition from age 11 years to age 12 years during the initial vaccination series:

- **Moderna series:** Children are recommended to receive updated (2023–2024 Formula) Moderna COVID-19 Vaccine, 0.5 mL/50ug (dark blue cap; blue label) for all doses received on or after turning age 12 years. Alternatively, they may complete the 3-dose series with updated (2023–2024 Formula) Moderna COVID-19 Vaccine for children ages 5–11 years, 0.25 mL/25ug (dark blue cap; green label), as per the [FDA EUA](#)
- **Pfizer-BioNTech series:** Children are recommended to receive updated (2023–2024 Formula) Pfizer-BioNTech COVID-19 Vaccine, 0.3 mL/30 ug (gray cap; gray label) for all doses received on or after turning age 12 years. Alternatively, they may complete the 3-dose series with updated (2023–2024 Formula) Pfizer-BioNTech COVID-19 Vaccine for children ages 5–11 years, 0.3 mL/10 ug (blue cap; blue label), as per the [FDA EUA](#) .

†COVID-19 vaccination history refers to previous receipt of doses of Original monovalent mRNA or bivalent mRNA vaccine or a combination of the two; for people ages 12 years and older, Original monovalent Novavax COVID-19 Vaccine doses, alone or in combination with any mRNA vaccine doses; and for people ages 18 years and older, Janssen COVID-19 Vaccine doses, alone or in combination with any mRNA or Original monovalent Novavax vaccine doses.

‡Apart from the administration of additional doses, the [FDA EUA for Novavax COVID-19 Vaccine](#) does not provide for a specific vaccination schedule for people who are moderately or severely immunocompromised. People ages 12 years and older who are moderately or severely immunocompromised have the option to receive 1 additional dose of updated (2023–2024 Formula) Moderna COVID-19 Vaccine, 0.5 mL/50 ug (dark blue cap; blue label) updated (2023–2024 Formula) Novavax COVID-19 Vaccine; or updated (2023–2024 Formula) Pfizer-BioNTech COVID-19 Vaccine, 0.3 mL/30 ug (gray cap; gray label) a least 2 months following the last recommended updated (2023–2024 Formula) vaccine dose. Further additional doses may be administered, informed by the clinical judgement of a healthcare provider and personal preference and circumstances. Any further additional doses should be administered at least 2 months after the last updated (2023–2024 Formula) COVID-19 vaccine dose.

§Updated (2023–2024 Formula) Moderna COVID-19 Vaccine and updated (2023–2024 Formula) Pfizer-BioNTech COVID-19 Vaccine are also available in a prefilled, single-dose syringe for people ages 12 years and older.

**NOTE:**

**Classification for Moderate and Severe Immunocompromised Patient:**

- Active treatment for solid tumor and hematologic malignancies
- Hematologic malignancies associated with poor responses to COVID-19 vaccines regardless of current treatment status (e.g., chronic lymphocytic leukemia, non-Hodgkin lymphoma, multiple myeloma, acute leukemia)
- Receipt of solid-organ transplant and taking immunosuppressive therapy
- Receipt of CAR-T-cell or hematopoietic stem cell transplant (within 2 years of transplantation or taking immunosuppression therapy)
- Moderate or severe primary immunodeficiency (e.g., common variable immunodeficiency disease, severe combined immunodeficiency, DiGeorge syndrome, Wiskott-Aldrich syndrome)
- Advanced HIV infection (people with HIV and CD4 cell counts less than 200/mm<sup>3</sup>, history of an AIDS-defining illness without immune reconstitution, or clinical manifestations of symptomatic HIV) or untreated HIV infection
- Active treatment with high-dose corticosteroids (i.e., ≥20mg prednisone or equivalent per day), alkylating agents, antimetabolites, transplant-related immunosuppressive drugs, cancer chemotherapeutic agents classified as severely immunosuppressive, tumor-necrosis (TNF) blockers, and other biologic agents that are immunosuppressive or immunomodulatory.

# EL RIO HEALTH

<b>STANDING ORDER DESCRIPTION:</b> Standing Order for the Administration of Pfizer-BioNTech/COMIRNATY COVID-19 Vaccine	<b>REFERENCE NUMBER:</b> NUR-024-SOP-SO-041-A
<b>PAGE:</b> 12 of 16	<b>EFFECTIVE DATE:</b>

## 9. Documentation

- a. Document each employee/patient's vaccine administration information and follow up in the following places:
  - 1) Electronic Health Record (EHR): Record the date the vaccine was administered, the manufacturer and lot number, the vaccination site and route, and the name and title of the person administering the vaccine. If vaccine was not given, record the reason(s) for non-receipt of the vaccine (e.g., medical contraindication, patient refusal).
  - 2) Informed consent
  - 3) Vaccination record card: Date of vaccination, product name/manufacturer, lot number, and name/location of the health center and staff administering vaccine. For individuals with certain kinds of immunocompromise, include the date when the recipient needs to return for the second dose of COMIRNATY (COVID-19 Vaccine, mRNA). Give to the vaccine recipient.
  - 4) Document Patient Package Insert for COMIRNATY (COVID-19 Vaccine, mRNA) (2023-2024 Formula Information for Recipients and Caregivers was given.

## 10. Preparation for Managing Medical Emergency:

- a. Appropriate medical treatment to manage immediate allergic reactions must be immediately available in the event an acute anaphylactic reaction occurs following administration of the COMIRNATY (COVID-19 Vaccine, mRNA).
- b. Monitor COMIRNATY (COVID-19 Vaccine, mRNA) recipients for the occurrence of immediate adverse reactions according to the Centers for Disease Control and Prevention guidelines (<https://www.cdc.gov/vaccines/covid-19/>).
- c. Observe patients after vaccination to monitor for the occurrence of immediate adverse reactions:
  - 1) All persons: 15 minutes
  - 2) Persons with a history of any anaphylaxis: monitor for an additional 15 minutes for total of 30 minutes.
- d. Be prepared to manage a medical emergency related to the administration of vaccine. Refer to [COP-051-SOP-MM-005 Medical Emergency Response Process and Listing of Contents of Emergency Bag](#)

## 11. Adverse Reaction Reporting

- a. Report any adverse effect or patient intolerance to medication to the provider and health center manager immediately. Adverse events/reactions/incidents will be entered into the electronic incident reporting system – **Healthicity/Compliance Manager**. All reports are to be entered by the end of the working day on which the event occurred. The link for the electronic reporting system is found on the El Rio Health SharePoint site under common links – **Incident Report/Healthicity**. Any supporting materials may be added as documents. The incident is

# EL RIO HEALTH

<b>STANDING ORDER DESCRIPTION:</b> Standing Order for the Administration of Pfizer-BioNTech/COMIRNATY COVID-19 Vaccine	<b>REFERENCE NUMBER:</b> NUR-024-SOP-SO-041-A
<b>PAGE:</b> 13 of 16	<b>EFFECTIVE DATE:</b>

received and reviewed by Risk Management and an investigator(s) assigned.

- b. Report all adverse reactions to the federal Vaccine Adverse Event Reporting System (VAERS) at <https://vaers.hhs.gov/reportevent.html>, or (800) 822-7967. VAERS report forms are available at <https://vaers.hhs.gov/reportevent.html>.

## 12. Training / Competencies

- a. All licensed nurses, medical assistants' pharmacists, and pharmacy interns will show knowledge proficiency of this standing order on an annual basis.
- b. Onboarding staff will complete competency prior to completion of their probation.
- c. Competencies will be completed in Lippincott Procedures or other platform approved by the organization.
- d. Health Center Managers, Associate Managers and Pharmacy Managers are responsible for ensuring their staff complete their competencies annually.

## REFERENCES:

2023 Pfizer Inc, COVID-19 Vaccines by BioNTech and Pfizer.

[COVID-19 vaccines by BioNTech and Pfizer \(cvdvaccine-us.com\)](https://www.cvdvaccine-us.com)

2023 Pfizer Inc. Information for Recipients and Caregivers Comirnaty COVID-19 vaccine mRNA 2023-2023 Formula) **Revised 10/2023**

[labeling.pfizer.com/ShowLabeling.aspx?id=16351&Section=PPI](https://labeling.pfizer.com/ShowLabeling.aspx?id=16351&Section=PPI)

U.S Food and Drug Administration. COMIRNATY COVID-19 Vaccine, mRNA. 9/26/23

[COMIRNATY | FDA](#)

Center for Disease Control and Prevention. Interim Clinical Considerations for Use of COVID-19 Vaccines in the United States. Last updated ~~September 15, 2023~~ **November 3, 2023.**

[https://www.cdc.gov/vaccines/covid-19/clinical-considerations/interim-considerations-us.html#:~:text=Updated%20\(2023%E2%80%932024%20Formula\)%20mRNA%20vaccines,-The%20number%20of&text=People%20ages%206%20months%20and,\)%20mRNA%20vaccine%20doses%2C%20respectively.](https://www.cdc.gov/vaccines/covid-19/clinical-considerations/interim-considerations-us.html#:~:text=Updated%20(2023%E2%80%932024%20Formula)%20mRNA%20vaccines,-The%20number%20of&text=People%20ages%206%20months%20and,)%20mRNA%20vaccine%20doses%2C%20respectively.)

# EL RIO HEALTH

<b>STANDING ORDER DESCRIPTION:</b> Standing Order for the Administration of Pfizer-BioNTech/COMIRNATY COVID-19 Vaccine	<b>REFERENCE NUMBER:</b> NUR-024-SOP-SO-041-A
<b>PAGE:</b> 14 of 16	<b>EFFECTIVE DATE:</b>

## Attachment A

### INFORMATION FOR RECIPIENTS AND CAREGIVERS

#### COMIRNATY (Cuh-mir'-na-tee) (COVID-19 VACCINE, mRNA) (2023-2024 Formula)

This summary is not intended to take the place of talking with your healthcare provider. If you have questions or would like more information, please talk with your healthcare provider.

#### What is COMIRNATY?

COMIRNATY is a vaccine for use in people 12 years of age and older to protect against COVID-19.

COMIRNATY may not protect all people who receive the vaccine.

COMIRNATY does not contain SARS-CoV-2, the virus that causes COVID-19. COMIRNATY cannot give you COVID-19.

#### Who should not get COMIRNATY?

You should not get COMIRNATY if you had:

- a severe allergic reaction after a previous dose of COMIRNATY or any Pfizer-BioNTech COVID-19 vaccine<sup>1</sup>
- a severe allergic reaction to any ingredient in these vaccines (see **What are the ingredients in COMIRNATY?**).

#### Before getting COMIRNATY, tell your vaccination provider about all of your medical conditions, including if you:

- have any allergies
- had a severe allergic reaction after receiving a previous dose of any COVID-19 vaccine
- have had myocarditis (inflammation of the heart muscle) or pericarditis (inflammation of the lining outside the heart)
- have a fever
- have a bleeding disorder or are on a blood thinner
- are immunocompromised or are on a medicine that affects your immune system
- are pregnant or plan to become pregnant
- are breastfeeding
- have received another COVID-19 vaccine
- have ever fainted in association with an injection

#### How is COMIRNATY given?

COMIRNATY is given as an injection into the muscle.

<sup>1</sup> COMIRNATY (2023-2024 Formula) is made the same way as Pfizer-BioNTech COVID-19 Vaccine (Original monovalent) and Pfizer-BioNTech COVID-19 Vaccine, Bivalent, but it encodes the spike protein of SARS-CoV-2 Omicron variant lineage XBB.1.5 (Omicron XBB.1.5).

# EL RIO HEALTH

<b>STANDING ORDER DESCRIPTION:</b> Standing Order for the Administration of Pfizer-BioNTech/COMIRNATY COVID-19 Vaccine	<b>REFERENCE NUMBER:</b> NUR-024-SOP-SO-041-A
<b>PAGE:</b> 15 of 16	<b>EFFECTIVE DATE:</b>

## What are the possible risks of COMIRNATY?

There is a remote chance that COMIRNATY could cause a severe allergic reaction. A severe allergic reaction would usually occur within a few minutes to 1 hour after getting a dose. For this reason, your vaccination provider may ask you to stay at the place where you received your vaccine for monitoring after vaccination. Signs of a severe allergic reaction can include:

- Difficulty breathing
- Swelling of your face and throat
- A fast heartbeat
- A bad rash all over your body
- Dizziness and weakness

Myocarditis (inflammation of the heart muscle) and pericarditis (inflammation of the lining outside the heart) have occurred in some people who have received mRNA COVID-19 vaccines, including COMIRNATY and Pfizer-BioNTech COVID-19 vaccines. Myocarditis and pericarditis following COMIRNATY have occurred most commonly in adolescent males 12 through 17 years of age. In most of these individuals, symptoms began within a few days following vaccination. The chance of having this occur is very low. You should seek medical attention right away if you or your child have any of the following symptoms after receiving the vaccine, particularly during the 2 weeks after receiving a dose of the vaccine:

- Chest pain
- Shortness of breath
- Feelings of having a fast-beating, fluttering, or pounding heart

Side effects that have been reported with COMIRNATY or Pfizer-BioNTech COVID-19 vaccines include:

- Severe allergic reactions
- Non-severe allergic reactions such as rash, itching, hives, or swelling of the face
- Myocarditis (inflammation of the heart muscle)
- Pericarditis (inflammation of the lining outside the heart)
- Injection site reactions: pain, swelling, redness, arm pain
- General side effects: tiredness, headache, muscle pain, chills, joint pain, fever, nausea, feeling unwell, swollen lymph nodes (lymphadenopathy), decreased appetite, diarrhea, vomiting, dizziness
- Fainting in association with injection of the vaccine

These may not be all the possible side effects of COMIRNATY. Ask your healthcare provider about any side effects that concern you.

Report vaccine side effects to FDA/CDC Vaccine Adverse Event Reporting System (VAERS). The VAERS toll-free number is 1-800-822-7967 or report online to <https://vaers.hhs.gov/reportevent.html>.

In addition, you can report side effects to Pfizer Inc. at 1-800-438-1985 or [www.pfizersafetyreporting.com](http://www.pfizersafetyreporting.com).

## What if you are pregnant or breastfeeding?

If you are pregnant or breastfeeding, discuss your options with your healthcare provider.

# EL RIO HEALTH

<b>STANDING ORDER DESCRIPTION:</b> Standing Order for the Administration of Pfizer-BioNTech/COMIRNATY COVID-19 Vaccine	<b>REFERENCE NUMBER:</b> NUR-024-SOP-SO-041-A
<b>PAGE:</b> 16 of 16	<b>EFFECTIVE DATE:</b>

## What are the ingredients in COMIRNATY?

COMIRNATY contains the following ingredients:

- messenger ribonucleic acid (mRNA)
- lipids (((4-hydroxybutyl)azanediyl)bis(hexane-6, 1-diyl)bis(2-hexyldecanoate), 2 [(polyethylene glycol)-2000]-N,N-ditetradecylacetamide, 1,2-distearoyl-sn-glycero-3-phosphocholine, and cholesterol)
- tromethamine
- tromethamine hydrochloride
- sucrose

COMIRNATY does not contain preservatives.

This Information for Recipients and Caregivers may have been updated. For the most recent Information for Recipients and Caregivers, please visit <https://dailymed.nlm.nih.gov/dailymed/>.

If you have questions, talk to your healthcare provider or visit [www.COMIRNATY.com](http://www.COMIRNATY.com) or call 1-877-VAX-CO19 (1-877-829-2619).

**BIONTECH**

Manufactured for

BioNTech Manufacturing GmbH

An der Goldgrube 12

55131 Mainz, Germany



Manufactured by

Pfizer Inc., New York, NY 10001

LAB-1587-1.0

US Govt. License No. 2229

Revised: 09/2023

## EL RIO HEALTH

**SCOPE:**

This procedure applies to **CLINICAL** and **NON-CLINICAL** departments in the following El Rio Health functional areas and/or locations (check all that apply):

- |   |   |   |  |
|---|---|---|--|
| <input checked="" type="checkbox"/> Family Medicine   | <input checked="" type="checkbox"/> Same Day Appt. Clinic | <input type="checkbox"/> Radiology              | <input type="checkbox"/> MOR/DOS         |
| <input checked="" type="checkbox"/> Internal Medicine | <input checked="" type="checkbox"/> HOB/HOU               | <input type="checkbox"/> Pharmacy               | <input type="checkbox"/> Administration  |
| <input checked="" type="checkbox"/> Pediatrics        | <input checked="" type="checkbox"/> SIA                   | <input type="checkbox"/> Laboratory             | <input type="checkbox"/> Human Resources |
| <input checked="" type="checkbox"/> Dental            | <input type="checkbox"/> Care Coordination                | <input type="checkbox"/> HIM                    | <input type="checkbox"/> Accounting      |
| <input checked="" type="checkbox"/> Behavioral Health | <input type="checkbox"/> Wellness                         | <input type="checkbox"/> Information Technology | <input type="checkbox"/> Business Office |
| <input checked="" type="checkbox"/> Midwives          | <input checked="" type="checkbox"/> Clinical Pharmacy     | <input type="checkbox"/> Patient Communications | <input type="checkbox"/> Coding          |
| <input checked="" type="checkbox"/> OB/GYN            | <input type="checkbox"/> Facilities                       | <input type="checkbox"/> Advocacy & Eligibility | <input type="checkbox"/> Security        |
| <input type="checkbox"/> Referrals                    | <input type="checkbox"/> Purchasing                       | <input type="checkbox"/> Physical Therapy       | <input type="checkbox"/> Transportation  |

<p><b>PROCEDURE DESCRIPTION:</b> Nursing Care Process for Blood Pressure Nurse Visit and Hypertension Care Gap Outreach</p>	<p><b>PAGE:</b> 1 of 12</p>
<p><b>APPROVAL DATE:</b></p>	<p><b>REFERENCE NUMBER:</b> NUR-026-NCP-002</p>
<p><b>EFFECTIVE DATE:</b></p>	<p><b>DATES REVIEWED WITHOUT CHANGE:</b></p>
<p><b>NEXT REVIEW DATE:</b></p>	<p><b>REPLACES POLICY DATED:</b> Revised Retired Procedure-2018 NEW:11/2022</p>
<p><b>RESPONSIBILITY:</b> Regional Health Center Directors Medical Directors</p>	<p><b>DATE RETIRED:</b> N/A</p>
<p><b>APPROVALS:</b> PPC: CAC:</p>	

**PURPOSE:** To provide clinical staff with a procedure for Hypertension Care Gap outreach and a care process for conducting a Nurse Visit for Blood Pressure checks.

The care process will include but not limited to:

- Patient education / determine patient’s readiness to learn, barriers to learning and learning preferences
- Screening for changes in patient condition during nurse visit appointments
- Standardized method of taking a patient’s blood pressure
- Standardized delivery and documentation of blood pressure, signs and symptoms, and condition changes
- Support of medication compliance
- Monitoring overall compliance with management regimen
- Method for patient follow-up, recall and referral to patient support services
- Implementation of care process

# EL RIO HEALTH

<b>PROCEDURE DESCRIPTION:</b> Nursing Care Process for Blood Pressure Nurse Visit and Hypertension Care Gap Outreach	<b>REFERENCE NUMBER:</b> NUR-026-NCP-002
<b>PAGE:</b> 2 of 12	<b>EFFECTIVE DATE:</b>

## **DEFINITION:**

### **ADULTS:**

Average ranges for adults (18 and over) are as follows:

~~Normal blood pressure—Systolic <120 mmHg and diastolic <80 mmHg~~

~~Elevated blood pressure—Systolic 120 to 129 mmHg and diastolic <80 mmHg~~

Systolic less than 130 AND Diastolic less than 80 (i.e., <130/80)

### **HYPERTENSION:**

- **Stage 1** – Systolic 130 to 139 mmHg or diastolic 80 to 89 mmHg
- **Stage 2** – Systolic at least 140 mmHg or diastolic at least 90 mmHg
- **Hypertensive crisis:** Systolic over 180 and/or diastolic over 120 on a repeat check, requires triage evaluation with patients needing prompt changes in medication if there are no other indications of problems, or immediate hospitalization if there are signs of organ damage.

### **METHODS:**

- **Manual Method:** This method is performed on children ages 3-12 years and older adults.
- **Electronic Method:** This method is performed on adults and children ages 13 years and up unless directed by a provider.
- **For detailed information on how to take a Blood Pressure,** please refer to [COP-050-SOP-VS-004 Measuring Blood Pressure REV4-2021.docx](#).
- See ATTACHMENT A for 7 tips on getting accurate BP reading,

**Clinical alert:** Do not measure blood pressure in an extremity with deep vein thrombosis, grafts, ischemic changes, incisions, trauma, arteriovenous fistula, hemodialysis shunt, or an extremity affected by lymphedema after a mastectomy or lumpectomy. Do not apply a blood pressure cuff over a Peripherally inserted central catheter (PICC) line or a midline catheter.

## **PROCEDURE:**

### A. **HYPERTENSION NURSE VISIT:**

1. Verify Patient with 2 patient identifiers (name and date of birth)
2. PRIOR to taking Blood Pressure (BP) → verify allergies, reconcile & refill medications per protocol, and check for signs and symptoms of Hypo/Hypertension
  - a. In the patient’s electronic health record, type “.BPCHECK” into the Notes Side Report. This will bring up a Nurse Blood Pressure Check SmartText to use for documentation.
  - b. Use ROS smart block to document any positive symptoms which might include chest pain, shortness of breath, headache, dizziness, or nausea. If any of these are positive, involve nurse triage process.
3. Have the patient sit and rest for **5 minutes**, allowing the patient to take a few moments *to breathe*

# EL RIO HEALTH

<b>PROCEDURE DESCRIPTION:</b> Nursing Care Process for Blood Pressure Nurse Visit and Hypertension Care Gap Outreach	<b>REFERENCE NUMBER:</b> NUR-026-NCP-002
<b>PAGE:</b> 3 of 12	<b>EFFECTIVE DATE:</b>

*deeply and relax, without speaking.* After the 5-minute rest period, take the patients vitals and follow the workflow, respectively.

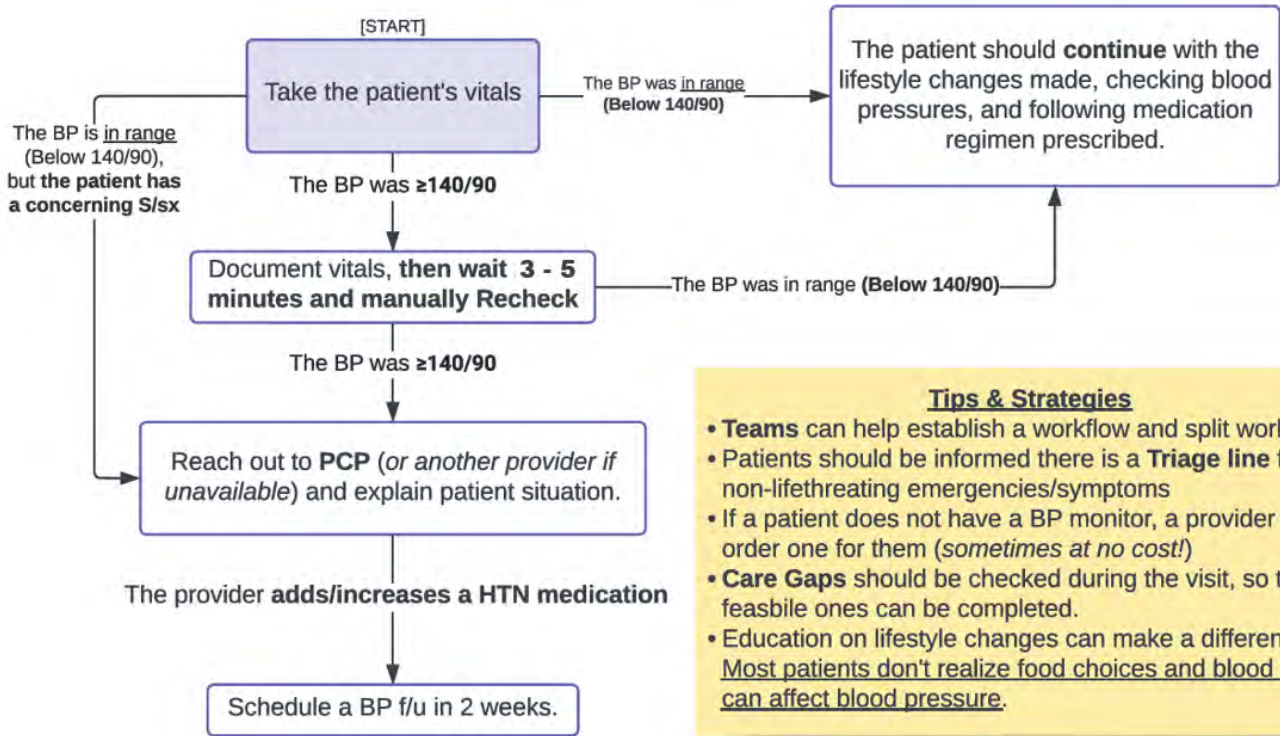

4. Complete documentation in the Notes Section, have the provider “**Cosign**” your note for any orders or instructions to provide patient prior release of visit. Refer to screen shot below.

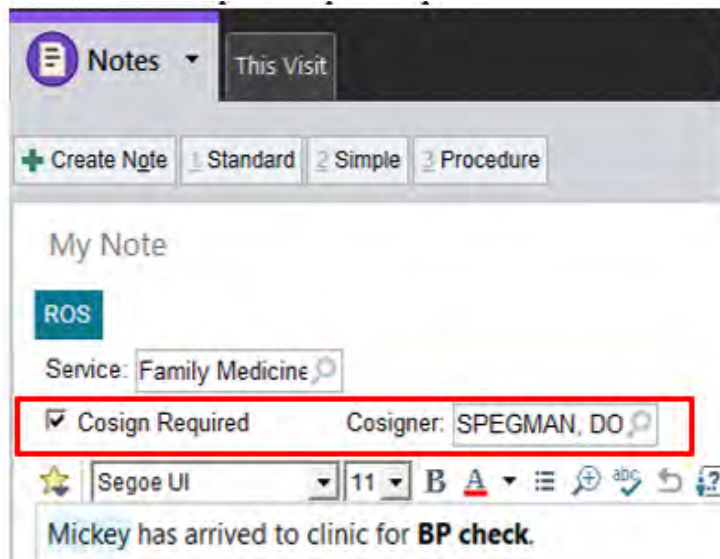

# EL RIO HEALTH

<b>PROCEDURE DESCRIPTION:</b> Nursing Care Process for Blood Pressure Nurse Visit and Hypertension Care Gap Outreach	<b>REFERENCE NUMBER:</b> NUR-026-NCP-002
<b>PAGE:</b> 4 of 12	<b>EFFECTIVE DATE:</b>

5. If needed, hand patient **ATTACHMENT B** regarding information on how to improve their Blood Pressure

## **B. CREATING HYPERTENSION CARE GAP REPORT:**

By providing patients with a BP check visit, we can help close care gaps. The following includes instructions on how to pull a provider's Hypertension (HTN) care gap list needed for outreach.

1. In **Electronic Health Record (EHR)**, go to upper left-hand corner and click on the bar graph icon.

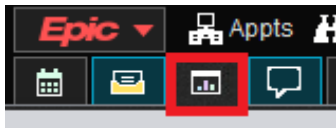

2. The title should have a drop-down arrow; **search** or **select El Rio My Panel Metrics** to open the dashboard

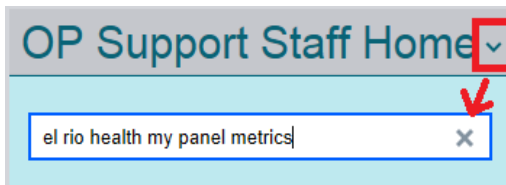

3. Summary level can be chosen by department, provider, location, etc. Choose the **“Provider-REGISTRY”** option and search for the provider you are looking to make the report for.



4. On the right side of the report, there is a **Hypertension section**. Left click on the percentage under the “MTD” column, and there should be the option to select “Patient Summary.”

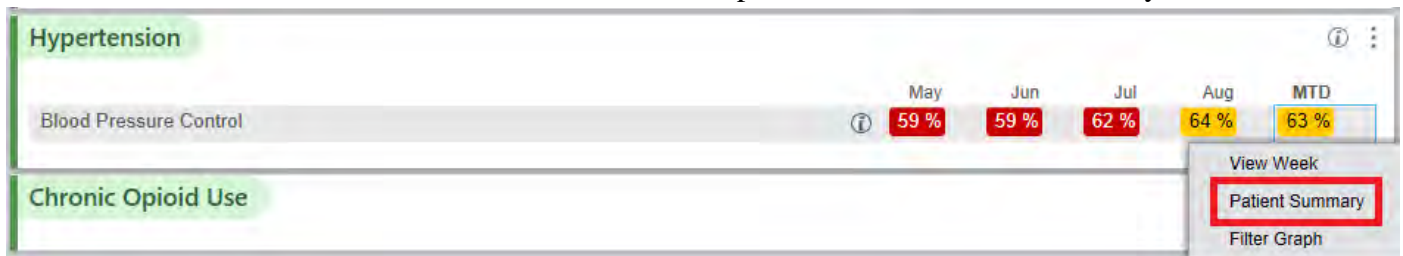

5. *Do not exit out of EHR, at this time a report will be running*

6. Once the report appears, click on the **FILTER** button, search for the “Outcome” option and select **“Outcome Not Met.”**

# EL RIO HEALTH

<b>PROCEDURE DESCRIPTION:</b> Nursing Care Process for Blood Pressure Nurse Visit and Hypertension Care Gap Outreach	<b>REFERENCE NUMBER:</b> NUR-026-NCP-002
<b>PAGE:</b> 5 of 12	<b>EFFECTIVE DATE:</b>

- After clicking **accept**, the updated list will reflect the patients needing a BP visit.
- a. **To send the list to the team**, click on Select All (upper right-hand corner).  
 Then select **Communication** and choose: Send Staff Message (see next image)

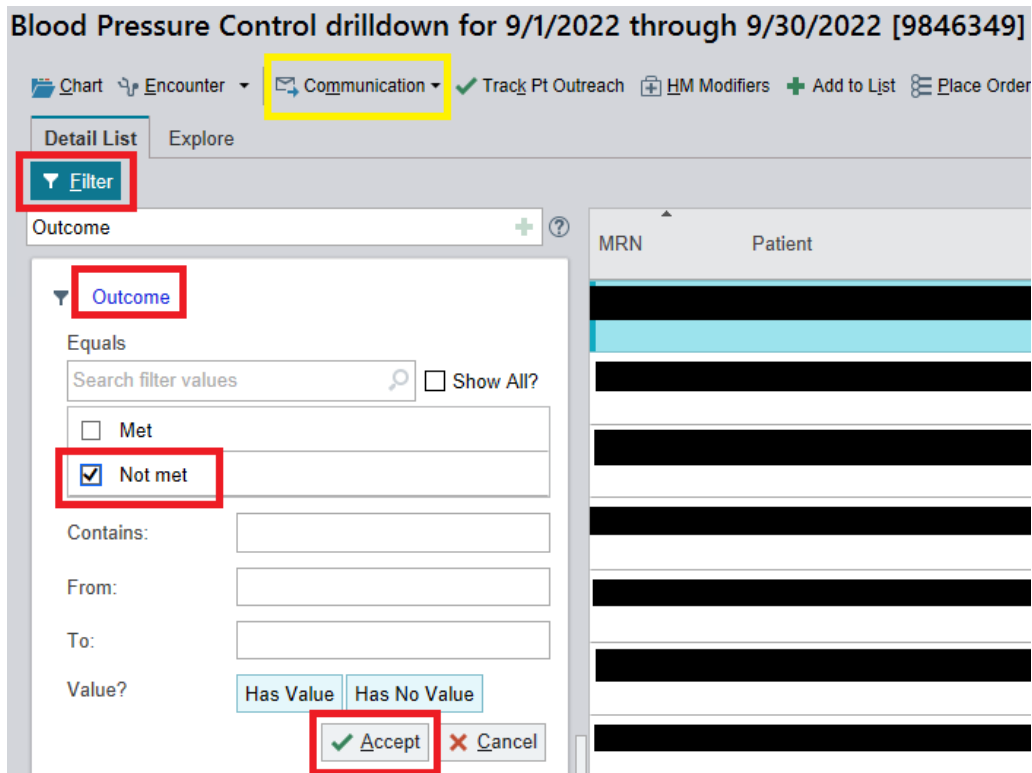

7. A screen will appear titled “Messages to Staff”: Insert the following in the appropriate areas.

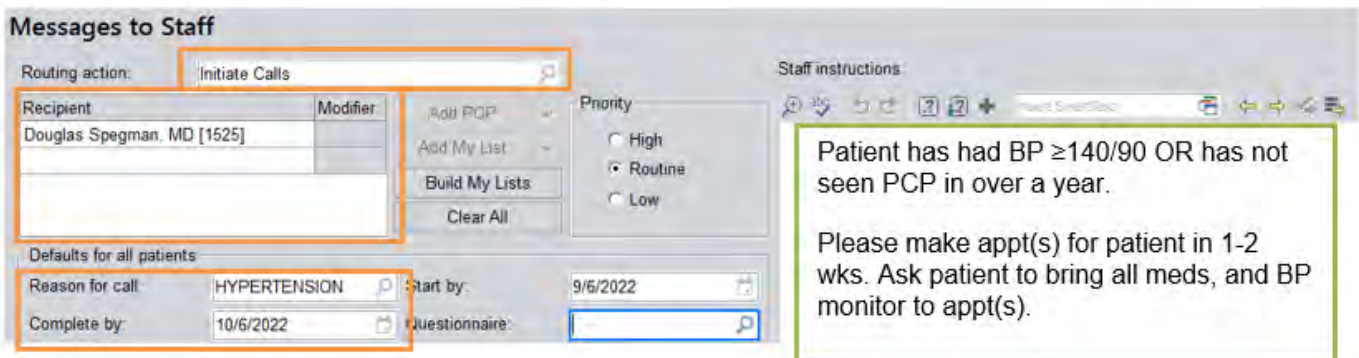

- a. **Routing Action:** “Initiate Calls”
- b. **Recipients:** Add appropriate pool, such as the provider’s team, or individual- **DO NOT** add multiple individuals as this duplicate the request.
- c. **Reason for call:** “Hypertension”
- d. **Complete by:** *Type “m+1”* to allow the staff 1 month to complete.

# EL RIO HEALTH

<b>PROCEDURE DESCRIPTION:</b> Nursing Care Process for Blood Pressure Nurse Visit and Hypertension Care Gap Outreach	<b>REFERENCE NUMBER:</b> NUR-026-NCP-002
<b>PAGE:</b> 6 of 12	<b>EFFECTIVE DATE:</b>

e. **Staff Instructions:** the reason for the message

## C. SCHEDULING VISITS:

1. If it has been **6 months or more**, schedule the patient with their **Primary Care Provider (PCP) within 1-2 weeks**.
  - a. If an appointment with the PCP is unavailable, **schedule a nurse visit**.
  - b. **Remind the patient** that they should bring **ALL** their medications, Blood Pressure Monitor, and available BP readings to either visit.
2. If the patient has **poor lifestyle habits** and/or **comorbidities** (Chronic Kidney Disease, Congestive Heart Failure, Diabetes Mellitus II), also schedule them an appointment with a **Dietician and/or Pharm D**.

## D. PATIENT OUTREACH:

1. Messages regarding outreach can be found in the **InBasket** within the **Initiate Call** folder.
2. Choose a patient and select **Initiate Call**.

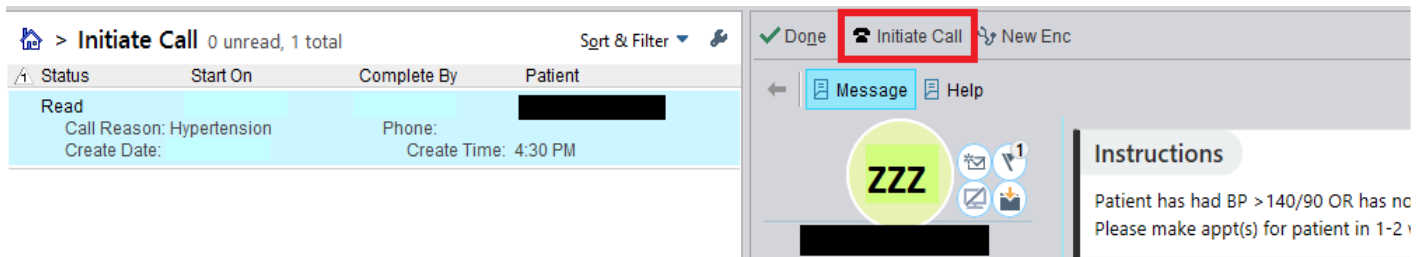

3. Document the following items as show in the image below:
  - a. **Contacted via:** Method of Contact (Phone, In person, etc.)
  - b. **Contacted about:** "Hypertension"
  - c. **Next Contact:** Date for staff to follow up if applicable.

# EL RIO HEALTH

<b>PROCEDURE DESCRIPTION:</b> Nursing Care Process for Blood Pressure Nurse Visit and Hypertension Care Gap Outreach	<b>REFERENCE NUMBER:</b> NUR-026-NCP-002
<b>PAGE:</b> 7 of 12	<b>EFFECTIVE DATE:</b>

**Track Pt Outreach**

Contacted via  
Telephone In Person Mail Telephone

Contacted about  
+ Add ✓ Hypertension

Next contact  
10/6/2022 1 Week 1 Month 3 Months 6 Months

4. In the **Notes Section**, you should document:
- a. if you called the patient and left a voicemail
  - b. if you were able to reach the patient and scheduled appointments for them
  - c. if it were your third attempt and you would be sending a letter

# EL RIO HEALTH

<b>PROCEDURE DESCRIPTION:</b> Nursing Care Process for Blood Pressure Nurse Visit and Hypertension Care Gap Outreach	<b>REFERENCE NUMBER:</b> NUR-026-NCP-002
<b>PAGE:</b> 8 of 12	<b>EFFECTIVE DATE:</b>

## ATTACHMENT A

**TARGET:BP™** | **AMA**

### 7 SIMPLE TIPS TO GET AN ACCURATE BLOOD PRESSURE READING

The common positioning errors can result in inaccurate blood pressure measurement. Figures shown are estimates of how improper positioning can potentially impact blood pressure readings.

Sources:

1. *Pickering, et al. Recommendations for Blood Pressure Measurement in Humans and Experimental Animals Part 1: Blood Pressure Measurement in Humans. Circulation. 2005;111: 697-716.*
2. *Handler J. The importance of accurate blood pressure measurement. The Permanente Journal/Summer 2009/Volume 13 No. 3 51*

This 7 simple tips to get an accurate blood pressure reading was adapted with permission of the American Medical Association and The Johns Hopkins University. The original copyrighted content can be found at [www.ama-assn.org/ama-johns-hopkins-blood-pressure-resources](http://www.ama-assn.org/ama-johns-hopkins-blood-pressure-resources).

Content provided by **MAPBP™**

This resource is part of AMA MAP BP™, a quality improvement program. Using a single or subset of AMA MAP BP tools or resources does not constitute implementing this program. AMA MAP BP includes guidance from AMA hypertension experts and has been shown to improve BP control rates by 10 percentage points and sustain results.

©2020 American Medical Association. All Rights Reserved. 10/20 MRG15940-IB

# EL RIO HEALTH

## PROCEDURE DESCRIPTION:

Nursing Care Process for Blood Pressure Nurse Visit and Hypertension Care Gap Outreach

## REFERENCE NUMBER:

NUR-026-NCP-002

PAGE: 9 of 12

## EFFECTIVE DATE:

**TARGET:BP™** |

### 7 CONSEJOS SIMPLES PARA OBTENER UNA LECTURA DE LA PRESIÓN ARTERIAL PRECISA

Los errores frecuentes de la posición pueden causar una medición de la presión arterial inexacta. Las cifras que se muestran son estimaciones de cómo una posición inadecuada puede afectar la lectura de la presión arterial.

Sources:  
1. Pickering, et al. Recommendations for Blood Pressure Measurement in Humans and Experimental Animals Part I: Blood Pressure Measurement in Humans. *Circulation*. 2005;111: 697-716.  
2. Handler J. The importance of accurate blood pressure measurement. *The Permanente Journal*/Summer 2009/Volume 13 No. 3 51.

Estos 7 consejos simples para obtener una lectura de la presión fueron adaptados con permiso de la American Medical Association y The Johns Hopkins University. El contenido original protegido por derechos de autor puede consultarse en [www.ama-assn.org/ama-johns-hopkins-blood-pressure-resources](http://www.ama-assn.org/ama-johns-hopkins-blood-pressure-resources).

Contenido proporcionado por  
**AMA** | **MAPBP™**

©2020 American Medical Association. Todos los derechos reservados.  
10/20 MRGI5940-1D

# EL RIO HEALTH

**PROCEDURE DESCRIPTION:**

Nursing Care Process for Blood Pressure Nurse Visit and Hypertension Care Gap Outreach

**REFERENCE NUMBER:**





NUR-026-NCP-002

**PAGE:** 10 of 12

**EFFECTIVE DATE:**

**ATTACHMENT B**

## What Can I Do To Improve My Blood Pressure?

Modification	Recommendation	Approximate SBP Reduction Range
 Weight reduction	Maintain normal body weight (BMI=18.5-24.9 kg/m <sup>2</sup> )	5 mm Hg
 DASH eating plan	Diet rich in fruits, vegetables, low fat dairy and reduced in fat	11 mm Hg
 Restrict sodium intake	<1500 mg of sodium per day	5-6 mm Hg
 Physical activity	Be more physically active. Aim for at least 90 to 150 minutes of aerobic exercise per week.	5-8 mm Hg
 Moderation of alcohol consumption	No more than 2 drinks/day for men and 1 drink/day for women	4 mm Hg

# EL RIO HEALTH

**PROCEDURE DESCRIPTION:**

Nursing Care Process for Blood Pressure Nurse Visit and Hypertension Care Gap Outreach



**REFERENCE NUMBER:**

NUR-026-NCP-002

**PAGE:** 11 of 12

**EFFECTIVE DATE:**

## ¿Qué puedo hacer para mejorar mi presión arterial?

Modificación	Recomendación	Valores de PAS aproximados Intervalo de reducción
 Reducción de peso	Mantenimiento de un peso corporal normal (IMC = 18,5 - 24,9 kg/m2)	5 mm Hg
 Dieta D.A.S.H.	Dieta rica en frutas y verduras, productos lácteos con bajo contenido de grasa	11 mm Hg
 Restricción en el consumo de sodio	<1500 mg de sodio diarios	5 - 6 mm Hg
 Actividad física	Aumente su actividad física. Tenga como objetivo realizar al menos entre 90 y 150 minutos de ejercicio aeróbico a la semana.	5 - 8 mm Hg
 Moderación del consumo de alcohol	No más de 2 copas/día para hombres y 1 copa/día para mujeres	4 mm Hg

PA = presión arterial, IMC = índice de masa corporal, PAS = presión arterial sistólica, DASH = Dietary Approaches to Stop Hypertension (enfoques dietéticos para detener la hipertensión)



Intervalos de acuerdo con las guías de práctica clínica para la hipertensión de 2017  
Recomendaciones para el tratamiento y control de la hipertensión

**REFERENCES:**

2022 Wolters Kluwer Health, Inc., Lippincott Procedures: Blood Pressure Assessment, Ambulatory Care: February 17, 2022

[Lippincott procedure for Blood Pressure Assessment](#)

American Heart Association; High Blood Pressure. November 13, 2017:

[High Blood Pressure | American Heart Association](#)

American College of Cardiology/American Heart Association (ACC/AHA). 2017 Guideline for High Blood Pressure in Adults. May 07, 2018

<https://www.acc.org/latest-in-cardiology/ten-points-to-remember/2017/11/09/11/41/2017-guideline-for-high-blood-pressure-in-adults>

**EL RIO HEALTH**

<b>PROCEDURE DESCRIPTION:</b> Nursing Care Process for Blood Pressure Nurse Visit and Hypertension Care Gap Outreach	<b>REFERENCE NUMBER:</b> NUR-026-NCP-002
<b>PAGE:</b> 12 of 12	<b>EFFECTIVE DATE:</b>

# EL RIO HEALTH

**SCOPE:**

This procedure applies to **CLINICAL** and **NON-CLINICAL** departments in the following El Rio Health functional areas and/or locations (check all that apply):

- |  |  |  |  |
|--|--|--|--|
| <input type="checkbox"/> Family Medicine   | <input type="checkbox"/> Same Day Appt. Clinic | <input type="checkbox"/> Radiology                         | <input type="checkbox"/> MOR/DOS         |
| <input type="checkbox"/> Internal Medicine | <input type="checkbox"/> HOB/HOU               | <input type="checkbox"/> Pharmacy                          | <input type="checkbox"/> Administration  |
| <input type="checkbox"/> Pediatrics        | <input type="checkbox"/> SIA                   | <input type="checkbox"/> Laboratory                        | <input type="checkbox"/> Human Resources |
| <input type="checkbox"/> Dental            |  | <input type="checkbox"/> HIM                               | <input type="checkbox"/> Accounting      |
| <input type="checkbox"/> Behavioral Health | <input type="checkbox"/> Care Coordination     | <input type="checkbox"/> Information Technology            | <input type="checkbox"/> Business Office |
| <input type="checkbox"/> Midwives          | <input type="checkbox"/> Wellness              | <input checked="" type="checkbox"/> Patient Communications | <input type="checkbox"/> Coding          |
| <input checked="" type="checkbox"/> OB/GYN |  | <input type="checkbox"/> Advocacy & Eligibility            | <input type="checkbox"/> Security        |
| <input type="checkbox"/> Clinical Pharmacy |  | <input type="checkbox"/> Facilities/Materials              | <input type="checkbox"/> Transportation  |

**PROCEDURE DESCRIPTION:**  
OB/GYN Appointment Scheduling

**PAGE:**  
1 of 5

**REFERENCE NUMBER:**  
PCM-105-SOP-001

**APPROVAL DATE:**

**DATES REVIEWED WITHOUT CHANGE:**

**EFFECTIVE DATE:**

**REPLACES PROCEDURE DATED:**  
Replaces PCM-105 dated 04/2016:05/2019:04/2021

**NEXT REVIEW DATE:**

**DATE RETIRED:**  
N/A

**RESPONSIBILITY:**

~~Chief Executive Officer~~  
~~OB/GYN Health Center Manager~~  
Chief Clinical Officer (CCO)  
OB/GYN Medical Director  
Patient Communications (PC) Leadership

**APPROVALS:**

PPC:  
CAC:

**PURPOSE:** It is the purpose of El Rio Health to set forth procedures for the appropriate scheduling of appointments at El Rio Health OB/GYN (Obstetrics and Gynecology) by PC staff.

**DEFINITIONS:**

**New Patient:** A new patient is one who has **never been seen** by an El Rio Health OB/GYN provider.

**Established Patient:** An established patient is one who **has been seen** by an El Rio Health OB/GYN provider **within the last 3 years**.

**PROCEDURE:**

**I. General Appointment Principles:**

1. One reason per visit preferred.
2. When scheduling OB/GYN appointments, patient should be offered their OB/GYN provider of

# EL RIO HEALTH

<b>PROCEDURE DESCRIPTION:</b> OB/GYN Appointment Scheduling	<b>REFERENCE NUMBER:</b> PCM-105-SOP-001
<b>PAGE:</b> 2 of 5	<b>EFFECTIVE DATE:</b>

record first.

3. **If a sooner appointment is available with another provider within the group and If patient is requesting a sooner Preventative appointment NP Ramirez and CNM Johnson are an option for these types of appointments .**
4. **If an establish patient wishes to Transfer to another provider within the group -Document Request and schedule**
5. The only exception as to when the patient should see the same provider for their OB/GYN appointments is post-operative **care .**
6. If patient requires an interpreter, the appointment will required to be scheduled 2 weeks out. Once scheduled, a task is to be sent to the health center manager for interpreter services to be arranged.
7. **Urgent /Priority Request** -If there are there are no available appointments – Transfer call to OB/GYN office. **OB/GYN department will manage waitlist.**
8. If an El Rio Health OB/GYN patient delivers at a different hospital, patient must see the delivering provider for visit to be considered Post-partum
  - a. Patients can be offered a pelvic exam / birth control appointment

## II. Appointment Scheduling

### 1. PC Reps Can Schedule the Following Categories / Events:

#### a. Gyn (GYN) (peach):

1. Annual
2. Irregular menses
3. Pelvic Pain
4. Tubal consultation
5. **Surgery consultation (Do Not schedule with NP Ramirez/CNM Johnson)**
6. Ovarian Cysts
7. Birth Control (BC) consults:
  - a. For patient to begin any type of birth control, a consult is required.
  - b. IUD / Nexplanon - Placement cannot be guaranteed at the initial visit, and patient should be advised that she may have to come back.
8. IUD / Nexplanon Inserts
  - a. After BC consult completed (see appointment history)
9. IUD / Nexplanon Removals
  - a. No consult needed to schedule
10. Pre-conception

#### b. Gyn Follow Up (GYN F/U) (purple) appointments for patients seen for the same diagnosis within a 3-4-month timeframe (see appointment history):

1. Contraception Surveillance (family planning).
2. IUD / Nexplanon Follow-up's are routinely scheduled for any concerns (i.e., pain, discomfort, cannot feel the device, etc.)
3. *Test Results*
4. ~~*RX Reviews*~~
5. *Continued concerns with same diagnosis*
6. *Post-Partum*
  - a. Confirm delivery date, location (TMC), and type of delivery (vaginal);

# EL RIO HEALTH

<b>PROCEDURE DESCRIPTION:</b> OB/GYN Appointment Scheduling	<b>REFERENCE NUMBER:</b> PCM-105-SOP-001
<b>PAGE:</b> 3 of 5	<b>EFFECTIVE DATE:</b>

Add to appointment details

- b. Routine post-partums are scheduled within 6-9 weeks of delivery date
  - i. If 10 weeks or after, schedule next available GYN Pelvic Exam
- c. If patient is having any concerns or complications, always transfer patient to the office for evaluation .

7. *OB/GYN Wound checks*

**c. Telehealth 20 (brown)**

1. ~~See current telehealth workflow~~

d. **Obstetric Checks (OBC) (light teal):** Routine – for established OB patients

e. **Nurse Visit (yellow)** - for established OB patients

1. Depo Injections

- a. Confirm consent began with OB/GYN clinic

2. **Advanced Scheduling:** The following appointments are to only be scheduled / cancelled / rescheduled by OB/GYN clinic:

**( add ) Routine OB**

- a. New Obstetric Visits (NOB)
- b. OB BP Check
- c. OB Sick Visit
- d. OB Sono
- e. Post-Partum Cesarean Delivery
- f. Post-Operative (Post-Op)
- g. Catheter removals
- h. Colposcopies (COLPO)
- i. Endometrial Biopsies (ENDO BX)
- j. LEEP
- k. Lupron Injection
- l. NST
- m. Rocephin Injection
- n. Hospital Follow-Up/Miscarriage/ spontaneous abortion (SAB) Follow-Up
- o. Pre-Operative (Pre-op)
  1. Any calls regarding surgery (i.e., concerns, reschedules, or questions regarding date, time, or cost) should be tasked to the surgery coordinator

### III. Required Details for Appointments:

1. Indicate if patient is New or Established, the reason for visit, insurance name and identification number. Self-pay / sliding fee scale (SFS)
  - a. N. GYN (reason for visit), (insurance name ID#) / Self-Pay deposit \$300 / SFS (Copay amount)
  - b. E. GYN (reason for visit), (insurance name ID#) / Self-Pay deposit \$100 / SFS (Copay amount)
  - c. Exceptions:
    1. ~~OBC—Estimated Date of Delivery (EDD date)~~
    2. Routine Post-Partum: PP – delivered (date), TMC
    3. GYN F/U (reason for visit)
2. Advise patient of the correct arrival times and location.

# EL RIO HEALTH

<b>PROCEDURE DESCRIPTION:</b> OB/GYN Appointment Scheduling	<b>REFERENCE NUMBER:</b> PCM-105-SOP-001
<b>PAGE:</b> 4 of 5	<b>EFFECTIVE DATE:</b>

- a. New patients - 30mins early
- b. Established patients - 15mins early
  - 1. ~~Except ROB – arrive on time~~

## IV. Urgent Requests for Appointments:

1. If there is a need for an **urgent** appointment request, transfer the call to OB/GYN clinic during business hours (Monday – Friday, 8AM – 5PM).
2. Same-Day appointments – if available transfer call to OB/GYN department.
3. Same -Week appointments - if available, Patient Communications ~~and health center~~ may ~~utilize~~ schedule

## V. General Message Principles:

1. For non-urgent messages, send a ~~task~~ Telephone call message in Epic to the Provider Team.
2. Do not change the priority or urgency when tasking the provider’s team.
3. Any urgent messages during business hours will require – Transfer to OBGYN dept ~~office contact or triage.~~

## VI. Referrals:

1. If the patient calls to check on the status or has questions regarding a referral - Transfer call to OBGYN DEPT.
2. If there is an urgent request regarding a referral, please warm transfer to the OB Referral Clerk./OB-GYN DEPT

## VII. Service Programs:

1. Pregnancy Tests:
  - a. Transfer call to clinic.
  - b. Blood pregnancy tests require a lab order and must be requested, please ask patient to contact primary care provider
2. ~~TDAP (Whooping Cough):~~
  - a. ~~Established OB patient advised by OB/GYN provider to get a TDAP (Whooping Cough) vaccine, schedule a nurse visit at any El Rio Health location.~~

## VIII. Triage: Non-Emergent and Emergent Pregnancy Related Symptoms:

1. PC Triage Line: Before 8 a.m. (7:00 a.m. – 7:59 a.m.)
2. Clinic: Between 8 a.m. – 5 p.m.
3. PC Triage Line: After 5 p.m. (5:00 p.m. – 8:00 p.m.)
4. PC Triage Line: The 1<sup>st</sup> and 3<sup>rd</sup> Wednesday of every month, 7 a.m. – 9 a.m.
5. PC Triage Line: Saturday Hours
6. Triage for Post-Partum Patients:
  - a. Clinic: If patient has not been seen for post-partum appointment and is having concerns.
  - b. PC Triage Line: If patient has been seen for post-partum appointment and is having concerns.

## IX. Triage: Non-Pregnancy symptoms

1. See Triage Algorithm

# EL RIO HEALTH

<b>PROCEDURE DESCRIPTION:</b> OB/GYN Appointment Scheduling	<b>REFERENCE NUMBER:</b> PCM-105-SOP-001
<b>PAGE:</b> 5 of 5	<b>EFFECTIVE DATE:</b>

## **X. Insurances, Self-Pay, and Sliding Fee Scales:**

1. Caremore and Tricare (HealthNet Federal):
  - a. If the patient is not the subscriber, obtain Name and Date of Birth of the subscriber.
2. Medical Full Pay and Sliding Fee Scales
  - a. Patients will be quoted the deposit or fee amount when scheduling- when applicable OB/GYN department will contact regarding additional deposits / fees ( if applicable )
3. Private Insurance Plans
  - a. Clinic staff will contact patients regarding any co-pays and / or deductibles before the appointment date

## **REFERENCES:**

# EL RIO HEALTH

**SCOPE:**

This procedure applies to **CLINICAL** and **NON-CLINICAL** departments in the following El Rio Health functional areas and/or locations (check all that apply):

- |  |  |   |  |
|--|--|---|--|
| <input type="checkbox"/> Family Medicine   | <input type="checkbox"/> Same Day Appt. Clinic | <input type="checkbox"/> Radiology              | <input type="checkbox"/> MOR/DOS         |
| <input type="checkbox"/> Internal Medicine | <input type="checkbox"/> HOB/HOU               | <input checked="" type="checkbox"/> Pharmacy    | <input type="checkbox"/> Administration  |
| <input type="checkbox"/> Pediatrics        | <input type="checkbox"/> SIA                   | <input type="checkbox"/> Laboratory             | <input type="checkbox"/> Human Resources |
| <input type="checkbox"/> Dental            |  | <input type="checkbox"/> HIM                    | <input type="checkbox"/> Accounting      |
| <input type="checkbox"/> Behavioral Health | <input type="checkbox"/> Care Coordination     | <input type="checkbox"/> Information Technology | <input type="checkbox"/> Business Office |
| <input type="checkbox"/> Midwives          | <input type="checkbox"/> Wellness              | <input type="checkbox"/> Patient Communications | <input type="checkbox"/> Coding          |
| <input type="checkbox"/> OB/GYN            |  | <input type="checkbox"/> Advocacy & Eligibility | <input type="checkbox"/> Security        |
| <input type="checkbox"/> Clinical Pharmacy |  | <input type="checkbox"/> Facilities/Materials   | <input type="checkbox"/> Transportation  |

<p><b>PROCEDURE DESCRIPTION:</b> Pharmacy Sliding Fee; Co-pay Collection, and Internal Billing Codes</p>	<p><b>PAGE:</b> 1 of 4</p>
	<p><b>REFERENCE NUMBER:</b> PHM-006-SOP-001</p>
<p><b>APPROVAL DATE:</b></p>	<p><b>DATES REVIEWED WITHOUT CHANGE:</b></p>
<p><b>EFFECTIVE DATE:</b></p>	<p><b>REPLACES PROCEDURE DATED:</b> 10/2022:11/2022:07/2023</p>
<p><b>NEXT REVIEW DATE:</b></p>	<p><b>DATE RETIRED:</b> N/A</p>
<p><b>RESPONSIBILITY:</b> Director of Pharmacy</p>	<p><b>APPROVALS:</b> Pharmacy Director: PPC: CAC:</p>

**PURPOSE:** To provide guidelines for the collections of sliding fees or co-pays at the pharmacy when a patient expresses the inability to pay.

**PROCEDURE:**

When a patient expresses the inability to pay, pharmacy staff will refer the patient to eligibility or community health advisor staff to determine financial need.

A. Insurance copays will be determined by the patients’ insurance carrier or pharmacy benefit manager. El Rio Health’s Usual and Customary price is based on the following table:

From Unit Cost (\$)	To Unit Cost (\$)	Markup (%)	Additional Fee (\$)
0.00	0.50	0	8
0.501	1.5	15	18
1.501	999999	20	8

Unit cost is based on the dispense unit (each, gram, tablet/capsule, or mL) price of our non-340b McKesson contract price.

B. The prescription sliding fee schedule will utilize a **five-tier pricing** system. The sliding fee schedule is as follows:

## EL RIO HEALTH

<b>POLICY DESCRIPTION:</b> Pharmacy Sliding Fee-, Co-pay Collection, and Internal Billing Codes	<b>REFERENCE NUMBER:</b> PHM-006-SOP-001
<b>PAGE:</b> 2 of 4	<b>EFFECTIVE DATE:</b>

- C. Full Pay: Patients with income greater than 200% of the Federal Poverty Level (FPL) will be charged their insurance copay payment or the Usual and Customary (U&C) price
- D. Tier 5: Patients with income between 176-200% of the Federal Poverty Level (FPL) will be charged their insurance copay amount, or RX PHARMACY TIER 5 as a secondary payment if there is a financial need, to adjust copay to either \$16 for a 30-day supply or \$21 for a 90-day supply
  - a. If the patient is self-pay RX PPP2 price (Actual Acquisition Cost (ACQ) + \$8.00 dispensing fee will be used.
- E. Tier 4: Patients with income between 151% - 175 % of the Federal Poverty Level (FPL) will be charged their insurance copay amount, or RX PHARMACY TIER 4 as a secondary payment if there is a financial need, to adjust copay to either \$15 for a 30-day supply or \$20 for a 90-day supply.
  - a. If the patient is self-pay RX PPP price (Actual Acquisition Cost (ACQ) + \$7.00 dispensing fee will be used.
- F. Tier 3: Patients with income between 134% - 150% FPL will be charged their insurance copay amount, or RX PHARMACY TIER 3 as a secondary payment if there is a financial need, to adjust copay to either \$11 for a 30-day supply or \$16 for a 90-day supply.
  - a. If patient is self-pay RX DISCOUNT price (Actual Acquisition Cost (ACQ) + \$6.00 dispensing fee will be used.
- G. Tier 2: Patients with income between 101-133% FPL will be charged their insurance copay amount, or RX PHARMACY TIER 2 as a secondary payment if there is a financial need, to adjust copay to either \$10 for a 30-day supply or \$15 for a 90-day supply.
  - a. If the patient is self-pay RX DISCOUNT DISC price (ACQ + \$6.00 dispensing fee will be used.
- H. **Nominal Fee:** Patients with income at or less than 100% FPL will be charged their insurance copay amount, or RX PHARMACY TIER 1 as a secondary payment if there is a financial need, to adjust copay to either \$5 for a 30-day supply or \$10 for a 90-day supply.
  - a. If the patient is self-pay, RX MINIMUM price (ACQ + \$4.00 dispensing fee will be used.
- I. See attached Pharmacy Sliding Fee Scale (SFS) chart for billing and Pay codes
- J. Pharmacy staff may bill non-covered over-the-counter products to over-the-counter RX OTC CASH pay code, sliding fee scale tier does not apply.
- K. Prescriptions prescribed under the Teen Program are excluded from the sliding fee scale and will follow Teen Billing procedure.
- L. El Rio Health employees and dependents using El Rio Health's insurance benefits qualify for RX EMPLOYEE pay code which matches RX PPP pricing.
- M. Internal billing programs (non-adjudicated payor codes) with eligibility determined in Hyperspace will be billed as an insurance if eligibility noted in Hyperspace. The following internal billing programs are:
  - 1. RX STEWART MCKINNEY- 45-day program for homeless population
  - 2. RX OB/GYN – for billing prenatal, iron, docusate, ondansetron only
  - 3. RX TITLE X- uses FPL requirements, to be used at El Pueblo, NW, and Congress locations only
- N. Managed care programs-
  - 1. RX YAQUI – The Yoeme Health Program roster should be checked monthly to determine eligibility. The program only covers El Rio Formulary medications, all other medications

# EL RIO HEALTH

<b>POLICY DESCRIPTION:</b> Pharmacy Sliding Fee, Co-pay Collection, and Internal Billing Codes	<b>REFERENCE NUMBER:</b> PHM-006-SOP-001
<b>PAGE:</b> 3 of 4	<b>EFFECTIVE DATE:</b>

- require a Prior Authorization.
2. RX IHS – following approved list of OTC items

O. Other internal pay codes

1. RX BLOOD GLUCOSE MONITOR- for Free glucose monitors from manufacturer
2. RX BLOOD PRESSURE CUFF- for free blood pressure machines
3. RX CAA- requires documentation from a Community Health advisor or Eligibility department
4. RX EL RIO VOUCHER- to be used only with Pharmacy Administration approval. Pharmacy Managers can authorize if Pharmacy Administrators are not available at the date of service for urgent requests. Pharmacy Managers must notify Pharmacy Administration of approvals. Pharmacy staff will place notes in the profile with approval information and date of approval. Cannot be combined with insurance.

**Pharmacy Accounts Receivable (AR) Accounts:**

El Rio Health Pharmacy will operate in a manner such that no patient shall be denied service due to an individual's inability to pay.

When a patient expresses the inability to pay, pharmacy staff will refer the patient to eligibility or community health advisor staff to determine if the patient qualifies for any assistance programs or the SFS if not already determined. If the patient is ineligible for assistance the patient may utilize an Accounts Receivable account (in house charge account) under their name to place the copayments.

1. It is the responsibility of the Pharmacy staff member checking out the prescriptions to review the billing of each prescription and ensure all prescriptions were correctly billed before placing them on the account.
2. Pharmacy staff will ask patients if they are able to pay a partial amount of the total amount due.
3. Pharmacy staff will explain the billing and collection process to the patient. Patients will receive a billing statement and are responsible for paying the total amount due on the account and can make payments to their account.
4. Pharmacy staff should verify the patient's correct mailing address for billing statements.
5. If patient agrees to the AR account terms the Pharmacy staff will charge any remaining amount due to the in-house account to complete the transaction.
6. Patients will be asked to accept the repayment terms of the in-house account on the customer display screen.
7. If a patient elects not to fill a medication due to cost and is not planning on obtaining the medication elsewhere, the technician will notify the prescribing provider if the medication is an oral antibiotic, insulin, direct oral anticoagulant (apixaban/Eliquis, dabigatran/Pradaxa, edoxaban/Savaysa, rivaroxaban/Xarelto), or antiplatelet P2Y12 inhibitor (clopidogrel/Plavix, prasugrel/Effient, ticagrelor/Brilinta) medication.

**NOTE:** Non-Formulary items cannot be charged to the AR account.

The Pharmacy Administration will set a balance limit for personal AR accounts. Once a patient is at that limit the pharmacy staff checking out the prescriptions will need to work with a pharmacist or

## EL RIO HEALTH

<b>POLICY DESCRIPTION:</b> Pharmacy Sliding Fee; Co-pay Collection, and Internal Billing Codes	<b>REFERENCE NUMBER:</b> PHM-006-SOP-001
<b>PAGE:</b> 4 of 4	<b>EFFECTIVE DATE:</b>

Management to get an override to allow the charges to be added to the account.

The Pharmacists and / or managers will review the medications and amount due to determine if any additional assistance can be offered or if there is a more affordable alternative product available to the patient.

**REFERENCES:**

# EL RIO HEALTH

**SCOPE:**

This procedure applies to **CLINICAL** and **NON-CLINICAL** departments in the following El Rio Health functional areas and/or locations (check all that apply):

- |   |   |   |   |
|---|---|---|---|
| <input checked="" type="checkbox"/> Family Medicine   | <input checked="" type="checkbox"/> Same Day Appt. Clinic | <input checked="" type="checkbox"/> Radiology   | <input checked="" type="checkbox"/> MOR/DOS |
| <input checked="" type="checkbox"/> Internal Medicine | <input checked="" type="checkbox"/> HOB/HOU               | <input checked="" type="checkbox"/> Pharmacy    | <input type="checkbox"/> Administration     |
| <input checked="" type="checkbox"/> Pediatrics        | <input checked="" type="checkbox"/> SIA                   | <input checked="" type="checkbox"/> Laboratory  | <input type="checkbox"/> Human Resources    |
| <input checked="" type="checkbox"/> Dental            |   | <input type="checkbox"/> HIM                    | <input type="checkbox"/> Accounting         |
| <input checked="" type="checkbox"/> Behavioral Health | <input checked="" type="checkbox"/> Care Coordination     | <input type="checkbox"/> Information Technology | <input type="checkbox"/> Business Office    |
| <input checked="" type="checkbox"/> Midwives          | <input type="checkbox"/> Wellness                         | <input type="checkbox"/> Patient Communications | <input type="checkbox"/> Coding             |
| <input checked="" type="checkbox"/> OB/GYN            |   | <input type="checkbox"/> Advocacy & Eligibility | <input type="checkbox"/> Security           |
| <input checked="" type="checkbox"/> Clinical Pharmacy |   | <input type="checkbox"/> Facilities/Materials   | <input type="checkbox"/> Transportation     |

<p><b>PROCEDURE DESCRIPTION:</b> El Rio Health Patient Definition that Meets the Health Resources and Services Administration (HRSA) / Office of Pharmacy Affairs (OPA) Definition</p>	<p><b>PAGE:</b> 1 of 2</p>
	<p><b>REFERENCE NUMBER:</b> PHM-023-SOP-340B-003</p>
<p><b>APPROVAL DATE:</b></p>	<p><b>DATES REVIEWED WITHOUT CHANGE:</b></p>
<p><b>EFFECTIVE DATE:</b></p>	<p><b>REPLACES POLICY DATED:</b> 04/2020:08/2020:03/2022</p>
<p><b>NEXT REVIEW DATE:</b></p>	<p><b>DATE RETIRED:</b> N/A</p>
<p><b>RESPONSIBILITY:</b> Pharmacy Director</p>	<p><b>APPROVALS:</b> PPC: CAC:</p>

**PURPOSE:** To ensure that 340B medications are only dispensed or used for patients that meet HRSA/OPA’s patient definition.

**PROCEDURE:** El Rio **Health** will take safeguards to ensure that 340B medications are only dispensed or used for patients that meet HRSA/OPA’s patient definition.

An individual may be considered an El Rio **Health** patient if they meet current 340B Federal guidelines regarding patient definition:

- the covered entity has established a relationship with the individual, such that the covered entity maintains records of the individual's health care; and
- the individual receives health care services from a health care professional who is either employed by the covered entity or provides health care under contractual or other arrangements (e.g., referral for consultation) such that responsibility for the care provided remains with the covered entity; and

# EL RIO HEALTH

<b>PROCEDURE DESCRIPTION:</b> El Rio Health Patient Definition that Meets the Health Resources and Services Administration (HRSA) / Office of Pharmacy Affairs (OPA) Definition	<b>REFERENCE NUMBER:</b> PHM-023-SOP-340B-003
<b>PAGE:</b> 2 of 2	<b>EFFECTIVE DATE:</b>

- the individual receives a health care service or range of services from the covered entity which is consistent with the service or range of services for which grant funding or Federally qualified health center look-alike status has been provided to the entity.
- An individual will not be considered a patient of the entity for purposes of 340B if the only health care services received by the individual from the covered entity is the dispensing of a drug or drugs for subsequent self-administration or administration in the home setting.

A registered El Rio Health patient must have had an appointment with an El Rio Health provider within the last ~~3~~ two years to be considered an eligible patient for 340B patient eligibility purposes. Various communication will be considered an encounter. It will include but not be limited to clinic visits, face-to-face communication, patient portal messages, telephone calls, TeleHealth (Telemedicine) or any virtual visit completed by providers when care emanates from an eligible El Rio Health site, etc. Visits can be conducted by various licensed healthcare professionals, such as: Medical doctors, doctors of osteopathy, licensed practical nurses, registered nurses, physician ~~assistances~~ assistants, nurse practitioners, pharmacists, dentists, midwives, etc. This communication will be documented in the electronic health record. The visit must fall within El Rio Health's scope of project, as reported to and approved by HRSA's Bureau of Primary Health Care. If an El Rio patient exceeds this ~~three~~ two-year period, the patient will be considered inactive and will be unable to receive any El Rio services (including medications) until the patient reestablishes themselves as an active patient and has an appointment with an El Rio Health provider.

## REFERENCES:

*Federal Register Document 96-27344, Volume 61; No. 207. Notice regarding Section 602 of the Veterans Health Care Act of 1992 Patient and Entity Eligibility*

# EL RIO HEALTH

**SCOPE:**

This procedure applies to **CLINICAL** and **NON-CLINICAL** departments in the following El Rio Health functional areas and/or locations (check all that apply):

- |   |  |   |  |
|---|--|---|--|
| <input type="checkbox"/> Family Medicine              | <input type="checkbox"/> Same Day Appt. Clinic | <input type="checkbox"/> Radiology              | <input type="checkbox"/> MOR/DOS         |
| <input type="checkbox"/> Internal Medicine            | <input type="checkbox"/> HOB/HOU               | <input checked="" type="checkbox"/> Pharmacy    | <input type="checkbox"/> Administration  |
| <input type="checkbox"/> Pediatrics                   | <input type="checkbox"/> SIA                   | <input type="checkbox"/> Laboratory             | <input type="checkbox"/> Human Resources |
| <input type="checkbox"/> Dental                       |  | <input type="checkbox"/> HIM                    | <input type="checkbox"/> Accounting      |
| <input type="checkbox"/> Behavioral Health            | <input type="checkbox"/> Care Coordination     | <input type="checkbox"/> Information Technology | <input type="checkbox"/> Business Office |
| <input type="checkbox"/> Midwives                     | <input type="checkbox"/> Wellness              | <input type="checkbox"/> Patient Communications | <input type="checkbox"/> Coding          |
| <input type="checkbox"/> OB/GYN                       |  | <input type="checkbox"/> Advocacy & Eligibility | <input type="checkbox"/> Security        |
| <input checked="" type="checkbox"/> Clinical Pharmacy |  | <input type="checkbox"/> Facilities/Materials   | <input type="checkbox"/> Transportation  |

<p><b>PROCEDURE DESCRIPTION:</b>                  Provider <b>and Self</b> Referrals for Consultation</p>	<p><b>PAGE:</b> 1 of 3</p> <p><b>REFERENCE NUMBER:</b> PHM-023-SOP-340B-010</p>
<p><b>APPROVAL DATE:</b></p>	<p><b>DATES REVIEWED WITHOUT CHANGE:</b></p>
<p><b>EFFECTIVE DATE:</b></p>	<p><b>REPLACES POLICY DATED:</b> 06/2022:05/2023</p>
<p><b>NEXT REVIEW DATE:</b></p>	<p><b>DATE RETIRED:</b> N/A</p>
<p><b>RESPONSIBILITY:</b> Director of Pharmacy</p>	<p><b>APPROVALS:</b> PPC: CAC:</p>

**PURPOSE:** To ensure that El Rio Health is promoting access to care and quality health outcomes while maintaining 340B compliance, prescriptions written by specialists and other referred clinicians not directly employed by or contracted with El Rio Health may be filled using 340B purchased inventory based on approved eligibility criteria and are subject to minimum documentation standards.

**PROCEDURE:**

In addition to patients seen at Health Resources Services Administration / Office of Pharmacy Affairs (HRSA/OPA) registered sites, by outreach services and via telehealth, El Rio Health routinely refers its patients to a variety of consultant providers to address specific needs and disease states. El Rio Health considers these prescriptions written by referred specialist providers as 340B eligible if the following conditions are met:

- 1- Established (Active) Patient**  
 Patients have had an eligible encounter (See PHM-023-SOP-340B-003) with an eligible provider at an eligible location within the past ~~3~~ **two** years.
- 2- Prescribing provider was referred for consultation**  
 A formal contract is not required for referral of care to other providers / facilities not directly related

# EL RIO HEALTH

<b>PROCEDURE DESCRIPTION:</b> Provider Referrals for Consultation	<b>REFERENCE NUMBER:</b> PHM-023-SOP-340B-010
<b>PAGE:</b> 2 of 3	<b>EFFECTIVE DATE:</b>

to or contracted with El Rio Health.

### 3- Medical records

Medical records of care are maintained for each active patient and responsibility for care remains with El Rio Health. Prescriptions are received from outside clinic and dispensed to an eligible patient will be added to the Electronic Health Record (EHR) to ensure El Rio Health maintains responsibility of the patient's care.

### 4- El Rio Health retains responsibility for the health care service provided to the patient

Patients are active if seen within the last ~~3~~ two years.

### 5- Referral Documentation

#### Located referral

- Documentation of patient's referral is retrievable in the electronic health record (EHR) and / or the referral management portal.
- When El Rio Health remains responsible for an active patient, there is no need for repeat referrals as this creates unnecessary burden on the patient and the medical team. The patient should be seen by the specialist within a year of the original referral date.
- Staff will find referral information in the EHR under Chart Review or in Legacy archives through Galen (Hx EHR)
- If a consultation note is not located in the EHR, El Rio Health will attempt to obtain a consultation note from the outside provider.
- Not locating a consultation note will not prohibit El Rio Health from dispensing medications from outside providers to eligible patients. El Rio Health will attempt to obtain a consultation note from the outside provider to maintain the responsibility of the patient's health care.
- El Rio Health will not accept prescriptions from outside primary care providers when it appears that primary care has been transferred to that provider.

#### Unlocated referral

- If a patient has self-referred or was referred by a previous primary care provider before becoming an established/eligible patient with El Rio Health, or the referral order does not exist in the EHR, there is no need for repeated referrals. El Rio Health ~~will~~ may use a consultation note from the outside provider to confirm maintaining the responsibility of the patient's health care.
- Not finding the referral will not prohibit El Rio Health from filling the prescription ~~as long as there is a consultation note.~~
- El Rio Health will make a good faith effort to obtain consultation notes from the visit and incorporate them into the EHR.
- Outside prescriptions will be included in the patient's medication list in the EHR.
- ~~El Rio Health pharmacy will not accept any prescriptions from urgent care facilities.~~
- ~~El Rio Health pharmacy will accept prescriptions from facilities with signed memorandums of understanding (MOU).~~
- ~~Monthly internal audits will include random selections from specialists' prescriptions to verify referrals or consultation notes are on file.~~

## EL RIO HEALTH

<b>PROCEDURE DESCRIPTION:</b> Provider Referrals for Consultation	<b>REFERENCE NUMBER:</b> PHM-023-SOP-340B-010
<b>PAGE:</b> 3 of 3	<b>EFFECTIVE DATE:</b>

In the event a prescription record does not meet the criteria specified, internal corrective actions may be necessary. If a significant issue of non-compliance is discovered, El Rio Health will decide whether the issue of non-compliance qualifies as a Material Breach of 340B rules / regulations and will report the issue to HRSA. All issues of non-compliance should initiate a plan to pay back manufacturers.

**REFERENCES:** <https://www.hrsa.gov/opa/updates/august-2014.html>

# EL RIO HEALTH

**SCOPE:**

This procedure applies to **CLINICAL** and **NON-CLINICAL** departments in the following El Rio Health functional areas and/or locations (check all that apply):

- |  |  |   |  |
|--|--|---|--|
| <input type="checkbox"/> Family Medicine   | <input type="checkbox"/> Same Day Appt. Clinic | <input type="checkbox"/> Radiology              | <input type="checkbox"/> MOR/DOS         |
| <input type="checkbox"/> Internal Medicine | <input type="checkbox"/> HOB/HOU               | <input checked="" type="checkbox"/> Pharmacy    | <input type="checkbox"/> Administration  |
| <input type="checkbox"/> Pediatrics        | <input type="checkbox"/> SIA                   | <input type="checkbox"/> Laboratory             | <input type="checkbox"/> Human Resources |
| <input type="checkbox"/> Dental            |  | <input type="checkbox"/> HIM                    | <input type="checkbox"/> Accounting      |
| <input type="checkbox"/> Behavioral Health | <input type="checkbox"/> Care Coordination     | <input type="checkbox"/> Information Technology | <input type="checkbox"/> Business Office |
| <input type="checkbox"/> Midwives          | <input type="checkbox"/> Wellness              | <input type="checkbox"/> Patient Communications | <input type="checkbox"/> Coding          |
| <input type="checkbox"/> OB/GYN            |  | <input type="checkbox"/> Advocacy & Eligibility | <input type="checkbox"/> Security        |
| <input type="checkbox"/> Clinical Pharmacy |  | <input type="checkbox"/> Facilities/Materials   | <input type="checkbox"/> Transportation  |

**PROCEDURE DESCRIPTION:**  
Dispensing Esketamine (Spravato™)

**PAGE:**  
1 of 2

**REFERENCE NUMBER:**  
PHM-028-SOP-REMS-Drugs-001

**APPROVAL DATE:**

**DATES REVIEWED WITHOUT CHANGE:**

**EFFECTIVE DATE:**

**REPLACES PROCEDURE DATED:**  
07/2020:05/2021:06/2023

**NEXT REVIEW DATE:**

**DATE RETIRED:**  
N/A

**RESPONSIBILITY:**  
Pharmacy Director

**APPROVALS:**  
PS&T:  
PPC:  
CAC:

**PURPOSE:** To ensure the requirements for dispensing Spravato™ (esketamine) are followed.

**PROCEDURE:**

- A. Becoming certified to dispense
  1. Designate an authorized representative to carry out the certification process and oversee implementation and compliance with the Risk Evaluation and Mitigation Strategies (REMS) Program on behalf of the pharmacy.
  2. Have the authorized representative enroll in the REMS Program by completing the Pharmacy Enrollment Form and submitting it to the REMS Program.
  3. Train all relevant staff involved in dispensing that Spravato™ must only be dispensed to a certified healthcare setting.
  4. Establish processes and procedures to verify that a healthcare setting is certified in the REMS Program before dispensing Spravato™.

## EL RIO HEALTH

<b>PROCEDURE DESCRIPTION:</b> Dispensing Esketamine (Spravato™)	<b>REFERENCE NUMBER:</b> PHM-027-REMS-Drugs-SOP-001
<b>PAGE:</b> 2 of 2	<b>EFFECTIVE DATE:</b>

### B. Dispensing

1. The medication will be by prescription and there will not be a DEA to DEA transfer
2. If ordered by prescription through El Rio pharmacy, the patient accompanied by certified El Rio Health behavioral staff will obtain from pharmacy
3. If ordered by prescription through a specialty pharmacy the medication will be delivered and kept locked in designated med box in the clinic and not in the El Rio pharmacy until the time of administration by the provider.
4. The provider will get a release stating they are authorizing designated El Rio Behavioral Health staff to act as their representative and pick up the medication.
5. Only dispense to El Rio Health behavioral health staff certified through the processes and procedures established as a requirement of the REMS Program.

### C. At all times

1. Do not distribute, transfer, loan, or sell Spravato™ except to certified dispensers.
2. Do not dispense Spravato™ for use outside a certified healthcare setting.
3. Maintain records documenting staff's completion of training. See Appendix A.
4. Maintain records that all processes and procedures are in place and are being followed.
5. Maintain records of all shipments of Spravato™ received and dispensing information including patient name, dose, number of devices, and date dispensed.
6. Comply with audits carried out by Janssen Pharmaceuticals, Inc. or third party acting on behalf of Janssen Pharmaceuticals, Inc. to ensure that all processes and procedures are in place and are being followed.

**REFERENCES:** <https://www.accessdata.fda.gov/scripts/cder/remis/index.cfm?event=IndvRemsDetails.page&REMS=386>

# EL RIO HEALTH

**SCOPE:**

This procedure applies to **CLINICAL** and **NON-CLINICAL** departments in the following El Rio Health functional areas and/or locations (check all that apply):

- |   |   |  |   |
|---|---|--|---|
| <input checked="" type="checkbox"/> Family Medicine   | <input checked="" type="checkbox"/> Same Day Appt. Clinic | <input checked="" type="checkbox"/> Radiology              | <input checked="" type="checkbox"/> MOR/DOS         |
| <input checked="" type="checkbox"/> Internal Medicine | <input checked="" type="checkbox"/> HOB/HOU               | <input checked="" type="checkbox"/> Pharmacy               | <input type="checkbox"/> Administration             |
| <input checked="" type="checkbox"/> Pediatrics        | <input checked="" type="checkbox"/> SIA                   | <input checked="" type="checkbox"/> Laboratory             | <input type="checkbox"/> Human Resources            |
| <input checked="" type="checkbox"/> Dental            |   | <input type="checkbox"/> HIM                               | <input type="checkbox"/> Accounting                 |
| <input checked="" type="checkbox"/> Behavioral Health | <input type="checkbox"/> Care Coordination                | <input type="checkbox"/> Information Technology            | <input checked="" type="checkbox"/> Business Office |
| <input checked="" type="checkbox"/> Midwives          | <input type="checkbox"/> Wellness                         | <input type="checkbox"/> Patient Communications            | <input checked="" type="checkbox"/> Coding          |
| <input checked="" type="checkbox"/> OB/GYN            |   | <input checked="" type="checkbox"/> Advocacy & Eligibility | <input type="checkbox"/> Security                   |
| <input checked="" type="checkbox"/> Clinical Pharmacy |   | <input type="checkbox"/> Facilities/Materials              | <input type="checkbox"/> Transportation             |

<p><b>PROCEDURE DESCRIPTION:</b> Sliding Fee Program</p>	<p><b>PAGE:</b> 1 of 6</p>
	<p><b>REFERENCE NUMBER:</b> PTRG-001-SOP-001</p>
<p><b>APPROVAL DATE:</b></p>	<p><b>DATES REVIEWED WITHOUT CHANGE:</b></p>
<p><b>EFFECTIVE DATE:</b></p>	<p><b>REPLACES PROCEDURE DATED:</b> 04/2022:10/2022:10/2023</p>
<p><b>NEXT REVIEW DATE:</b> (ANNUAL)</p>	<p><b>DATE RETIRED:</b> N/A</p>
<p><b>RESPONSIBILITY:</b> Health Insurance and Community Resources Manager</p>	<p><b>APPROVALS:</b> PPC: CAC: Board:</p>

**PURPOSE:** To provide discounted services to patients and families that fall at or below 200% of the Federal Poverty Level (FPL), both the uninsured and underinsured, for all services within El Rio’s approved scope of services in accordance with Health Resources and Services Administration (HRSA)’s compliance manual.

**Sliding Fee Discount Program:**

No patient will be denied health care services due to an individual’s inability to pay for such services. “Inability to pay” will be defined and implemented within the guidelines provided by the El Rio Health Program requirements. Eligibility is based solely upon family/household size and income level.

Notification: El Rio Health Center will notify patients of the Sliding Fee Discount Program by:

- Notification of the Sliding Fee Discount Program will be offered to each patient upon registration with the Eligibility worker or Eligibility Specialist.

# EL RIO HEALTH

<b>PROCEDURE DESCRIPTION:</b> Sliding Fee Program	<b>REFERENCE NUMBER:</b> PTRG-001-SOP-001
<b>PAGE:</b> 2 of 6	<b>EFFECTIVE DATE:</b>

- Signage at check-in desks and signs all around the clinics
1. All services within the defined scope of the project are eligible for discounting.
  2. Income for the purposes of determining eligibility will include gross amounts (before taxes or expenses) available to the patient. When available, documentation of income will come from a third party such as tax return or pay stub. El Rio Health defines income to include earnings (salaries, wages, tips, professional fees, and financial assistance from outside of the household and other income), and unearned income where no paid work activity is performed (unemployment compensation, workers' compensation, social security, public assistance, Veterans' payments, survivor benefits, short-term and long-term disability benefits, pension or retirement income, interest, dividends, rents, royalties, estates and trusts, education assistance, alimony, and child support).
  3. For patients without this document, a written and signed attestation of income (or no income) will be required.
  4. Family (household) size will include immediate family living in the same household. Family (household) size will also include any persons, related or unrelated, living in the same dwelling and sharing household expenses, e.g., domestic partners, persons, related or unrelated. Those who do not share in household expenses will not be included in the calculation of family (household) income or size.
  3. Evaluation/reevaluation for the Sliding Fee Discount Scale (SFDS) eligibility will occur at least annually. All patients will be asked for family (household) size and family (household) income as part of the required data collection. Patients whose income level changes can ask to be reassessed to see if a lower discount applies to their current income levels.
  4. As a last alternative mechanism for determining patient eligibility for the SFDS, a patient may be seen for services once every 12 months without providing documentation of income (self-declaration), except in special circumstances, such as pandemic, and natural disasters.
  5. All SFDS (medical, dental, laboratory, radiology, behavioral health, Ryan White, etc.) will be updated annually following the release of the new Federal Poverty Levels (FPL). The scales will be reapproved by the El Rio Health Board of Directors annually.
  6. The El Rio Health Board of Directors will set a nominal fee for patients with incomes at or below 100% of FPL. The nominal fee will:
    - a. Be a flat fee.
    - b. Nominal from the patient's perspective, and
    - c. Not reflective of the actual cost of service provided.
  7. The SFDS will be based upon five classes of income:
    - a. Patients at or below 100% of FPL will be eligible for the nominal fee of fifteen dollars (\$15.00) for medical services and Behavioral Health services.
    - b. The dental nominal fee for patients at or below 100% FPL is \$25 plus the dental laboratory fees.

## EL RIO HEALTH

<b>PROCEDURE DESCRIPTION:</b> Sliding Fee Program	<b>REFERENCE NUMBER:</b> PTRG-001-SOP-001
<b>PAGE:</b> 3 of 6	<b>EFFECTIVE DATE:</b>

- c. Patients with incomes over 100% of FPL and up to and equal to 200% of FPL will be divided into four partial discount categories, graduating to lesser discount levels as income increases.
  - d. Patients with incomes in excess of 200% of FPL are not eligible for discounts.
8. Some services that require purchased supplies or equipment such as prescriptions glasses are not considered part of the sliding fee program. Fees for such equipment and purchased services/supplies items will be separate from the discounts applied to services of El Rio Health Center.

Determining the sliding fee discount eligibility according to family size and income:

1. Health-e-Arizona Plus (HEA+) is web-based application for medical coverage for state programs and community discount programs and will be the tool used to determine the FPL for sliding fee. The patient will complete the SFDS application. Discounts will be available for only that date of service and going forward to the date of expiration.
2. Patient income will be assessed based upon the documentation provided:
  - a. IRS 1040 – Adjusted Gross Income (MAGI)
  - b. Social Security Letter – Gross Income multiplied by 12
  - c. Pay stubs
    - i. Determine the pay frequency by circling/highlighting the pay range
    - ii. Determine the gross income by circling/highlighting the gross income from all forms (regular, OT, vacation, holiday, etc.)
    - iii. Average the gross incomes from the stubs
    - iv. Multiply the average for the pay frequency as follows:
      1. 52 (weekly)
      2. 26 (bi-weekly)
      3. 24 (semi-monthly)
      4. 12 (monthly)
3. The Health Insurance and Community Resources Department (HICR) will audit a sample every quarter. This sample is to ensure accuracy & consistency across the program related to assessment/reassessment of patient incomes. This assures that patients will be treated equally and equitably. The results of the audit will be shared with the Finance Committee and El Rio Health Board of Directors.
4. The HICR will provide regular staff training on implementing the SFDS. Such training will seek to correct any issues identified in the audits mentioned above.
5. The SFDS will be evaluated at least once every 3 years for the purpose of identifying and reducing financial barriers to care from the patient’s point of view. The process will include:
  - a. Gathering utilization data for all discount pay classes (using average number of encounters per patient). This data will be reviewed by Senior Leadership and the El Rio Health Board of Directors.
    - i. By services rendered (medical, dental, behavioral health, etc.)
    - ii. Trending over a minimum of two-three years
  - b. Evaluate the data to determine if any barriers to care are present
  - c. Identify and implement any changes based on the data

# EL RIO HEALTH

<b>PROCEDURE DESCRIPTION:</b> Sliding Fee Program	<b>REFERENCE NUMBER:</b> PTRG-001-SOP-001
<b>PAGE:</b> 4 of 6	<b>EFFECTIVE DATE:</b>

REFERENCES:

**El Rio Sliding Fee Scale Income Guidelines 2023 Incl. Ryan White (002) (Board Approved)**

**[PTRG-001 Eligibility and Requirements for Sliding Fee 2019](#)**

**[PTRG-001-SOP-006 Fee Sonograms and Mammograms](#)**

**[PTRG-001-SOP-009 Lab Sliding Fees 2018](#)**

**[BH-ELIG-001 Eligibility Screening](#)**

**[PHM-006-SOP-001 Sliding fee and Co-pay collection](#)**

# EL RIO HEALTH

<b>PROCEDURE DESCRIPTION:</b> Sliding Fee Program	<b>REFERENCE NUMBER:</b> PTRG-001-SOP-001
<b>PAGE:</b> 5 of 6	<b>EFFECTIVE DATE:</b>

El Rio Health - Sliding Fee Sliding Scale 2023 Federal Poverty Guidelines Effective March 1, 2023						
Household Size	0% - 100% FPL	101% - 133% FPL	134% - 150% FPL	151%- 175% FPL	176% - 200% FPL	Over 200% FPL
Dental	\$25 nominal fee + Lab/Supply Costs	50% Discount	40% Discount	30% Discount	20% Discount	No Discount
Laboratory Fees Retinopathy Screening Nutrition Primary Care Behavioral Health/BHC Wellness	\$1	\$5	\$10	\$15	\$20	No Discount
Pharmacy Copay Discount	90-Day=\$10, 30-Day=\$5	90-Day=\$15, 30-Day=\$10	90-Day=\$16, 30-Day=\$11	90-Day=\$20, 30-Day=\$15	90-Day=\$21, 30-Day=\$16	No Discount
Medical, Specialty Behavioral Health, PharmD Vision, Ultrasound/Specialty Radiology, Physical Therapy, etc.	Nominal Fee \$15	\$26	\$30	\$40	\$50	No Discount \$75 Down remaining balance is billed.
1	\$ 0 - \$ 14,580	\$ 14,581 - \$ 19,391	\$ 19,392 - \$ 21,870	\$ 21,871 - \$ 25,515	\$ 25,516 - \$ 29,160	\$ 29,161 and up
2	\$ 0 - \$ 19,720	\$ 19,721 - \$ 26,228	\$ 26,229 - \$ 29,580	\$ 29,581 - \$ 34,510	\$ 34,511 - \$ 39,440	\$ 39,441 and up
3	\$ 0 - \$ 24,860	\$ 24,861 - \$ 33,064	\$ 33,065 - \$ 37,290	\$ 37,291 - \$ 43,505	\$ 43,506 - \$ 49,720	\$ 49,721 and up
4	\$ 0 - \$ 30,000	\$ 30,001 - \$ 39,900	\$ 39,901 - \$ 45,000	\$ 45,001 - \$ 52,500	\$ 52,501 - \$ 60,000	\$ 60,001 and up
5	\$ 0 - \$ 35,140	\$ 35,141 - \$ 46,736	\$ 46,737 - \$ 52,710	\$ 52,711 - \$ 61,495	\$ 61,496 - \$ 70,280	\$ 70,281 and up
6	\$ 0 - \$ 40,280	\$ 40,281 - \$ 53,572	\$ 53,573 - \$ 60,420	\$ 60,421 - \$ 70,490	\$ 70,491 - \$ 80,560	\$ 80,561 and up
7	\$ 0 - \$ 45,420	\$ 45,421 - \$ 60,409	\$ 60,410 - \$ 68,130	\$ 68,131 - \$ 79,485	\$ 79,486 - \$ 90,840	\$ 90,841 and up
8	\$ 0 - \$ 50,560	\$ 50,561 - \$ 67,245	\$ 67,246 - \$ 75,840	\$ 75,841 - \$ 88,480	\$ 88,481 - \$ 101,120	\$ 101,121 and up
Additional Persons	+ \$5,140/person	+ \$6,836/person	+ \$7,710/person	+ \$8,995/person	+ \$10,280/person	+ \$10,280/person

El Rio Health - Sliding Fee Sliding Scale 2023 Federal Poverty Guidelines Effective March 1, 2023						
Household Size	0% - 100% FPL	101% - 133% FPL	134% - 150% FPL	151%- 175% FPL	176% - 200% FPL	Over 200% FPL
Obstetric/Prenatal Package	\$450	\$700	\$800	\$1,000	\$1,500	No Discount
Office Procedures	\$25	\$100	\$150	\$200	\$275	No Discount
Minor Surgery Procedures	\$100	\$550	\$850	\$1,100	\$1,200	No Discount
Major Surgery Procedures	\$250	\$1,500	\$1,600	\$1,800	\$2,000	No Discount
Birth Control Devices	\$25 (\$15 Birth control shot Depo Provera)	50% Discount	40% Discount	30% Discount	20% Discount	No Discount
1	\$ 0 - \$ 14,580	\$ 14,581 - \$ 19,391	\$ 19,392 - \$ 21,870	\$ 21,871 - \$ 25,515	\$ 25,516 - \$ 29,160	\$ 29,161 and up
2	\$ 0 - \$ 19,720	\$ 19,721 - \$ 26,228	\$ 26,229 - \$ 29,580	\$ 29,581 - \$ 34,510	\$ 34,511 - \$ 39,440	\$ 39,441 and up
3	\$ 0 - \$ 24,860	\$ 24,861 - \$ 33,064	\$ 33,065 - \$ 37,290	\$ 37,291 - \$ 43,505	\$ 43,506 - \$ 49,720	\$ 49,721 and up
4	\$ 0 - \$ 30,000	\$ 30,001 - \$ 39,900	\$ 39,901 - \$ 45,000	\$ 45,001 - \$ 52,500	\$ 52,501 - \$ 60,000	\$ 60,001 and up
5	\$ 0 - \$ 35,140	\$ 35,141 - \$ 46,736	\$ 46,737 - \$ 52,710	\$ 52,711 - \$ 61,495	\$ 61,496 - \$ 70,280	\$ 70,281 and up
6	\$ 0 - \$ 40,280	\$ 40,281 - \$ 53,572	\$ 53,573 - \$ 60,420	\$ 60,421 - \$ 70,490	\$ 70,491 - \$ 80,560	\$ 80,561 and up
7	\$ 0 - \$ 45,420	\$ 45,421 - \$ 60,409	\$ 60,410 - \$ 68,130	\$ 68,131 - \$ 79,485	\$ 79,486 - \$ 90,840	\$ 90,841 and up
8	\$ 0 - \$ 50,560	\$ 50,561 - \$ 67,245	\$ 67,246 - \$ 75,840	\$ 75,841 - \$ 88,480	\$ 88,481 - \$ 101,120	\$ 101,121 and up
Additional Persons	+ \$5,140/person	+ \$6,836/person	+ \$7,710/person	+ \$8,995/person	+ \$10,280/person	+ \$10,280/person

# EL RIO HEALTH

<b>PROCEDURE DESCRIPTION:</b> Sliding Fee Program	<b>REFERENCE NUMBER:</b> PTRG-001-SOP-001
<b>PAGE:</b> 6 of 6	<b>EFFECTIVE DATE:</b>

SPECIAL IMMUNOLOGY ASSOCIATES (SIA)	
PAYER RYAN WHITE	
2023 Federal Poverty Guidelines	
Medical, Behavioral Health, Dental, Radiology, Lab, etc.	See Caps on Charges for 201% to 300% FPL and Over 300% FPL. If no income, collect \$0.
Household Size	LESS THAN 400% FPL
1	\$58,320
2	\$78,880
3	\$99,440
4	\$120,000
5	\$140,480
6	\$161,120
7	\$181,680
8	\$202,240

Annual Caps on Charges (HRSA Ryan White)			
Federal Poverty:	Total Charge:	Annual Income (2023 FPL)	Cap:
At or below 100% FPL	\$0	0 to \$14,580	\$0
101% to 200% FPL	No more than 5% gross annual income	>\$14,581 - \$29,160	\$1,458.00
201% to 300% FPL	No more than 7% gross annual income	>\$29,161 - \$43,740	\$3,061.80
Over 300% FPL	No more than 10% gross annual income	>\$43,741	\$4,374.10

# EL RIO HEALTH

**SCOPE:**

This policy applies to **CLINICAL** and **NON-CLINICAL** departments in the following El Rio Health functional areas and/or locations (check all that apply):

- |   |   |  |   |
|---|---|--|---|
| <input checked="" type="checkbox"/> Family Medicine   | <input checked="" type="checkbox"/> Same Day Appt. Clinic | <input checked="" type="checkbox"/> Radiology              | <input checked="" type="checkbox"/> MOR / DOS       |
| <input checked="" type="checkbox"/> Internal Medicine | <input checked="" type="checkbox"/> HOB/HOU               | <input checked="" type="checkbox"/> Pharmacy               | <input checked="" type="checkbox"/> Administration  |
| <input checked="" type="checkbox"/> Pediatrics        | <input checked="" type="checkbox"/> SIA                   | <input checked="" type="checkbox"/> Laboratory             | <input checked="" type="checkbox"/> Human Resources |
| <input checked="" type="checkbox"/> Dental            | <input checked="" type="checkbox"/> Care Coordination     | <input checked="" type="checkbox"/> HIM                    | <input checked="" type="checkbox"/> Accounting      |
| <input checked="" type="checkbox"/> Behavioral Health | <input checked="" type="checkbox"/> Wellness              | <input checked="" type="checkbox"/> Information Technology | <input checked="" type="checkbox"/> Business Office |
| <input checked="" type="checkbox"/> Midwives          | <input checked="" type="checkbox"/> Clinical Pharmacy     | <input checked="" type="checkbox"/> Patient Communications | <input checked="" type="checkbox"/> Coding          |
| <input checked="" type="checkbox"/> OB/GYN            | <input checked="" type="checkbox"/> Facilities            | <input checked="" type="checkbox"/> Advocacy & Eligibility | <input checked="" type="checkbox"/> Security        |
|   | <input checked="" type="checkbox"/> Purchasing            | <input checked="" type="checkbox"/> Physical Therapy       | <input checked="" type="checkbox"/> Transportation  |

**PROCEDURE DESCRIPTION:**

Purchases of Capital Equipment

**PAGE:**

1 of 2

**REFERENCE NUMBER:**

SCM-001-SOP-006

**APPROVAL DATE:**

**DATES REVIEWED WITHOUT CHANGE:**

**EFFECTIVE DATE:**

**REPLACES PROCEDURE DATED:**

12/2021:07/2023

**NEXT REVIEW DATE:**

**DATE RETIRED:**

N/A

**RESPONSIBILITY:**

Procurement Director

**APPROVALS:**

PPC:

CAC:

**PURPOSE:**

To define the process of how to place orders and gain approvals for capital equipment. **Additionally, any purchase will be in accordance with allowable expenses per 45 CFR Part 75 Subpart E.**

**DEFINITIONS:**

Product and Technology Oversight Team (PTOT) – A group of leaders and team members, led and organized by the Procurement Director, to oversee the review and approval or rejection of item master formularies or to review a disposable supply item or piece of equipment being requested to be added for use within El Rio Health.

Formulary – An official list giving details of supplies that may be used / purchased for use that have been approved by the organization.

Approval Hierarchy – Set of rules that determines who can approve a purchase requisition, invoice, or contract, with set parameters for approval dollar limits.

Capital Equipment – Equipment or purchases that extend beyond a certain dollar amount and life expectancy. Refer to FIN-ACCT-007 Health Center Capitalization policy for current limits.

# EL RIO HEALTH

<b>PROCEDURE DESCRIPTION:</b> Purchases of Capital Equipment	<b>REFERENCE NUMBER:</b> SCM-001-SOP-006
<b>PAGE:</b> 2 of 2	<b>EFFECTIVE DATE:</b>

## PROCEDURE:

Capital Equipment Research – When a piece of capital equipment is needed, it is best practice to research a variety of equipment and technology to understand what is available in the market in comparison to your department’s needs. Also required and best practice would be to consider the use of equipment that is already approved for use in the current formulary lists.

For very large capital equipment purchases, generally anything over \$100,000, a Request for Proposal (RFP) is recommended to ensure that the best options and prices are provided for the purchase. Additionally, if the purchase will be completed using Health Resources and Services Administration (HRSA) funds, requirements for how to complete the order will need to be followed, refer to the Compliance department for assistance.

The business unit leader that is looking to purchase the capital equipment is responsible to take ownership of this research and work with other department leaders on input, as necessary. The Supply Chain department is available to assist with recommending contractual supplier options, to gain quotes as needed, and to seek creative options if needed. Other department leaders would also weigh in to assist with the considerations of outcomes, quality, and cost.

Gaining Approval to Purchase – Once the research is finished and the decision is made for what item(s) will be purchased, the approval for purchase and budget must be obtained prior to order placement. The business unit leader should submit the item and quote to their direct leader and the Capital Purchase Committee to review for approval. The direct leader is approving to advance the purchase forward. The Capital Purchase Committee is reviewing and approving to ensure that funds are available to proceed. Once the necessary approvals are completed, the order may be placed.

Capital Purchase Requisition – Placing an order for capital equipment should go through the same **purchasing procedure** as any other required purchase. This ensures that the recorded approvals are obtained, that proper documentation is completed, that there is no conflict of interest in the parties involved, and to keep workflows and efficiencies standardized.

The business unit leader should enter a requisition in the **purchasing system** while attaching the quote and any other approval documents (emails, etc.) to the order to support the purchase. The requisition will then route for approval if needed based on the approval hierarchy. Once the approval is obtained, the Purchasing team will issue a PO for the purchase with the supplier.

\*Exception process: If the capital purchase also requires a contract with it, the process varies. The business unit leader would supply the same documentation such as the quotes and approval emails to the **Contracts Team**. At that point, the **Contracts Team** will obtain any additional paperwork and process the contract for approval from the CEO or CFO. Once the contract is signed, the **Contracts Team** will provide that signed agreement to the Procurement Director, who will then create a PO utilizing the signed contract as the formal approval of the purchase.

# EL RIO HEALTH

**SCOPE:**

This standing order applies to **CLINICAL** and **NON-CLINICAL** departments in the following El Rio Health functional areas and/or locations (check all that apply):

- |   |   |   |  |
|---|---|---|--|
| <input checked="" type="checkbox"/> Family Medicine   | <input checked="" type="checkbox"/> Same Day Appt. Clinic | <input type="checkbox"/> Radiology              | <input type="checkbox"/> MOR / DOS       |
| <input checked="" type="checkbox"/> Internal Medicine | <input type="checkbox"/> HOB/HOU                          | <input checked="" type="checkbox"/> Pharmacy    | <input type="checkbox"/> Administration  |
| <input type="checkbox"/> Pediatrics                   | <input type="checkbox"/> SIA                              | <input type="checkbox"/> Laboratory             | <input type="checkbox"/> Human Resources |
| <input checked="" type="checkbox"/> Dental            | <input type="checkbox"/> Care Coordination                | <input type="checkbox"/> HIM                    | <input type="checkbox"/> Accounting      |
| <input type="checkbox"/> Behavioral Health            | <input type="checkbox"/> Wellness                         | <input type="checkbox"/> Information Technology | <input type="checkbox"/> Business Office |
| <input type="checkbox"/> Midwives                     | <input checked="" type="checkbox"/> Clinical Pharmacy     | <input type="checkbox"/> Patient Communications | <input type="checkbox"/> Coding          |
| <input type="checkbox"/> OB/GYN                       | <input type="checkbox"/> Facilities / Materials           | <input type="checkbox"/> Advocacy & Eligibility | <input type="checkbox"/> Security        |
| <input type="checkbox"/> Referrals                    | <input type="checkbox"/> Purchasing                       | <input type="checkbox"/> Physical Therapy       | <input type="checkbox"/> Transportation  |

<p><b>STANDING ORDER DESCRIPTION:</b>                  Standing Order for SARS-CoV-2 COVID-19 Testing via Sofia 2 Analyzer for Symptomatic El Rio Health Employees and Sister Jose Women’s Outreach</p>	<p><b>PAGE:</b> 1 of 8</p>
<p><b>APPROVAL DATE:</b> 08/2023</p>	<p><b>REFERENCE NUMBER:</b> NUR-024-SOP-SO-038</p>
<p><b>EFFECTIVE DATE:</b> 08/2023</p>	<p><b>DATES REVIEWED WITHOUT CHANGE:</b></p>
<p><b>NEXT REVIEW DATE:</b> 08/2024 (ANNUAL)</p>	<p><b>REPLACES POLICY DATED:</b> 02/2021:04/2022:08/2022</p>
<p><b>RESPONSIBILITY:</b> Medical Director of Infectious Disease Regional Health Center Directors</p>	<p><b>DATE RETIRED:</b> N/A</p>
<p><b>APPROVALS:</b> PPC: 08/2023 CAC: 08/2023</p>	<p><b>Authorized by Chief Clinical Officer (CCO):</b> </p>

**PURPOSE:** To provide medical providers / trained nursing staff (Medical Assistants MA, Licensed Practical Nurses LPN, and Registered Nurses RN) with a standing order for the collection of SARS-CoV-2 COVID-19 testing using the Sofia 2 Analyzer for Symptomatic El Rio Health Employees and Sister Jose Women’s Outreach residents.

Trained nursing staff member (MA, LPN, RN) demonstrating competency should obtain the NP swab sample. Competency will be demonstrated by annual completion of Lippincott Procedure [“NP specimen collection, El Rio”](#)

**The SARS-CoV-2 COVID-19 Test via Sofia 2 Analyzer is only performed by nursing staff who have been trained by the Point of Care (POC) Coordinator and has their annual competency renewal each year.**

# EL RIO HEALTH

<b>STANDING ORDER DESCRIPTION:</b> Standing Order for SARS-CoV-2 COVID-19 Testing via Sofia 2 Analyzer for Symptomatic El Rio Health Employees and Sister Jose Women's Outreach	<b>REFERENCE NUMBER:</b> NUR-024-SOP-SO-038
<b>PAGE:</b> 2 of 8	<b>EFFECTIVE DATE:</b> 08/2023

Depending on a positive or negative COVID-19 results from the Sofia 2 Analyzer, a second nasopharyngeal swab specimen collection for SARS-CoV-2 COVID-19 Reverse transcriptase Polymerase Chain Reaction (RT-PCR) Testing may be required for confirmation testing. Refer to [NUR-024-SOP-SO-036 Standing Order for Collection of SARS-CoV2 COVID-19-Reverse transcriptase Polymerase Chain Reaction \(RT-PCR\) Testing](#)

## PROCEDURE:

1. Obtain and verify printed provider order for Rapid SARS-CoV-2 COVID-19 Testing using the Sofia 2 Analyzer. A second order may be needed for SARS-CoV-2 COVID-19 nasopharyngeal collection if results from the Sofia 2 Analyzer are negative.
2. Consent must be signed. Consents are located on SharePoint under Coronavirus COVID-19 Updates→Current Workflows [COVID-19 Informed Consents-English and Spanish](#)
3. Gather supplies:
  - a. **For Rapid SARS-CoV-2 COVID-19 Testing using the Sofia 2 Analyzer:**
    - 1) Use Sofia 2 SARS Antigen Kit
  - b. **For SARS-CoV-2 COVID-19-Reverse transcriptase Polymerase Chain Reaction (RT-PCR) confirmation testing**, obtain items from the lab. (See Attachment B for example of swab and viral media for Sonora Quest and Lab Corp)
    - 1) (1)- Sterile Polyester tip plastic shaft nasopharyngeal swabs only.
    - 2) (1)-Viral Transport Media 3 ml.
  - c. Appropriate size gloves
  - d. N95 facemask - appropriate size
  - e. Surgical mask (if available for patient)
  - f. Protective eye wear (goggles or face shield)
  - g. Gown
  - h. Tissues
  - i. Penlight
  - j. Perform hand hygiene.
4. Put on (don) gown, N95 facemask, goggles or face shield and non-sterile gloves, to comply with droplet precautions.
5. Identify person using at least 2 identifiers.

## EL RIO HEALTH

<b>STANDING ORDER DESCRIPTION:</b> Standing Order for SARS-CoV-2 COVID-19 Testing via Sofia 2 Analyzer for Symptomatic El Rio Health Employees and Sister Jose Women's Outreach	<b>REFERENCE NUMBER:</b> NUR-024-SOP-SO-038
<b>PAGE:</b> 3 of 8	<b>EFFECTIVE DATE:</b> 08/2023

6. Explain the procedure, to increase their understanding, allay their fears, and enhance cooperation.
7. Verify with employee/patient that printed lab specimen label is correct. Have patient/parent or patient's guardian initial lab specimen label(s) to ensure patient's correct identification of name and date of birth.
8. Explain that they may gag or feel the urge to sneeze during the specimen collection but that the procedure takes about 1 minute.
9. **Nasal Swab Specimen Collection for Sofia 2 Analyzer testing: (See Attachment A)**
  - a. If the person has a lot of mucus, this can interfere with collection. Have them use a tissue to gently wipe the nasal passages before swab is taken and discard.
  - b. Have the person cover their mouth with either a new tissue or surgical mask
  - c. Open the package and remove the swab, taking care not to touch the tip to any surface or lay it down.
  - d. Hold the swab with fingers placed on the score line. With the person seated, tilt the head back 70 degrees, and support the back of the head with non-dominant hand.
  - e. Gently insert the sterile swab until resistance is met at the level of the turbinates (less than one inch into the nostril).
  - f. Place patient initialed lab specimen labels on specimen(s) container. at the bedside in front of the patient/parent or patient's guardian on end of swab and immediately take swab with sample to SOFIA analyzer to run test.
  - g. Perform Rapid SARS-CoV-2 COVID-19 Testing via the Sofia 2 Analyzer per El Rio Health Laboratory Point of Care Test (POCT) Policies and Procedures>Lab/POCT>Specialty Tests. [Sofia 2 SARS Antigen FIA Test-For Employee Contact Tracing Only](#)
10. **Process for results from Sofia 2 Analyzer testing:**
  - a. If results are **positive**: no further testing is needed but follow steps 14 through 15 and steps 20 through 22.
  - b. If results are **negative**: perform a Nasal Pharyngeal Specimen Collection for SARS-CoV-2 COVID-19-Reverse transcriptase Polymerase Chain Reaction (RT-PCR) test for confirmation testing. Refer to steps 10 through 22.
11. **Nasal Pharyngeal Specimen Collection for SARS-CoV-2 COVID-19-Reverse transcriptase Polymerase Chain Reaction (RT-PCR) confirmation testing:** Also refer to Refer to nursing

# EL RIO HEALTH

<b>STANDING ORDER DESCRIPTION:</b> Standing Order for SARS-CoV-2 COVID-19 Testing via Sofia 2 Analyzer for Symptomatic El Rio Health Employees and Sister Jose Women's Outreach	<b>REFERENCE NUMBER:</b> NUR-024-SOP-SO-038
<b>PAGE:</b> 4 of 8	<b>EFFECTIVE DATE:</b> 08/2023

procedure: [NUR-017-SOP-LS-006- Nasopharyngeal Swab Specimen Collection for SARS-CoV-2 COVID-19 and Respiratory Virus Panel Testing \(See Attachment A\)](#)

- a. If the person has a lot of mucus, this can interfere with collection. Have them use a tissue to gently wipe the nasal passages before swab is taken and discard.
  - b. Have the person cover their mouth with either a new tissue or surgical mask (dependent on supplies).
  - c. Open the package and remove the swab, taking care not to touch the tip to any surface or lay it down.
  - d. Hold the swab with fingers placed on the score line. With the person seated, tilt the head back 70 degrees, and support the back of the head with non-dominant hand.
  - e. Gently insert swab into nostril along the septum floor of the nose extending straight back until the posterior nasopharynx is reached (distance from nostrils to external opening of ear). For pediatric patients, if you experience any difficulty passing the swab into the nasopharynx, stop the procedure and notify a provider.
  - f. Slowly rotate the swab several times while the swab is in contact with the nasopharyngeal wall and remove.
12. Place swab into viral media and break the swab inside the viral media transport tube. (See **Attachment B** for instructions for Sonora Quest and Lab Corp, depending on receiving lab.)
  13. Place patient initialed lab specimen labels on specimen(s) container. at the bedside in front of the patient/parent or patient's guardian.
  14. Place correctly labeled specimen container in plastic specimen bag.
  15. Wipe the transport bag with a clinically approved COVID-19 disinfectant if contamination of bag is suspected.
  16. Remove (doff) and discard your gown and gloves.
  17. **Outside of the exam room or direct collection area:**
    - a. Disinfect eye protective equipment after each use. Remove N95 or surgical mask.
    - b. Perform hand hygiene.
  18. Immediately transport SARS-CoV-2 COVID-19 specimen to lab in a biohazard bag.
  19. If the specimen is taken to the lab after it is closed, including Saturday, make sure the specimen is

# EL RIO HEALTH

<b>STANDING ORDER DESCRIPTION:</b> Standing Order for SARS-CoV-2 COVID-19 Testing via Sofia 2 Analyzer for Symptomatic El Rio Health Employees and Sister Jose Women's Outreach	<b>REFERENCE NUMBER:</b> NUR-024-SOP-SO-038
<b>PAGE:</b> 5 of 8	<b>EFFECTIVE DATE:</b> 08/2023

placed in the refrigerator.

20. The SARS-CoV-2 COVID-19 Specimen may be in the lab refrigerator for up to 72 hours if needed.
21. Discard used supplies in regular trash, unless visibly soiled or otherwise directed.
22. Document the procedure in the person's electronic health record and the Sofia 2 SARS Antigen FIA log.
23. **SARS-CoV-2 COVID-19 Testing for Sister Jose Women's Outreach.**
  - a. Women experiencing homelessness seeking shelter at the Sister Jose Women's Outreach will get both the nares swab for Rapid SARS-CoV-2 COVID-19 Testing using the Sofia 2 Analyzer and the nasopharyngeal swab collection for SARS-CoV-2 COVID-19 for RT-PCR testing.
  - b. Follow procedure steps 8 through 20.
  - c. The specimen collections will be taken to the El Pueblo Health Center for processing.
  - d. Document the procedure in the person's electronic health record and the Sofia 2 SARS Antigen FIA log.

## REFERENCES:

NP Specimen Collection, El Rio Health

<https://procedures.lww.com/lnp/view.do?pId=5704598&disciplineId=7383>

[2022 Wolters Kluwer Health Inc., Lippincott Procedures-Nasopharyngeal Specimen Collection, Revised November 18, 2021.https://procedures.lww.com/lnp/view.do?pId=4249518](https://procedures.lww.com/lnp/view.do?pId=4249518)

[Sofia 2 SARS Antigen FIA Test-For Employee Contact Tracing Only](#)

# EL RIO HEALTH

**STANDING ORDER DESCRIPTION:**  
Standing Order for SARS-CoV-2 COVID-19 Testing  
via Sofia 2 Analyzer for Symptomatic El Rio Health  
Employees and Sister Jose Women's Outreach

**REFERENCE NUMBER:**  
NUR-024-SOP-SO-038

**PAGE:** 6 of 8

**EFFECTIVE DATE:** 08/2023

## Attachment A

# How To ...

Obtain nasal/nasopharyngeal swab,  
nasal/nasopharyngeal wash/aspirate specimens\*

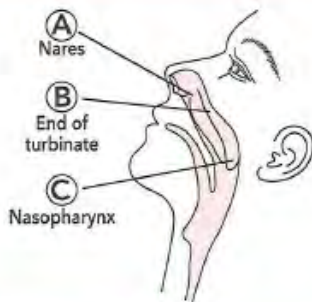

In each case, collect samples by standard clinical methods.

*Tip the patient's head back and check to see which nostril has more mucus (head should be inclined from vertical as shown for proper specimen collection). It is important to obtain as much secretion as possible.*

### NASAL SWAB

1. Gently insert the sterile swab until resistance is met at the level of the turbinates (less than one inch into the nostril).
2. Rotate the swab a few times against the nasal wall and remove from nostril.
3. Sample should be tested as soon as possible.

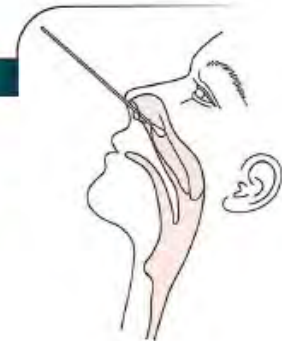

### NASOPHARYNGEAL SWAB

1. Gently insert the sterile swab.
2. Keep the swab near the septum floor of the nose while gently pushing the swab into the posterior nasopharynx.
3. Rotate the swab several times and remove from nostril.
4. Sample should be tested as soon as possible.



See reverse side for nasal/nasopharyngeal wash/aspirate specimen collection

# EL RIO HEALTH

**STANDING ORDER DESCRIPTION:**  
Standing Order for SARS-CoV-2 COVID-19 Testing via Sofia 2 Analyzer for Symptomatic El Rio Health Employees and Sister Jose Women's Outreach

**REFERENCE NUMBER:**  
NUR-024-SOP-SO-038

**PAGE:** 7 of 8

**EFFECTIVE DATE:** 08/2023

## Attachment B

### Sonora Quest Nasopharyngeal Specimen Collection

#### Nasopharyngeal Specimen Collection

COVID-19 Testing with SARS-CoV-2-RNA, Qualitative Real-Time RT-PCR

The test has not been FDA cleared or approved or authorized. The test has been validated according to CLIA, but the FDA's independent review of this validation is pending.

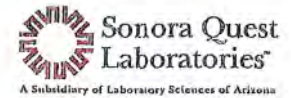

1



Open the individual collection package that contains the swab and Viral Transport Medium tube. Set the tube aside before beginning to collect the specimen.

5

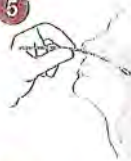

As a visual reference, the swab should be inserted about half the distance from the opening of the patient's nostril and the ear.

Rotate the swab several times.

2



Open the collection swab wrapper by peeling open the top of the wrapper.

Remove the swab, taking care not to touch the tip of the swab or lay it down.

6

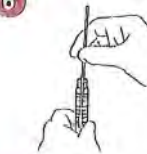

While holding the swab in the same hand, aseptically remove the cap from the tube.

Insert the swab into the tube with the transport medium.

3



Hold the swab in your hand, placing your thumb and forefinger in the middle of the swab shaft across the scoreline.

7



Identifying the scoreline, break the swab shaft against the side of the tube. If needed, gently rotate the swab shaft to complete the breakage.

Discard the top portion of the swab shaft.

Avoid splashing contents on the skin. Wash with soap and water if exposed.

4



Gently insert the swab into the nostril. Keep the swab near the septum floor of the nose while gently pushing the swab into the post nasopharynx.

8



Replace the cap onto the tube and close lightly. Discard the top portion of the swab shaft.

Samples should be stored and transported refrigerated to Sonora Quest Laboratories and are stable at this temperature for 72 hours. Ice packs must be used if placing specimens in a lockbox for courier pick-up. SARS-CoV-2 RNA, Qualitative Real-Time RT-PCR test is not a STAT test and STAT pick-up cannot be ordered.

See additional specimen collection information on back.

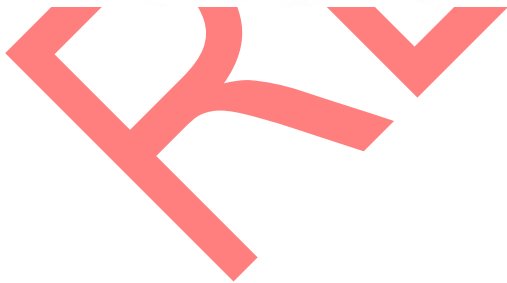

# EL RIO HEALTH

## STANDING ORDER DESCRIPTION:

Standing Order for SARS-CoV-2 COVID-19 Testing via Sofia 2 Analyzer for Symptomatic El Rio Health Employees and Sister Jose Women's Outreach

## REFERENCE NUMBER:

NUR-024-SOP-SO-038

PAGE: 8 of 8

EFFECTIVE DATE: 08/2023

## Lab Corp Nasopharyngeal Specimen Collection

### Nasopharyngeal (NP) specimen collection for COVID-19 testing

1

- Assemble the supplies needed. For sample collection, have the swab and viral transport medium, specimen label, and biohazard bag available.
- If the patient has a lot of mucus in the nose, this can interfere with collection. Have the patient use a tissue to gently clean the nasal passage before a swab is taken.

2



- Open the swab container and remove the swab, taking care not to touch the tip to any surface or lay it down.
- DO NOT use the swabs that come with the viral transport medium kit.**



Depicted is an example of the supplies used to collect a nasopharyngeal specimen.\*

3



- Hold the swab with fingers placed on the score line. With the patient seated, if possible, tilt the head back 70 degrees, support the back of the head with your non-dominant hand.
- Gently insert swab into the nostril along the septum floor of the nose extending straight back **until the posterior nasopharynx is reached** (distance from nostrils to external opening of ear).
- Rotate the swab several times while the swab is in contact with the nasopharyngeal wall.

4



- Place NP swab into the viral transport medium and break (snap) off swab at the indicator line. Replace cap and screw cap on securely.

5

- Label sample and place in biohazard bag.
- Freeze specimen and keep frozen.
- Submit sample on one requisition, with test code 139900 — COVID-19. Please include the patient's address, phone number and appropriate diagnosis code. To avoid delays in turnaround time when requesting multiple tests on frozen samples, please submit separate frozen specimens for each test requested.

**Storage Transport Condition** - Samples/specimens should be shipped frozen due to limited stability at -20° C (preferred); refrigerated specimens acceptable (if received for testing within 72 hours of collection). Refrigerated swabs submitted within 72 hours will be accepted.

\*Exact manufacturer of the swab and transport media may vary with supply. Any swab of appropriate size and configuration with a synthetic tip can be used, **EXCEPT** for calcium alginate tips, swabs with preservatives, and swabs with wood shafts. Viral transport media acceptable for collection of Influenza specimens in 1 mL or 3 mL volumes can be used to transport swabs for COVID-19 testing.

