

PATHFINDER MODEL





PATHFINDER **TIGER** **MODEL S OVERVIEW**

Utilizes existing production pallets, return conveyors, frontal product delivery conveyors and most existing molds

Capable of producing a wide range of products (from 2-3/8" up to 8-15/32")

Simple and quick mold change system; which releases the mold compression head directly

Allows for height changes in only an additional 2 minutes

Advanced, user-friendly controls

Can be placed on most existing machine foundations

Frequency control on vibrators

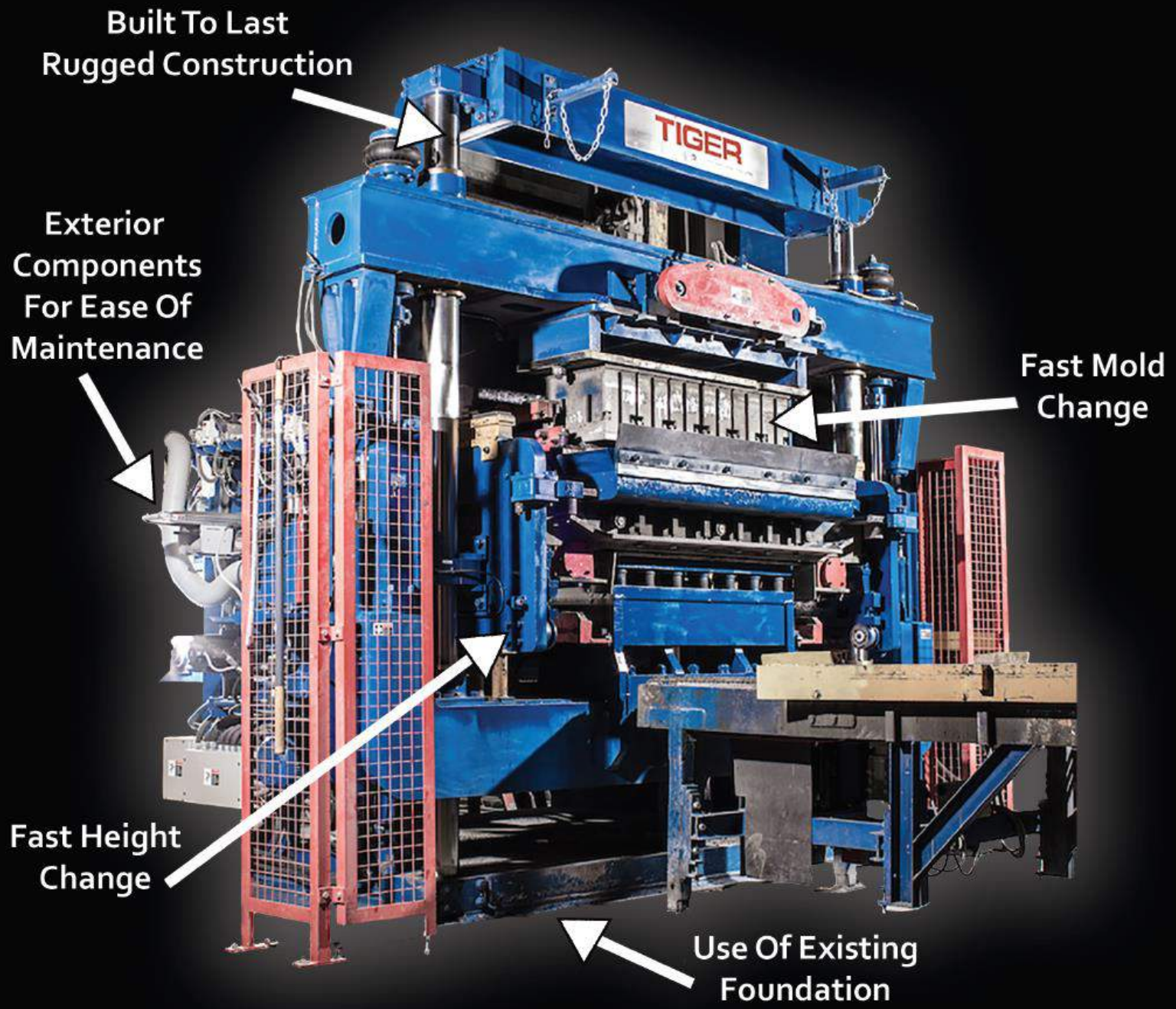

**Built To Last
Rugged Construction**

**Exterior
Components
For Ease Of
Maintenance**

**Fast Mold
Change**

**Fast Height
Change**

**Use Of Existing
Foundation**



PATHFINDER

TIGER

MOLD CHANGE SYSTEM

The S Series is equipped with a quick mold change system which releases the mold compression head directly. This is done from the control panel, requiring only the manual release of V-belts. The release is aided by a hydraulically operated inflation system (air bags) for the mold. The mold delivery system is also panel actuated and hydraulically operated. This will allow for mold changes in a shorter amount of time.

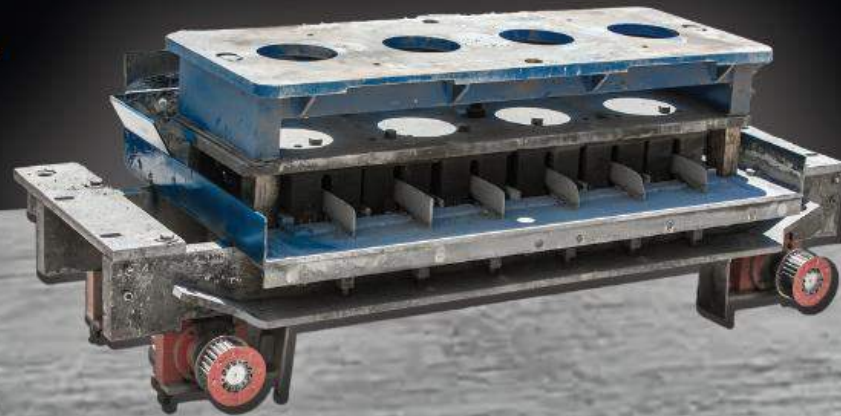

PATHFINDER TIGER CONTROLS

User-friendly
Ease In Operation
Highly Adjustable
Mold Life Reporting
Production Reporting



PATHFINDER **TIGER** DIMENSIONS

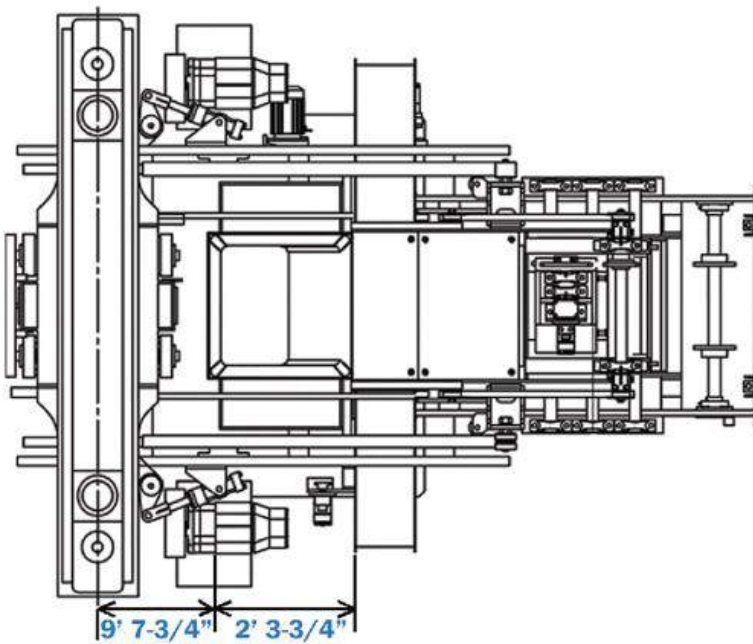
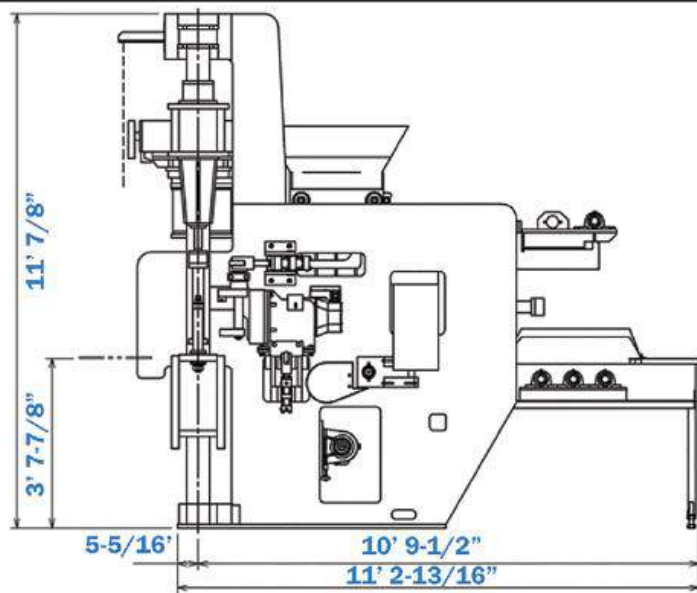
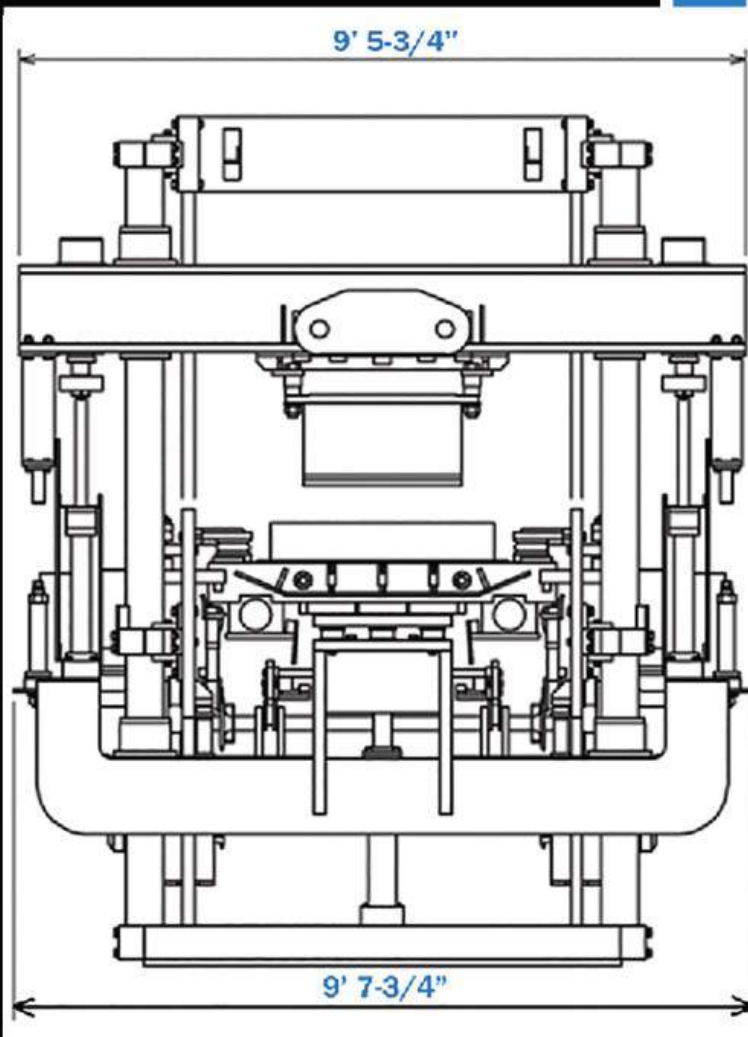

PATHFINDER TIGER

MODEL S SPECIFICATIONS

| SERIES | S-3 | S-4 | S-6 |
|--------------------------------|-----------------------------|-----------------------------|----------------------------|
| FEATURES | | | |
| Vibration Motors (HP) | 20 HP x 2 PC. | 20 HP X 2 pc. | 30 HP X 2pc. |
| Agitator | Swing | Swing | Swing |
| Pump Motor - (HP) | 60 HP | 60 HP | 73 HP |
| CAPACITY | | | |
| Steel Pallet Size - Inches | 26"W x 18.5"L x 5/18" | 38.5"W x 18.5"L x 15/32" | 52"W x 18.5"L x 5/8" |
| Usable Mold Cavity - Inches | 25.6"W x 17.7"L x 2.36-8.5" | 37.5"W x 17.7"L x 2.36-8.5" | 51.2"W x 17.7L x 2.36-8.5" |
| PRODUCTIVITY | | | |
| Max Dry Cycle Speed In Seconds | 3.6 | 3.9 | 4.3 |
| Max Wet Cycle Speed In Seconds | 6 | 6.2 | 6.5 |
| UNITS/CYCLE/PALLET | | | |
| 10 cm/4" Block | 6 | 9 | 12 |
| 12 cm/5" Block | 5 | 7 | 10 |
| 15 cm/6" Block | 4 | 6 | 8 |
| 19 cm/8" Block | 3 | 4 | 6 |
| 25 cm/10" Block | 2 | 3 | 5 |
| 29 cm/12" Block | 2 | 3 | 4 |
| Holland Stone Paver-100x200mm | 12 | 16 | 24 |
| WEIGHT | | | |
| Weight | 6,800 LBS | 8,600 LBS | 10,450 LBS |



PATHFINDER

For more information on the Model S or any of the following Pathfinder services:

- Batch Plants
- Curing Systems
- Molds & Mold Parts
- Grinding & Polishing
- Paver Laying Equipment
- Block & Paver Manufacturing
- Pipe & Manhole Manufacturing
- Predictive Maintenance Sensors

Email: Sales@PathfinderSystem.com
Or Call Us: (616) 395-8447



695 Ottawa Beach Rd, Holland, MI 49424
PathfinderSystem.com