

WELCOME

Keeping Workers Safe Around Machines

Objectives

During this webinar, we will discuss:

- Common hazards of machines
- Photographs of improperly or unguarded machines
- Explain adequate machine safeguarding options, and
- Offer steps for moving forward



Why Machines Must Be Properly Guarded

- 800 deaths each year
- High injury rates
 - Amputations, fractures, lacerations, and crushing
 - Electric shock and burns

OSHA Requirements

- 1910.211 – definitions
- 1910.212 – General Requirements
 - One or more methods
 - Protect operator and other employees
 - From hazards created by point of operation, ingoing nip points, rotating parts, flying chips and sparks
 - Protection may include: barrier guards, two hand tripping devices, electronic safety devices, etc.

Additional Standards

1. 1910.213 – 1910.244 (Subpart O0)
 1. Woodworking
 2. Cooperage
 3. Abrasive Wheel
 4. Mills and Calenders
 5. Power Presses including certification/validation of safety systems for presence sensing device
 6. Forging machines
 7. Mechanical Power Transmission Apparatus
 1. Projecting shaft ends

Poll Question

- True or False?
- If the machine is old or is being used as provided by the manufacturer, then the safe guarding is always satisfactory.

Safeguard Classifications

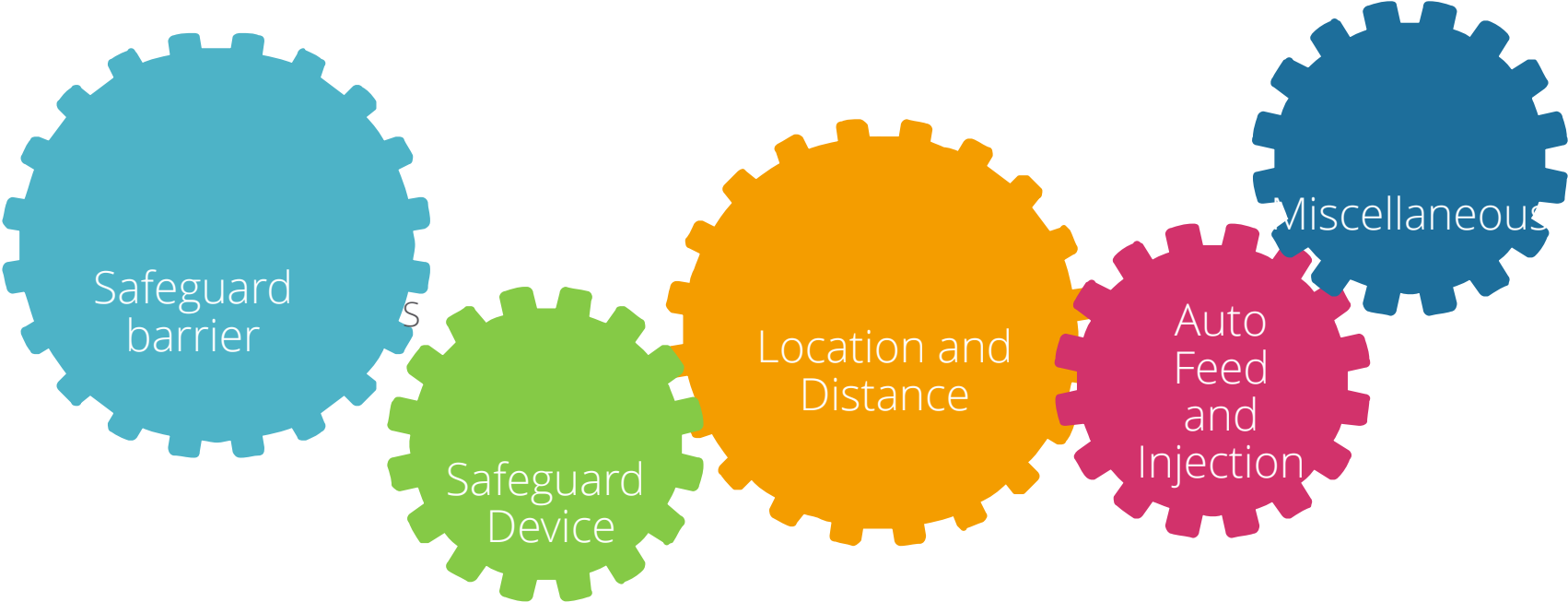

Effective Machine Guards/Safeguard Barrier

- Prevent contact with hazard zones
- Are secure
 - Fasteners require tool for removal (best practice)
- Create no new hazard
- Do not create interference
- Allow for safe lubrication
- Withstand work conditions
- Allow for safe routine maintenance



Point of Operation Functions

- Cutting
- Punching
- Shearing
- Bending
- Compressing

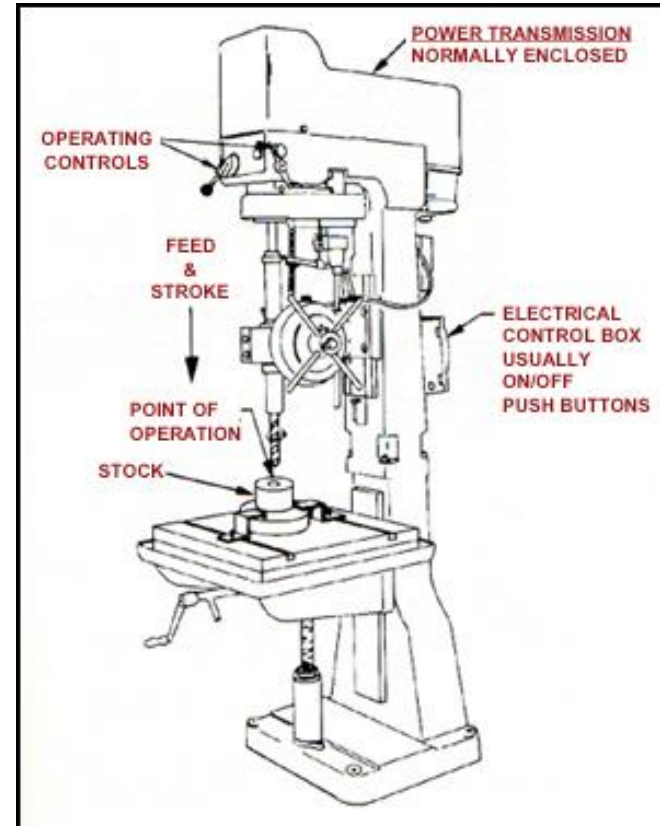

Cutting Machines and Actions

- Hazard—Cutting action, flying chips, or scrap material cut fingers or strike the head or body
- Machines
 - Band and circular saws
 - Boring or drilling
 - Lathes and milling
- Actions
 - Rotating, reciprocating, or transverse motion



Cutting Machines

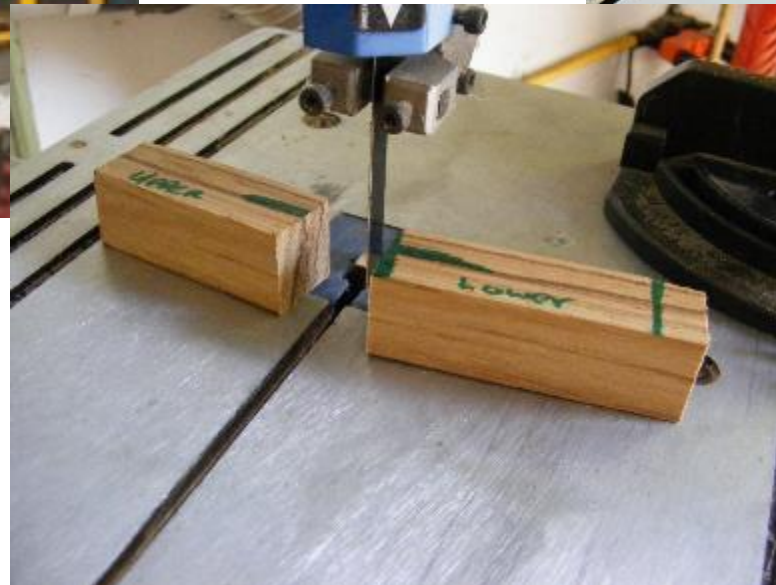

Milling Machines



Punching Machines and Actions

- Hazard—Fingers can be crushed where material is inserted, held, or withdrawn
- Machines
 - Power presses
 - Ironworking equipment
- Action of ram mechanism
 - Bending, drawing, or stamping

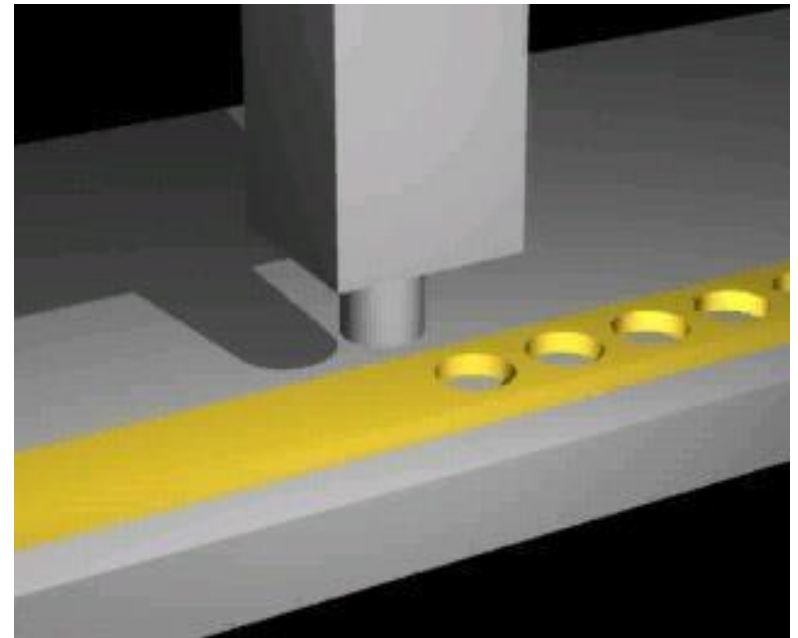

Punching Machines Example



Shearing Machines and Actions

- Hazard—Crush or tear body parts where material is inserted, held, or withdrawn
- Machines:
 - Hydraulic shears
 - Mechanical shears
 - Pneumatic shears
- Actions
 - Powered slide or knife to trim or shear metal or other materials

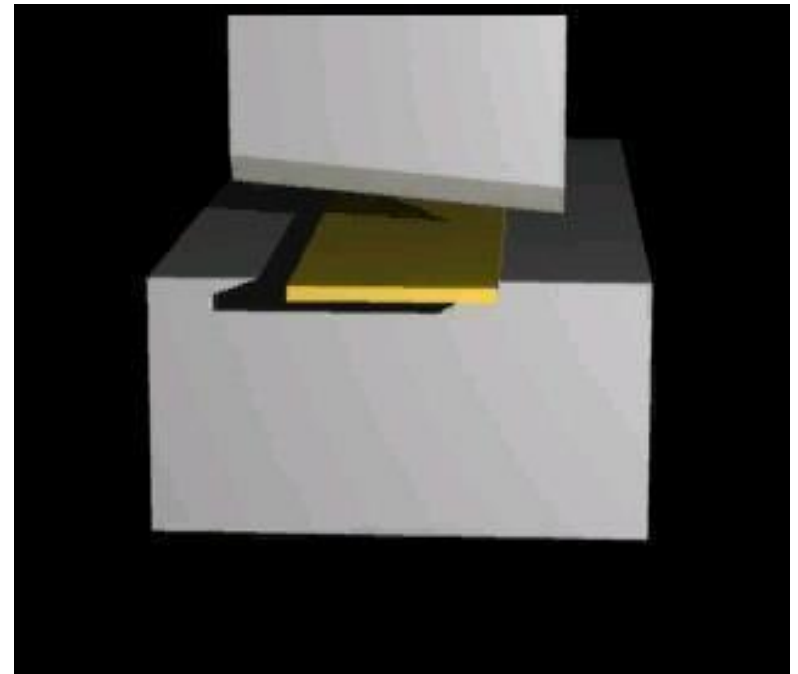

Shearing Machines Example



Bending Machines and Actions

- Hazard—Crushing body parts where material is inserted, held, or withdrawn
- Machines
 - Power presses and press brakes
 - Tubing benders
- Actions
 - Draw or stamp

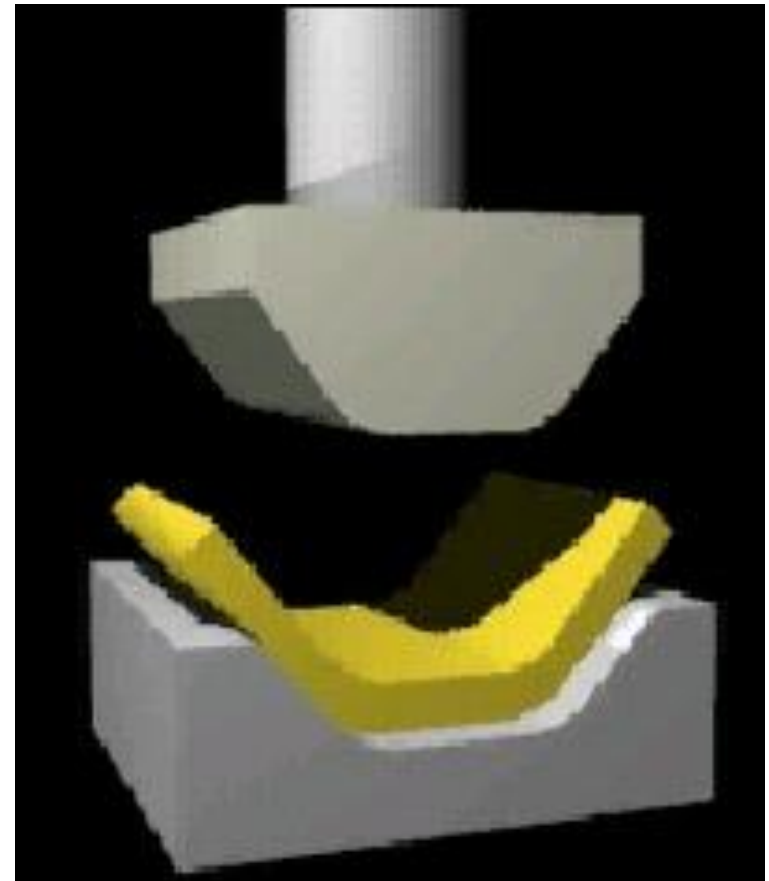

Bending Machines Example

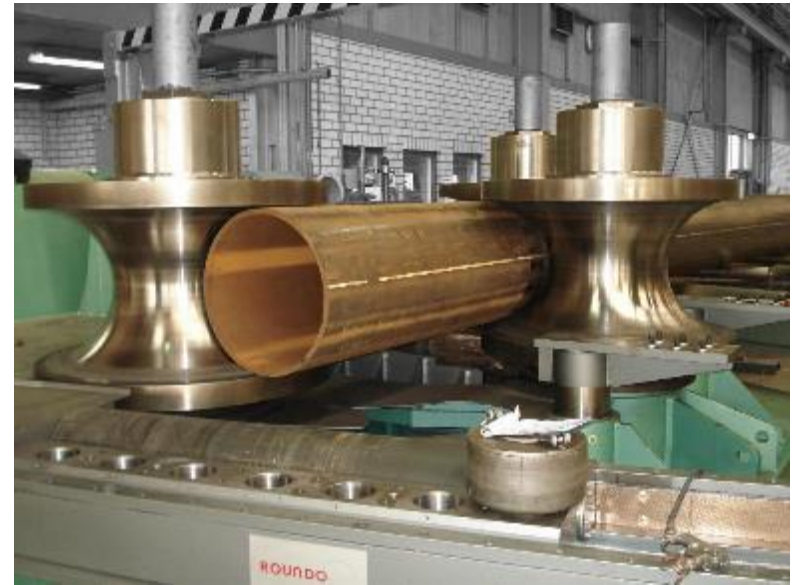

Compressing Machines and Actions

- Hazard—Compression crushes body parts
- Machines
 - Compactor (*example: trash compactor in maintenance*)
 - Molding
- Actions
 - Squeezing, extruding, and pressing

Compressing Machines Example

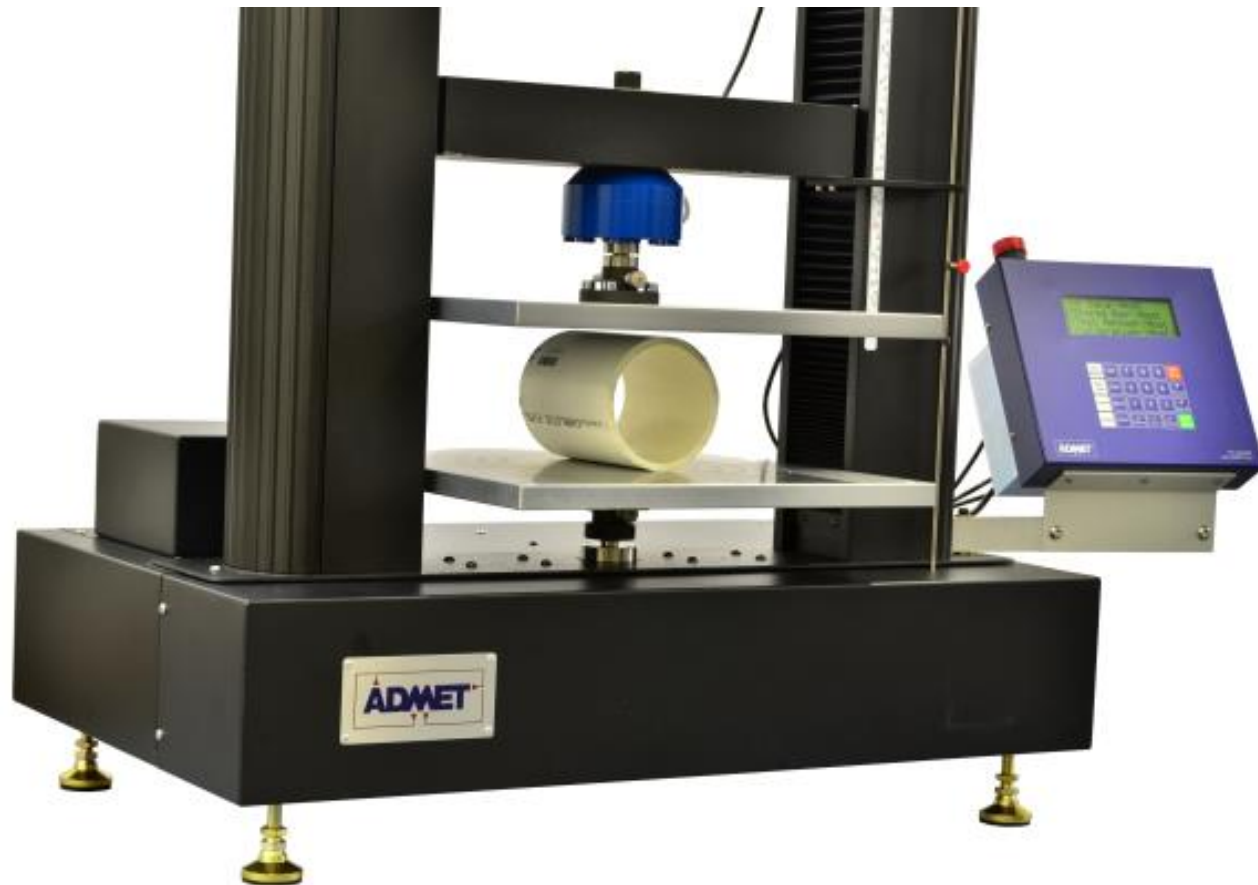

Horizontal Injection Molding

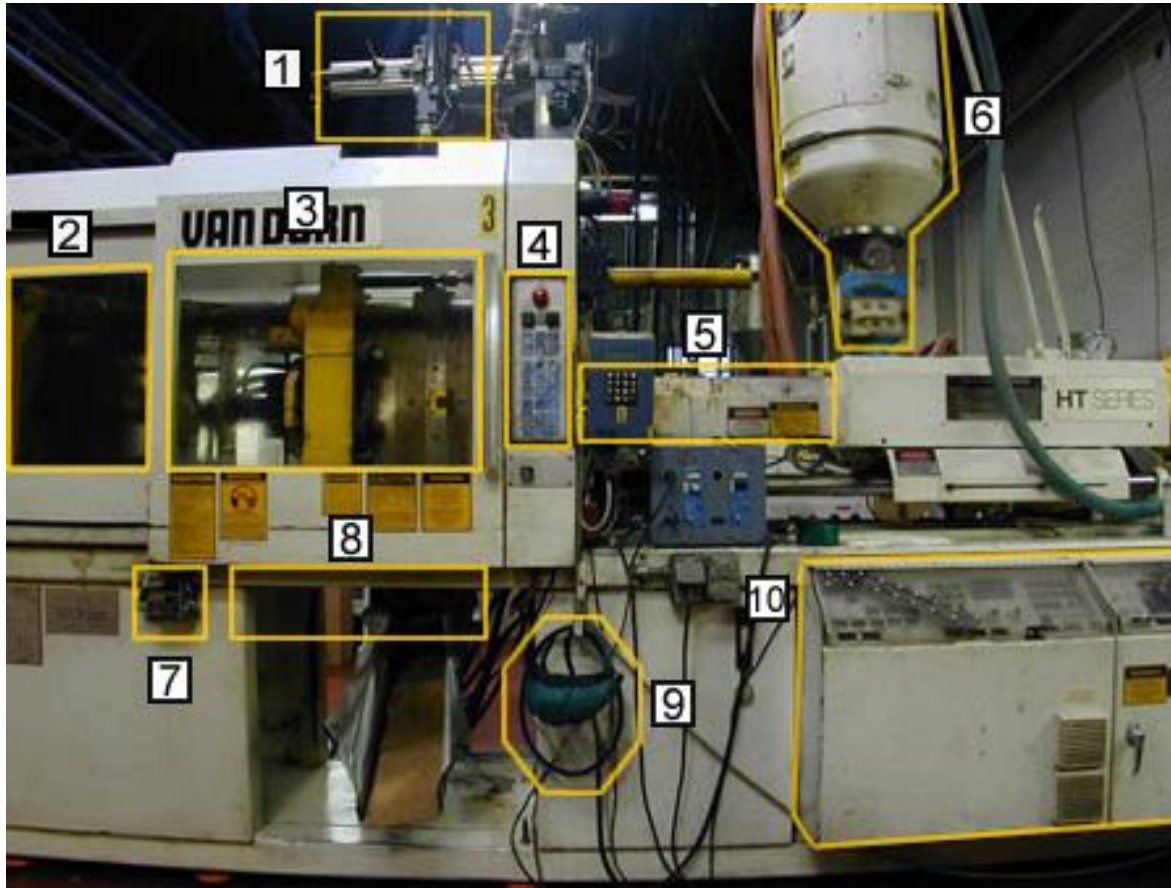

Horizontal Injection Molding

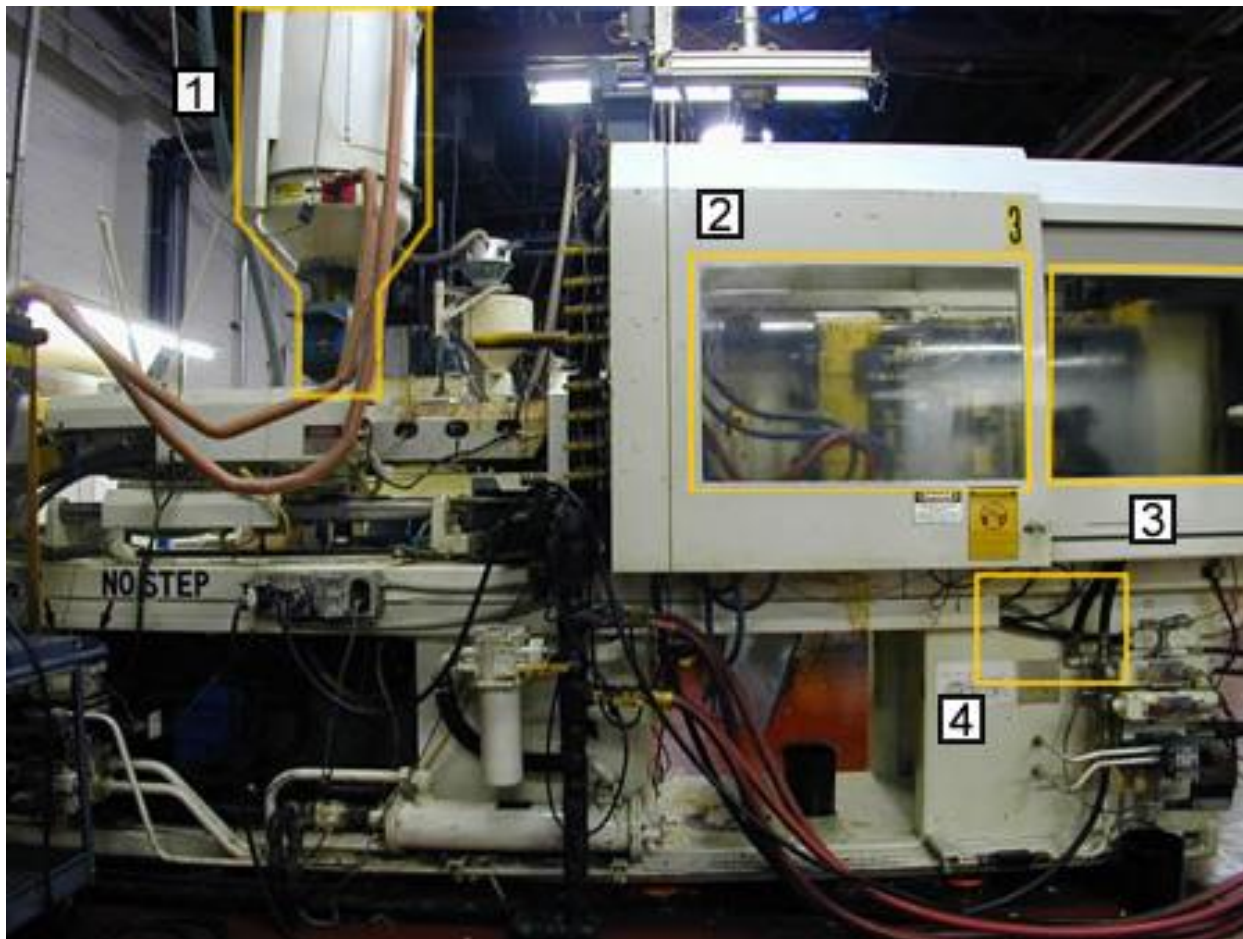

Power Transmission Apparatus

- Hazard—Grab, nip, cut, or strike body parts
- Machines and parts include:
 - Power transmission belts and pulleys, gears, sprockets and chains, shafts, collars, couplings, flywheels, clutches, and other power transmission apparatus
- Action
 - Grabbing, nipping, cutting, flying or falling objects, reciprocating motions, transverse motions, or a combination of these

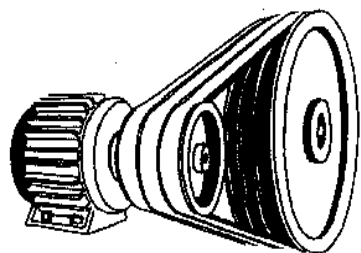

Power Transmission Apparatus Example



Other In Running Nip Points

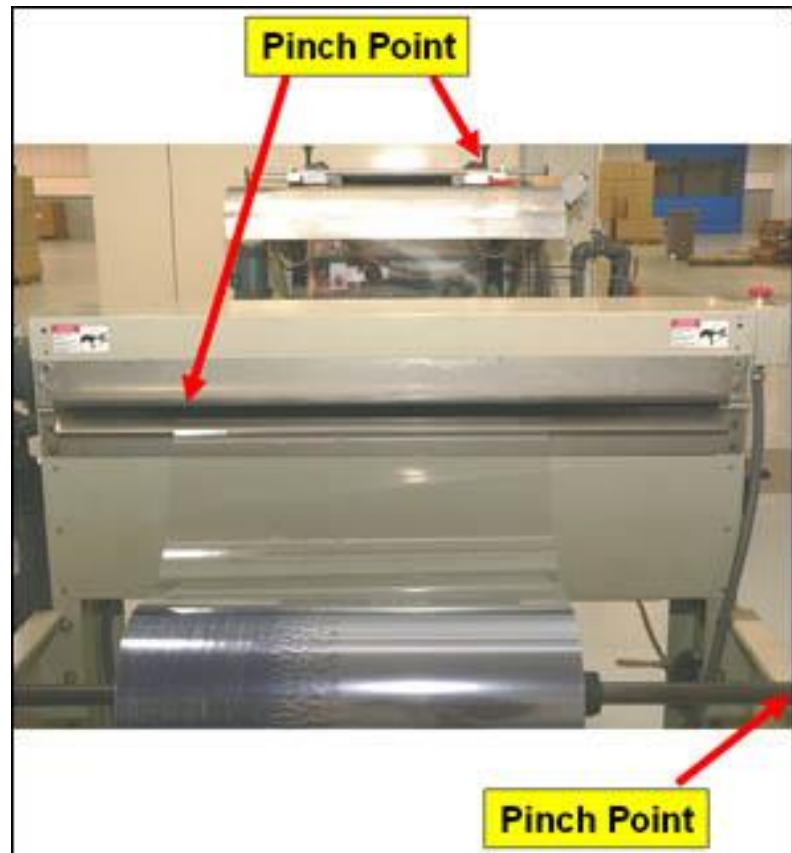

Conveyors

Figure 29 Chain Driven Live Roller Conveyor

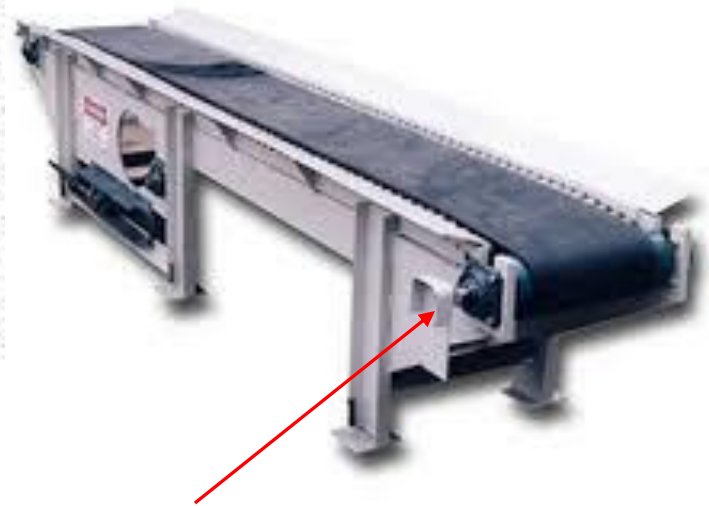
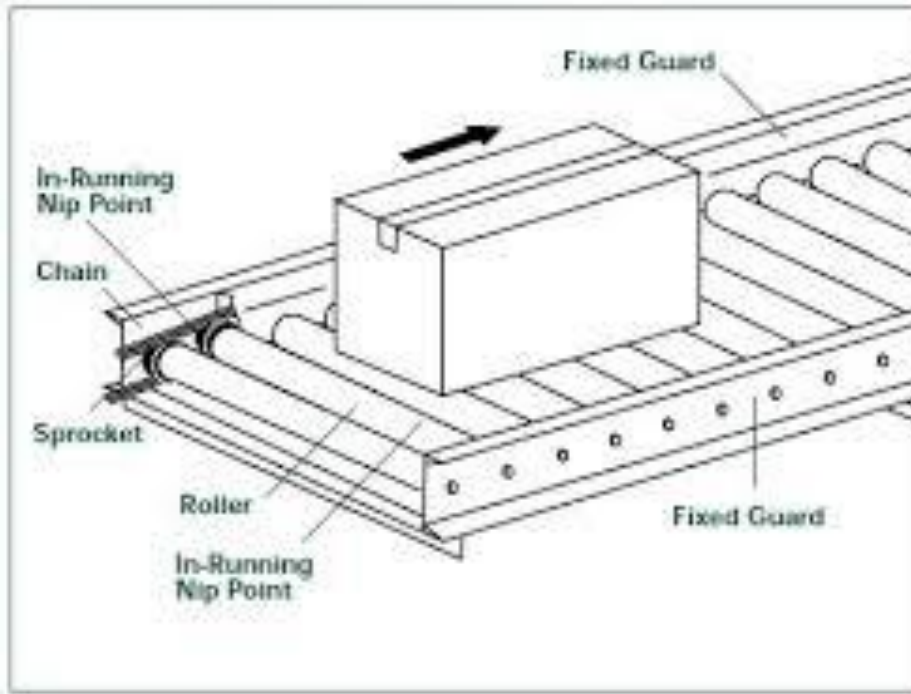

Drill Press Incident



Drill Presses:



Pedestal / Bench Grinders:

- Tongue guard must be no more than 1/4" away from the wheel
- Tool rest must be no more than 1/8" away from the wheel



Safeguard Barriers

Fixed Safeguards

- Permanent part of the machine or apparatus
- Best and simplest guard protection
- Power transmission apparatuses are best protected by fixed guards or barriers that enclose the danger area



Safeguard Barriers

Adjustable or Self-Adjusting Safeguards

- Adjustable to accommodate varying sizes of material placed at the point of operation
- Self-adjusting types move according to the size of the stock



Safeguard Barriers

Interlocked Safeguards

- Interlock device automatically shuts off and quickly stops the machine when the barrier guard is moved to expose the hazard

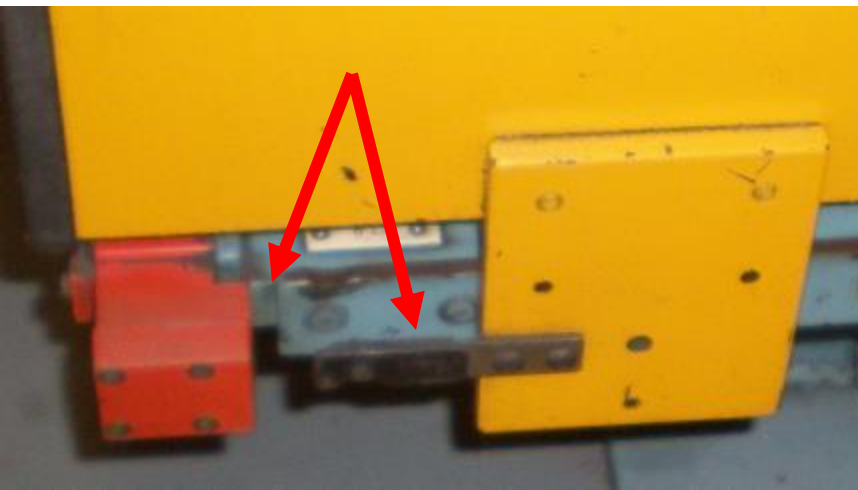

Poll Question

- How frequently do you inspect and document the inspection of equipment safeguards?
 - Monthly
 - Quarterly
 - Annually
 - Periodically
 - UH?!

Classifications of Safeguards

- ~~1. Safeguard barrier ("hard guarding")~~
2. Safeguard device
3. Location and distance
4. Automatic stock feed and ejection method
5. Miscellaneous aids



Safeguard Devices

- Presence-sensing devices automatically shut down equipment
 - Photoelectrical
 - Radio frequency
 - Electromechanical
- Pullbacks or restraints
- Safety trip control
 - Pressure-sensitive body bar
 - Safety tripwire cable

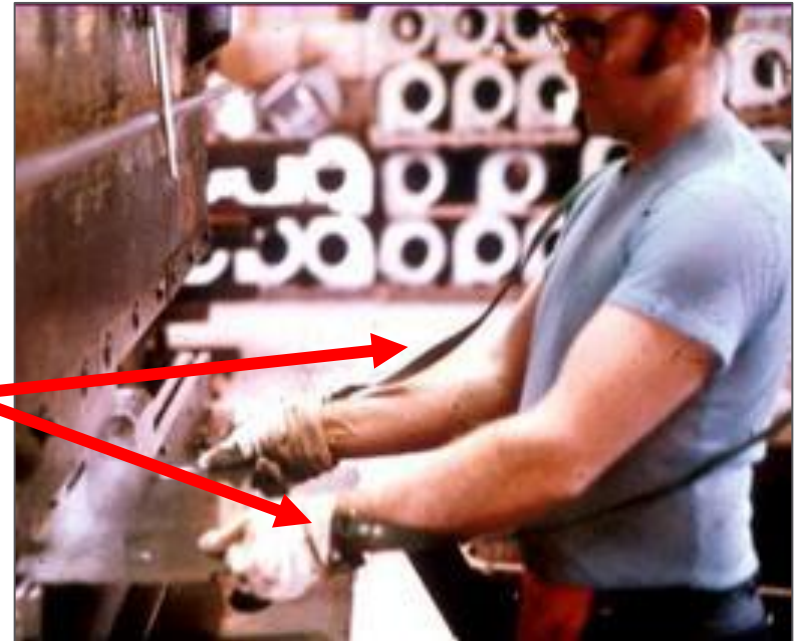

Safeguard Devices

Two-hand devices

- Two-hand controls require constant two-hand pressure during the entire machine cycle
- Two-hand trips activate the machine, then allow hands to be free while machine completes its cycle

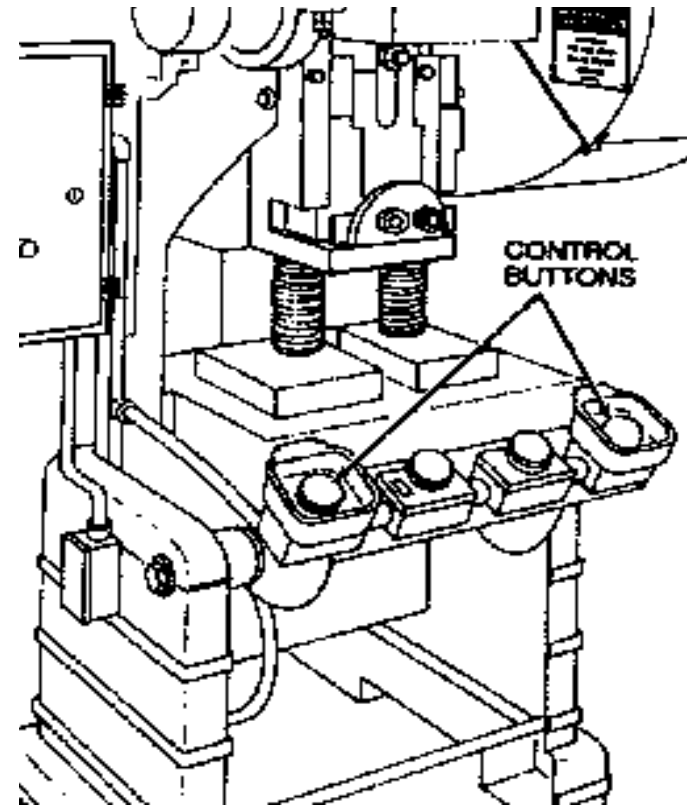

Guarding Pedal



Light Curtain



Location and Distance

- Separates operators from the equipment
- Makes it virtually impossible to contact moving parts
- Limited by the available workspace



Miscellaneous Aids

- Awareness barriers
- Protective shields
- Hand-feeding tools and holding fixtures

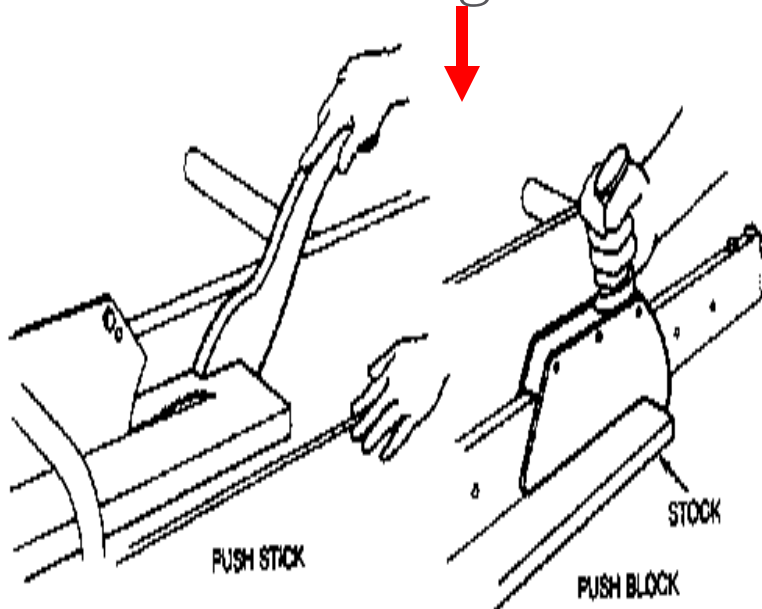

Classifications of Safeguards

1. Safeguard barrier (“hard guarding”)
2. Safeguard device
3. Location and distance
4. Automatic stock feed and ejection method
5. Miscellaneous aids



Going Forward

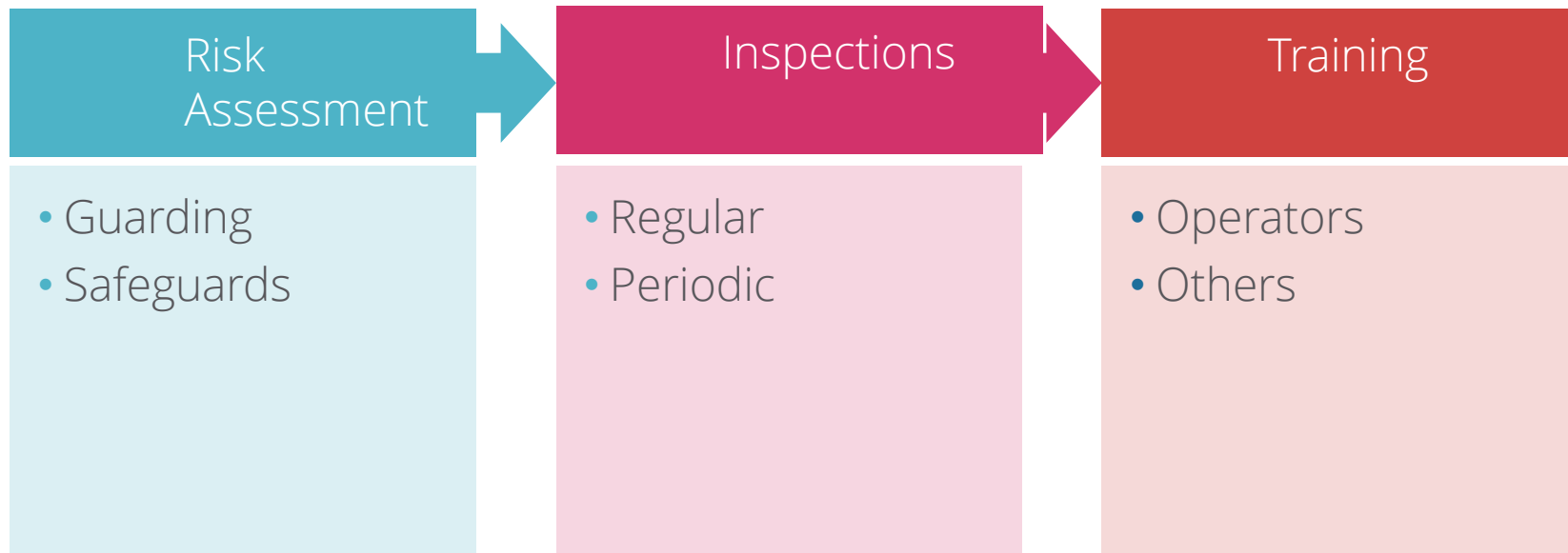

Risk Assessment Machine Safeguards

- ANSI B11.0 (risk assessment)
- ISO 13849-1 and 2
- IEC 60204-1
- Acceptable Risk

Table 2 – Risk level decision matrix

Severity of Injury	Exposure to the Hazard	Avoidance of the Hazard	Risk Level
S1 - Minor	E1 - Low E2 - High	A1 - Likely	NEGLIGIBLE
		A2 - Not Likely	LOW
		A3 - Not Possible	
S2 - Moderate	E1 - Low E2 - High	A1 - Likely	MEDIUM
		A2 - Not Likely	HIGH
		A3 - Not Possible	
S3 - Serious	E1 - Low E2 - High	A1 - Likely	HIGH
		A2 - Not Likely	
		A3 - Not Possible	VERY HIGH

Periodic and Regular Inspections

- Inspect
 - All equipment
 - Auxiliary equipment
 - Safeguards
- Record:
 - Certificate of inspection
 - Date
 - Name & signature of individual who inspected equipment
 - Press number or ID #

Where to Begin Looking

- Vulnerable Neutral Body Parts
 - Mid-thigh to belt buckle
 - Below knee to top of foot
- Where hand interactions occur
- Machine Guard Stickers

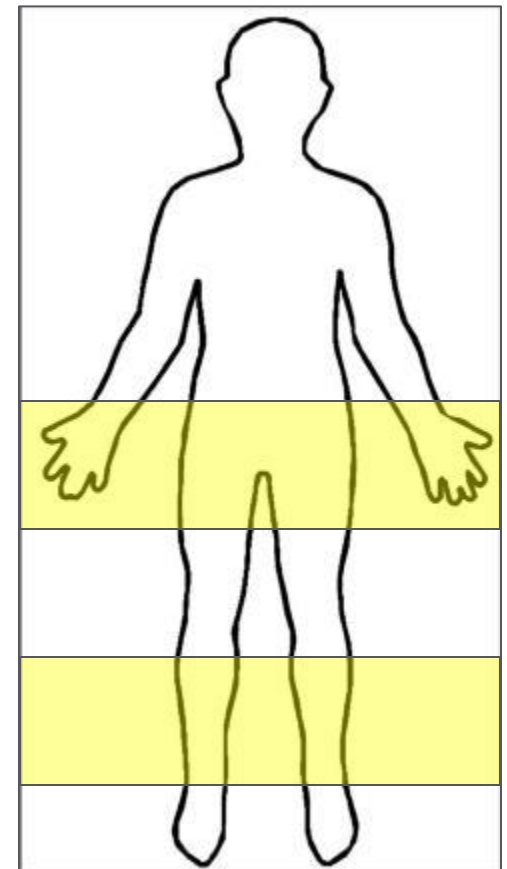

Essential Tools For Evaluating Machine Guards

– OSHA Guard Safety Scale

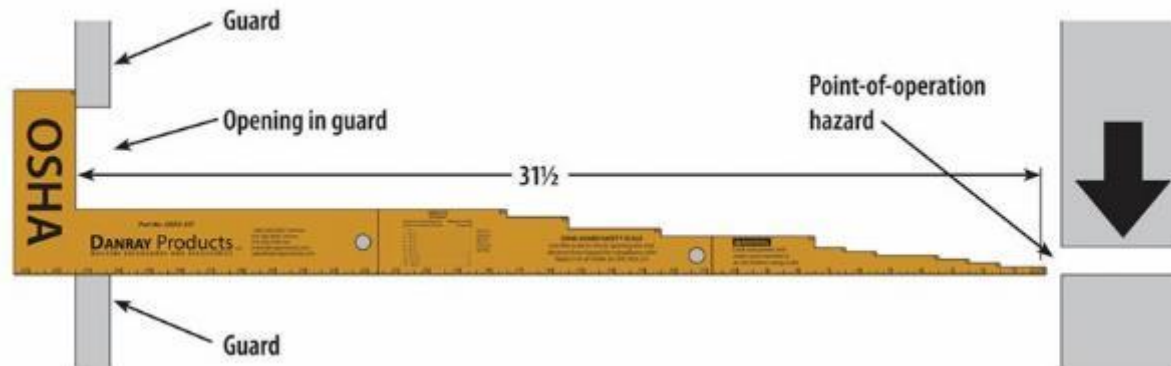

– Bench Grinder Scale



– OSHA Machine Guarding eTool:

<https://www.osha.gov/SLTC/etools/machineguarding/index.html>

Bench Grinder Safety Gauge



Poll Question

- How often are your equipment operators trained on safeguards of equipment? What to look for, how to utilize, etc.?
 - Orientation
 - Annually
 - After an accident
 - Nothing formalized

Training

- The employer is responsible for training the following employees that are involved with power presses
 - Personnel caring for presses
 - Inspecting presses
 - Maintaining
 - Operating

Safeguarding Best Practices

- Operate equipment only when guards are in place and properly adjusted
- NEVER remove or defeat safeguards then using a machine
- Remove guards only when machine is locked / tagged out or energy is isolated in some equally effective manner (interlock devices, cord unplugged and in your control)
- No loose clothing, long hair or jewelry

Safeguarding Best Practices

- Inspect guarding daily
- Make sure warning signs are legible
- Report problems immediately

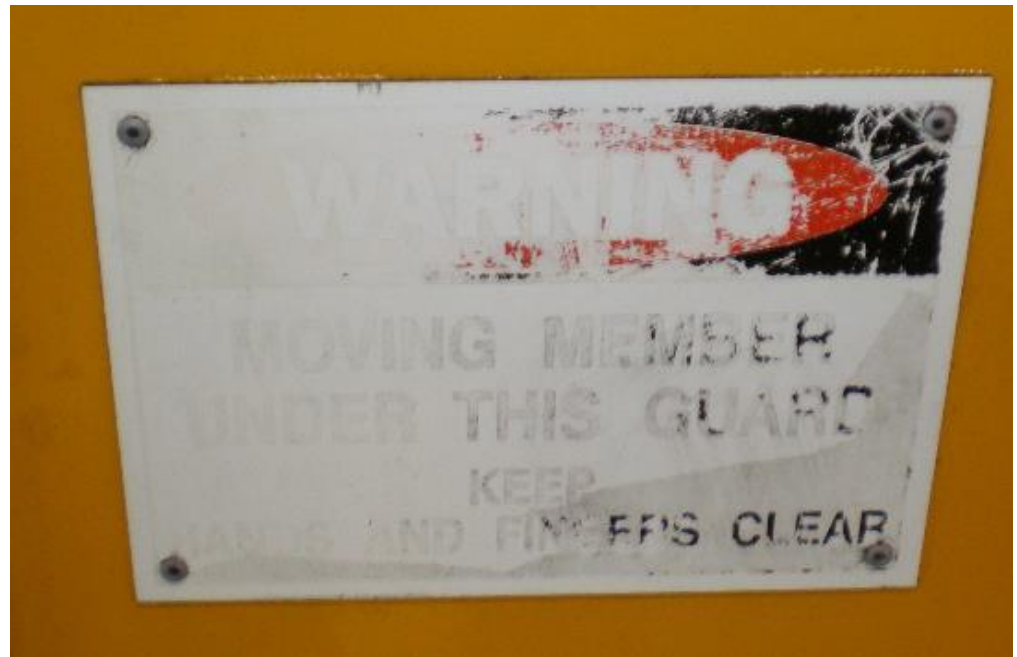

Action Items

- Assess 3 different types of machines in your facility & answer the following questions

1. *Do they have guarding now?*
2. *Is the guarding adequate or inadequate?*
3. *What type of machine guarding solution would best protect your employee?*

Resources:

- OSHA Machine Guarding eTool:

- <https://www.osha.gov/SLTC/etools/machineguarding/index.html>

- OSHA Website

- <https://www.osha.gov/SLTC/machineguarding/>

- OSHA Publication

- OSHA 3170

- <https://www.osha.gov/Publications/OSHA3170/osha3170.html>